

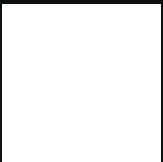

MoMA

Booklet available in English on
Livret disponible en français sur
Folleto disponible en español en



THE STORY

Vincent Willem van Gogh was born in Groot-Zundert, The Netherlands, on March 30, 1853. From a young age, van Gogh was introduced to the world of art by his uncle Vincent and brother Theo, an established art dealer and life-long champion of the artist's work. Living in England, France and Belgium, van Gogh worked as an art curator and a lay preacher, and taught amateur painters before committing fully to his own art.

In just a decade, from 1880 to his death in 1890, van Gogh completed more than 2,000 works, including almost 900 oil paintings, more than 1,100 watercolor paintings, etchings and ink and pencil drawings. His subjects ranged from humble, hardworking miners and farmers, to landscapes, portraits, interiors and still life pieces.

Van Gogh believed he could make his paintings endure only by abandoning "photographic resemblance" and striving for "passionate expression." He was inspired by Japanese prints and the work of his contemporaries such as Paul Gauguin, Henri de Toulouse-Lautrec and Paul Cézanne, and looked to innovations in color theory to inform his own palette—by turns vibrant and brooding—as he developed his own unique heavily impasto painting style.

In a letter to Theo in 1888, he wrote "*I can do nothing about it if my paintings don't sell. The day will come, though, when people will see that they're worth more than the cost of the paint and my subsistence, very meagre in fact, that we put into them.*" Though van Gogh did not live to see his predictions come true, his final exhibitions drew critical acclaim.

"I often think that
the night is more
alive and more richly
colored than the day."

Vincent van Gogh

All works by Vincent van Gogh (Dutch, 1853-1890).

Portrait of Joseph Roulin. Arles, early 1889.
Oil on canvas, 25 3/8 × 21 3/4" (64.4 × 55.2 cm).
The Museum of Modern Art, New York.
Gift of Mr. and Mrs. William A. M. Burden,
Mr. and Mrs. Paul Rosenberg, Nelson A. Rockefeller,
Mr. and Mrs. Armand P. Bartos, The Sidney and Harriet
Janis Collection, Mr. and Mrs. Werner E. Josten, and
Loula D. Lasker Bequest (all by exchange)

The Potato Eaters. April 1885. Lithograph,
composition: 8 7/16 × 12 3/8" (21.5 × 31.4 cm);
sheet: 12 5/16 × 15 3/4" (31.3 × 40 cm). Publisher:
unpublished. Printer: Gestel Printing Works, Nuenen.
Edition: 18 known impressions.
The Museum of Modern Art, New York.
Gift of Mr. and Mrs. A. A. Rosen

Portrait of Dr. Gachet (Man with a Pipe). May 15, 1890.
Etching, plate: 7 1/8 × 5 15/16" (18.1 × 15.1 cm).
The Museum of Modern Art, New York.
Gift of Abby Aldrich Rockefeller

The Olive Trees. Saint Rémy, June-July 1889.
Oil on canvas, 28 5/8 × 36" (72.6 × 91.4 cm).
The Museum of Modern Art, New York.
Mrs. John Hay Whitney Bequest

Traduction à la page 234
Traducciones en la página 234



Self-Portrait with Grey Felt Hat. Paris, 1886/87.
Oil on cardboard, 16 × 12 3/5" (41 × 32 cm).
Amsterdam, Rijksmuseum



L'HISTOIRE

Vincent Willem Van Gogh est né le 30 mars 1853 à Groot-Zundert, aux Pays-Bas. Très jeune, Van Gogh est plongé dans le monde de l'art par son oncle Vincent et son frère Théo, un marchand d'art établi qui a toujours défendu les œuvres de l'artiste. Ayant vécu en Angleterre, en France et en Belgique, Van Gogh a travaillé comme conservateur d'art et prédicateur laïc, et a enseigné à des peintres amateurs avant de se consacrer pleinement à son art.

En une seule décennie, de 1880 jusqu'à sa mort en 1890, Van Gogh réalise plus de 2 000 œuvres, dont près de 900 peintures à l'huile et plus de 1 100 aquarelles, gravures à l'eau-forte et dessins à l'encre et au crayon. Ses sujets vont d'humbles mineurs et fermiers à des paysages, portraits, intérieurs et natures mortes.



Van Gogh croit qu'il ne peut faire perdurer ses peintures qu'en abandonnant la « ressemblance photographique » et en s'efforçant d'atteindre une « expression passionnée ». Il s'inspire des estampes japonaises et des œuvres de ses contemporains tels que Paul Gauguin, Henri de Toulouse-Lautrec et Paul Cézanne, et s'appuie sur les innovations de la théorie des couleurs pour créer sa propre palette — tantôt éclatante, tantôt sombre — tout en développant son style unique de peinture fortement empâtée.

Dans une lettre adressée à Théo en 1888, il écrit : « Je n'y puis rien que mes tableaux ne se vendent pas. Le jour viendra cependant où l'on verra que cela vaut plus que le prix de la couleur et de ma vie en somme très maigre, que nous y mettons. » Bien que Van Gogh n'ait pas été témoin de la réalisation de ses prédictions, ses dernières expositions ont été saluées par la critique.



« Souvent, il me semble que la nuit est encore plus richement colorée que le jour. »

- Vincent van Gogh

LA HISTORIA

Vincent Willem van Gogh nació en Groot-Zundert (Países Bajos) el 30 de marzo de 1853. Desde temprana edad, Van Gogh conoció el mundo del arte de la mano de su tío Vincent y su hermano Theo, un comerciante de arte establecido que promovió el trabajo del artista durante toda su vida. Residiendo en Inglaterra, Francia y Bélgica en distintas épocas, Van Gogh trabajó como curador de arte, predicador laico y maestro de pintores aficionados antes de dedicarse por completo a sus propias obras.

En solo una década, de 1880 hasta su muerte en 1890, Van Gogh produjo más de 2000 obras, incluidas casi 900 pinturas al óleo, más de 1100 acuarelas, grabados y dibujos a tinta y a lápiz. Sus creaciones abordan una extensa gama de temas, desde esmerados mineros y granjeros hasta paisajes, escenas interiores e imágenes de naturaleza muerta.

Van Gogh estaba convencido de que la única manera de hacer que sus pinturas perduraran era abandonar la "similitud fotográfica" y aspirar a la "expresión apasionada". Entre sus fuentes de inspiración estaban las estampas japonesas y las obras de contemporáneos suyos como Paul Gauguin, Henri de Toulouse-Lautrec y Paul Cézanne. Vincent, además, buscó innovaciones en la teoría del color para enriquecer sus paletas —en ocasiones vibrantes, y otras veces sombrías— a medida que desarrollaba su propio estilo de pintura, caracterizado por una técnica *impasto* bastante marcada.

En una carta de 1888 dirigida a Theo, escribió: "No hay nada que pueda hacer si mis pinturas no se venden. Sin embargo, llegará un día en el que las personas verán que valen más que los costos de la pintura y mi subsistencia, bastante precaria de hecho, que les hemos dedicado". Aunque Van Gogh no vivió para ver sus predicciones hacerse realidad, sus últimas exposiciones recibieron la aclamación de la crítica.

" Con frecuencia pienso que la noche tiene más vida y está más llena de color que el día "

- Vincent van Gogh

THE STARRY NIGHT

In May 1889, after a period of deteriorating health, van Gogh admitted himself to the Saint Paul-de-Mausole asylum at Saint-Rémy-de-Provence near Arles, France, where he was treated for epilepsy. As part of his therapy, he was encouraged to continue painting. The serene gardens and landscapes in Saint-Rémy allowed him to recover and focus fully on his art. Within a year, he had completed at least 150 works, including *The Starry Night*.

In a letter to his brother, the artist wrote, "*The sight of the stars always makes me dream.*" Like many of van Gogh's paintings, this timeless artwork, with its swirling blue and yellow brush strokes, imbues night and nature with an emotional language beyond their actual appearances.

Acquired by The Museum of Modern Art (MoMA) in 1941, it was the first artwork by van Gogh to enter a New York museum collection, and it continues to be a visitor favorite in the Museum's galleries. Now you can reimagine and create your own 3D version, thanks to this exceptional collaboration between MoMA, fan designer Truman Cheng and LEGO® Ideas designers.

THE WORLD'S MUSEUM FOR MODERN AND CONTEMPORARY ART

The Museum of Modern Art in New York City brings creativity and inspiration to people all over the world. Founded in 1929 by three women, MoMA was the first museum dedicated to new art—from paintings and drawings to film, design and performance. This bold, experimental vision continues by sharing the most thought-provoking and resonant works today.

Cypress trees were a common motif in van Gogh's later paintings. A symbol of death in Greek culture, they connect heaven and earth in *The Starry Night*.

Les cyprès sont un motif courant dans les tableaux plus tardifs de Van Gogh. Symboles de la mort dans la culture grecque, les cyprès relient le ciel et la terre dans *La nuit étoilée*.

Los cipreses son un tema recurrente en las pinturas de Van Gogh más tardías. Un símbolo de muerte en la cultura griega, conectan el cielo y la tierra en *La noche estrellada*.

The Starry Night. Saint-Rémy, June 1889. Oil on canvas, 29 × 36 1/4" (73.7 × 92.1 cm). The Museum of Modern Art, New York. Acquired through the Lillie P. Bliss Bequest (by exchange)

Traduction à la page 10
Traducciones en la página 10



Size comparison
Comparaison des tailles
Comparación en tamaño.





Photo / Fotografía: Brett Beyer

MoMA

Because he couldn't paint at night, van Gogh painted *The Starry Night* from memory and reimagined the landscape and night sky.

Comme il ne pouvait pas peindre la nuit, Van Gogh a peint *La nuit étoilée* de mémoire et a réinventé le paysage et le ciel nocturne.

Debido a que no podía trabajar en sus creaciones de noche, Van Gogh pintó *La noche estrellada* de memoria, reimaginando el paisaje y el cielo nocturno.

LA NUIT ÉTOILÉE

En mai 1889, après une longue détérioration de sa santé, Van Gogh se fait interner à l'asile Saint-Paul-de-Mausole à Saint-Rémy-de-Provence, près d'Arles, en France, où il est traité pour des problèmes d'épilepsie. Dans le cadre de sa thérapie, on l'encourage à continuer à peindre. Les jardins et paysages sereins de Saint-Rémy lui permettent de se rétablir et de se concentrer pleinement sur son art. En un an, il achève au moins 150 œuvres, dont *La nuit étoilée*.

Dans une lettre adressée à son frère, l'artiste écrit : « Toujours la vue des étoiles me fait rêver. » Comme de nombreux tableaux de Van Gogh, cette œuvre intemporelle, avec ses coups de pinceau bleu et jaune tourbillonnants, imprègne la nuit et la nature d'un langage émotionnel qui va au-delà de leurs apparences réelles.

Acquis par le Museum of Modern Art (MoMA) en 1941, ce tableau est la première œuvre de Van Gogh à entrer dans la collection d'un musée new-yorkais, et reste l'une des œuvres préférées des visiteurs dans les galeries du musée. Vous pouvez désormais imaginer et créer votre propre version en 3D, grâce à cette collaboration exceptionnelle entre le MoMA, le concepteur amateur Truman Cheng et les concepteurs de LEGO® Ideas.

LE MUSÉE MONDIAL D'ART MODERNE ET CONTEMPORAIN

The Museum of Modern Art de New York apporte créativité et inspiration aux gens du monde entier. Fondé en 1929 par trois femmes, le MoMA est le premier musée consacré à l'art moderne, allant des peintures et des dessins aux films, au design et aux performances. Cette vision audacieuse et expérimentale se perpétue par le partage des œuvres les plus percutantes et marquantes d'aujourd'hui.

LA NOCHE ESTRELLADA

En mayo de 1889, después de un período en el que su estado físico se había estado deteriorando, Van Gogh se internó en el manicomio de Saint-Paul en Saint-Rémy-de-Provence, cerca de Arlés (Francia), donde recibió tratamiento para la epilepsia. Como parte de su terapia, se le animó a seguir pintando. Los serenos jardines y paisajes de Saint-Rémy le permitieron recuperarse y enfocarse de lleno en su arte. Solo en el año que transcurrió a partir de su ingreso, produjo un mínimo de 150 obras, incluida *La noche estrellada*.

En una carta dirigida a su hermano, el artista escribió: "*Ver las estrellas siempre me hace soñar*". Como muchas de las pinturas de Van Gogh, esta intemporal obra de arte con ondulantes pinceladas en azul y amarillo impregna la noche y la naturaleza de un lenguaje emocional más allá de su apariencia real.

Adquirida por el Museo de Arte Moderno (MoMA) en 1941, fue la primera obra creada por Van Gogh en ser incorporada a la colección de un museo de Nueva York (EE. UU.), y sigue siendo una de las piezas favoritas de quienes visitan las galerías del museo. Ahora puedes reimaginar y crear tu propia versión en 3D gracias a esta excepcional colaboración entre el MoMA, el fan diseñador Truman Cheng y los diseñadores de LEGO® Ideas.

UN MUSEO DE ARTE MODERNO Y CONTEMPORÁNEO PARA EL MUNDO

El Museo de Arte Moderno de la ciudad de Nueva York lleva creatividad e inspiración a personas de todo el mundo. Fundado en 1929 por tres mujeres, el MoMA fue el primer museo dedicado al arte nuevo, desde pinturas y dibujos hasta producciones de cine, diseño y *performance*. El hecho de que comparta las obras más reflexivas y resonantes de nuestros días es una clara muestra de que esta visión audaz y experimental continúa hasta hoy.

MEET THE FAN DESIGNER

Truman Cheng (LEGO® Ideas name legotruman) from Hong Kong is a PhD student in medical robotics. How does that relate to recreating world-famous art with LEGO bricks?

"Robotics is just one form of creative problem-solving that I love. I also love art and drawing new fantasy/sci-fi characters from my imagination. LEGO is very special to me because it is a unique synthesis of artistic expression and puzzle-solving."

"Van Gogh's work has always fascinated me, and *The Starry Night* is one of his most iconic works. I have always wanted to make a LEGO version of it but couldn't think of a good execution style. One day, I was playing with LEGO elements and discovered that stacking them together in random intervals looks a lot like van Gogh's iconic brush strokes!"

"So, I based my model on the original painting and took some creative liberties with the 3D aspect of the design. It was a good brain teaser to find the best techniques and LEGO parts to capture the look of the original painting. Keeping all parts of the painting on the right scale was really challenging, so I just kept building and modifying. Once the model launched on the LEGO Ideas platform, it gathered 10,000 supporters in just three weeks! Thank you so much to everyone who voted!"



"I think the van Gogh minifigure working on his painting while looking upon the LEGO *Starry Night* model is a really fun detail!"



The Meet Vincent van Gogh Experience
by the Van Gogh Museum Amsterdam
L'exposition Rencontrez Vincent van Gogh
du musée Van Gogh d'Amsterdam
La experiencia Meet Vincent van Gogh
del Museo Van Gogh de Amsterdam



RENCONTRE AVEC LE CONCEPTEUR AMATEUR

Originaire de Hong Kong, Truman Cheng (pseudonyme LEGO® Ideas : legotruman), est un doctorant en robotique médicale. En quoi cela se rattache-t-il à la reproduction d'œuvres d'art de renommée mondiale avec des briques LEGO ?

« La robotique n'est qu'une forme créative de résolution de problèmes que j'adore. J'aime aussi l'art et la création de nouveaux personnages de fantaisie et de science-fiction issus de mon imagination. LEGO est très spécial pour moi, car c'est une synthèse unique de l'expression artistique et de la résolution de casse-têtes. »

« Le travail de Van Gogh m'a toujours fasciné, et *La nuit étoilée* est l'une de ses œuvres les plus emblématiques. J'ai toujours voulu en faire une version LEGO, mais je n'arrivais pas à trouver un bon style d'exécution. Un jour, alors que je jouais avec des éléments LEGO, j'ai découvert qu'en les empilant à intervalles aléatoires, ils ressemblaient beaucoup aux coups de pinceau emblématiques de Van Gogh ! »

« J'ai donc basé mon modèle sur la peinture originale et j'ai pris quelques libertés créatives avec l'aspect 3D de la conception. C'était un bon exercice de trouver les meilleures techniques et pièces LEGO pour reproduire l'aspect de la peinture originale. Garder toutes les parties de la peinture à la bonne échelle était un vrai défi, et j'ai dû construire en modifiant à maintes reprises. Une fois lancé sur la plateforme LEGO Ideas, le modèle a récolté 10 000 soutiens en seulement trois semaines ! Merci beaucoup à tous ceux qui ont voté ! »

« Je crois que la figurine de Van Gogh qui travaille sur son tableau tout en regardant le modèle LEGO de *La nuit étoilée* est un détail vraiment charmant ! »

CONOCE AL FAN DISEÑADOR

Truman Cheng (legotruman en LEGO® Ideas), residente de Hong Kong, estudia un doctorado en robótica médica. ¿Qué relación tiene eso con recrear obras de arte de fama mundial utilizando bricks LEGO?

“La robótica es solo una forma de resolver problemas con creatividad que me encanta. También me gusta el arte y dibujar nuevos personajes de fantasía/ciencia ficción que imagino. LEGO es muy especial para mí porque representa una síntesis única de la expresión artística y la solución de enigmas”.

“El trabajo de Van Gogh siempre me ha fascinado, y *La noche estrellada* es una de sus obras más icónicas. Siempre había querido hacer una versión LEGO, pero no se me ocurría una buena técnica de ejecución. Un día, mientras jugaba con piezas LEGO, descubrí que apilarlas a intervalos al azar, ¡produce algo que se parece mucho a las icónicas pinceladas de Van Gogh!”.

“Entonces, decidí basar mi modelo en la pintura original, tomando algunas libertades creativas con el aspecto en 3D del diseño. Me divertí mucho buscando las mejores técnicas y piezas LEGO para capturar el aspecto de la pintura original, aunque no fue fácil. Además, mantener todas las partes de la pintura en la escala correcta fue todo un desafío, así que solo seguí construyendo y haciendo modificaciones. Una vez que el modelo se lanzó en la plataforma LEGO Ideas, reunió 10.000 simpatizantes en solo tres semanas. ¡Agradezco mucho a quienes votaron!”.

“ ¡Creo que la minifigura de Van Gogh trabajando en su pintura mientras mira el modelo de *La noche estrellada* en formato LEGO es un detalle muy divertido! ”.

THE LEGO® ARTISTS

"This set re-imagines the original painting in a 3D scene, with strong emphasis on the artist's iconic brush strokes and color choice. A 3D painting is not normally something we would release as a model, but it was a fun challenge. I was amazed by all the details Truman captured from the original painting. I wanted to make sure we created a great building experience as well as a work of art. We worked closely with MoMA, experimented with lots of different building techniques and angles, and I kept going back to every LEGO® element to get the colors and placement right and, hopefully, do van Gogh's beautiful brush work justice!"

- Søren Gehlert Dyrhøj, LEGO® Model Design Master

"This set is truly made for every art lover, especially for van Gogh fans. And we couldn't have done it without MoMA. The final model is so impressive, it shows depth and layers that mimic the techniques used in the actual painting. The most challenging part was designing *The Starry Night* painting on a tiny LEGO brick canvas! I incorporated van Gogh's brush stroke techniques in all the decorations. I love the little Vincent van Gogh minifigure, his miniature canvas and palette. You can place the artist inside the painting or display him as a standalone minifigure!"

- Niken Ayumurti Hartomo, LEGO® Senior Graphic Designer





LES ARTISTES LEGO®

« Cet ensemble réinvente la peinture originale dans une scène en 3D, en mettant l'accent sur les coups de pinceau et les choix de couleurs emblématiques de l'artiste. Une peinture en 3D n'est normalement pas quelque chose que nous présenterions comme modèle, mais c'était un défi amusant. J'ai été impressionné par tous les détails de la peinture originale que Truman a réussi à reproduire. Je voulais m'assurer que nous créions une expérience de construction formidable en plus d'une œuvre d'art. Nous avons travaillé en étroite collaboration avec le MoMA et expérimenté plusieurs techniques de construction et angles différents. J'ai revisité chaque élément LEGO® plusieurs fois pour m'assurer que les couleurs et l'agencement étaient parfaits. J'espère que le résultat final rend honneur au magnifique travail au pinceau de Van Gogh ! »

- Søren Gehlert Dyrhøj, maître de conception de modèles LEGO®

« Cet ensemble est fait pour tous les amateurs d'art, en particulier pour les admirateurs de Van Gogh. Nous n'aurions pas pu le faire sans le MoMA. Le modèle final est remarquable : il présente une profondeur et des couches qui imitent les techniques utilisées dans la peinture réelle. La partie la plus difficile a été de concevoir la peinture *La nuit étoilée* sur une minuscule toile en briques LEGO ! J'ai incorporé les techniques de coup de pinceau de Van Gogh dans toutes les décorations. J'adore la petite figurine de Vincent Van Gogh avec sa toile et sa palette miniatures. Vous pouvez placer l'artiste à l'intérieur du tableau ou l'exposer comme une figurine individuelle ! »

- Niken Ayumurti Hartomo, graphiste principale LEGO®

LOS ARTISTAS DE LEGO®

"Este set reimagina la pintura original en una escena en 3D, con un gran énfasis en las icónicas pinceladas y elecciones de color del artista. Una pintura en 3D no es algo que normalmente lanzaríamos al mercado como un modelo, pero representó un divertido desafío. Estoy asombrado con todos los detalles de la pintura original que Truman logró capturar. Mi intención era asegurarme de que creáramos una fantástica experiencia de construcción y, al mismo tiempo, una obra de arte. Trabajamos de cerca con el MoMA, experimentamos con muchas técnicas de construcción y ángulos diferentes. Seguí repasando todas las piezas LEGO® para encontrar los colores y la ubicación correctos, ¡con la esperanza de hacer justicia a la hermosa técnica de Van Gogh con el pincel!"

- Søren Gehlert Dyrhøj, maestro de diseño de modelos LEGO®

"Este set está hecho para los apreciadores del arte, especialmente para los fans de Van Gogh. Además, no podríamos haberlo logrado sin el MoMA. El modelo final es muy impresionante, muestra profundidad y capas que imitan a la perfección las técnicas utilizadas en la pintura de verdad. ¡La parte más desafiante fue recrear la pintura *La noche estrellada* en un pequeño lienzo de bricks LEGO! Incorporé las técnicas de las pinceladas de Van Gogh en todas las decoraciones. Me encanta la pequeña minifigura de Vincent van Gogh, con su lienzo y su paleta en miniatura. Puedes colocar al artista adentro de la pintura, ¡o exponerlo como una minifigura independiente!"

- Niken Ayumurti Hartomo, diseñadora gráfica sénior de LEGO®

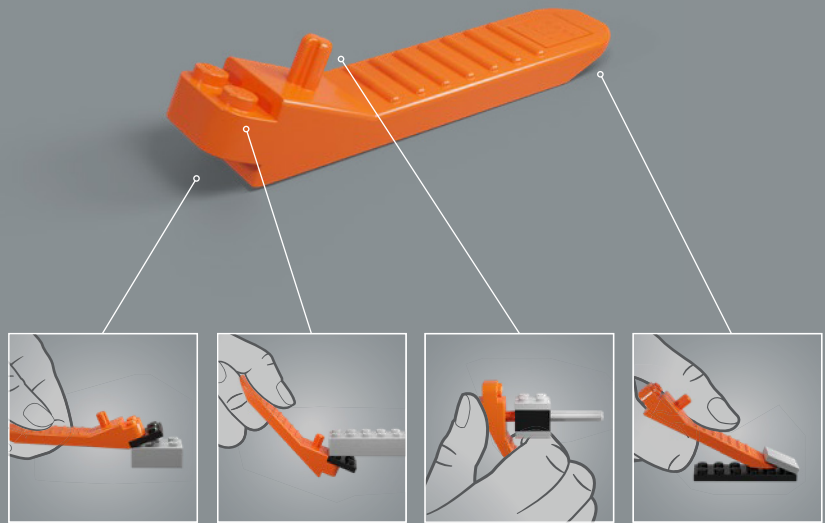

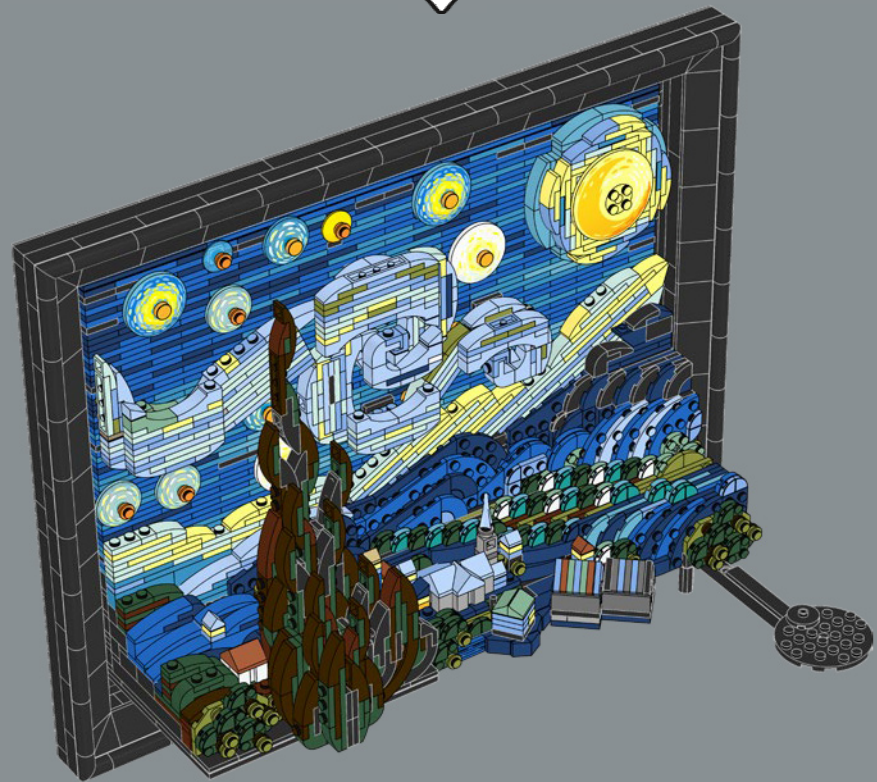
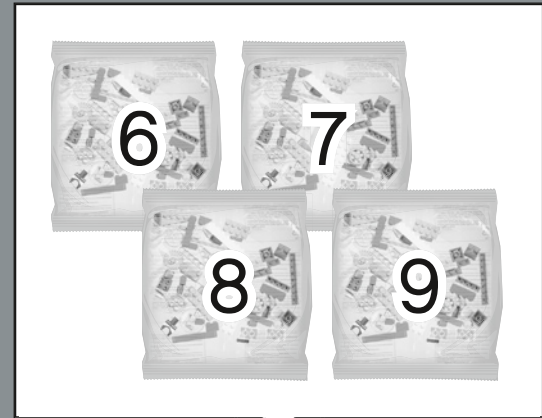
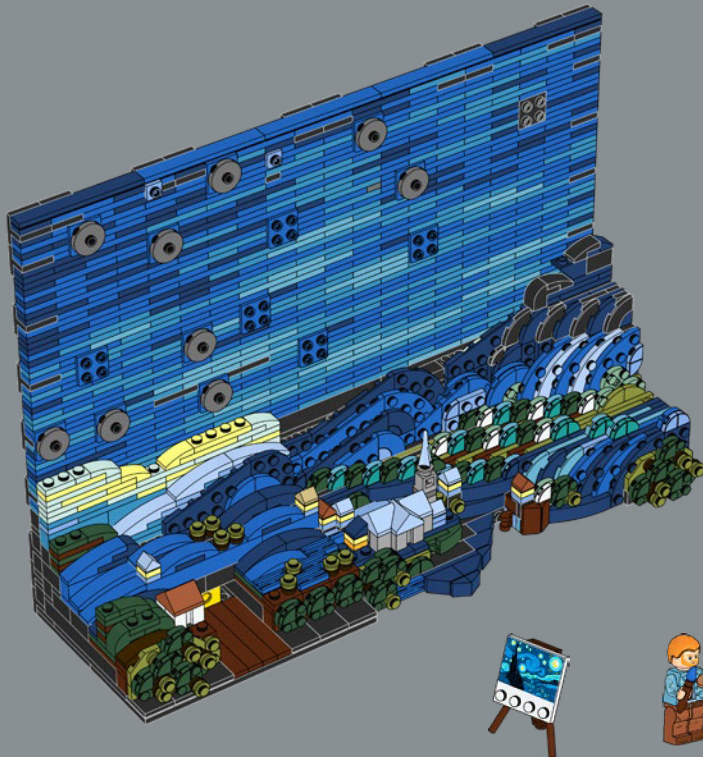
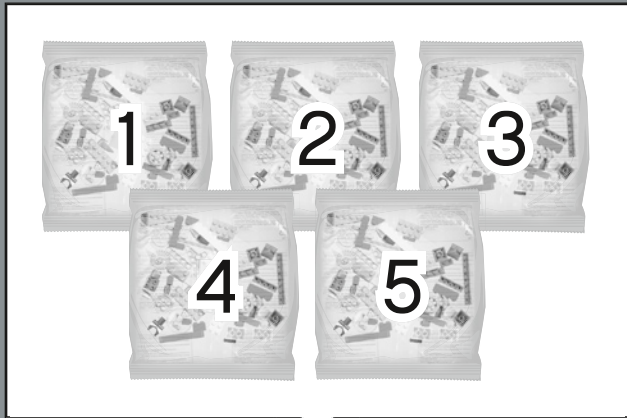

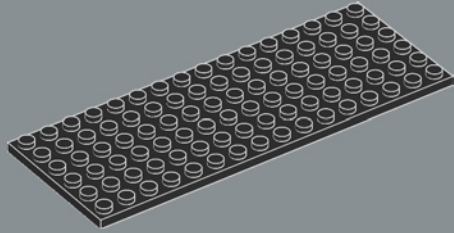
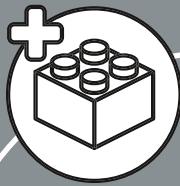

2x

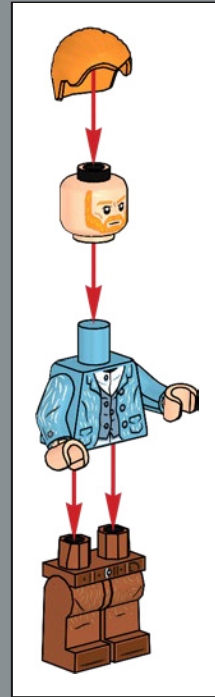

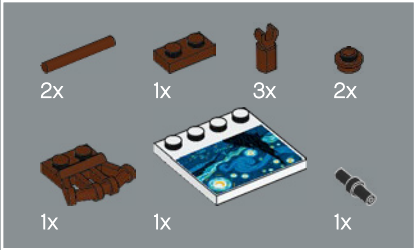
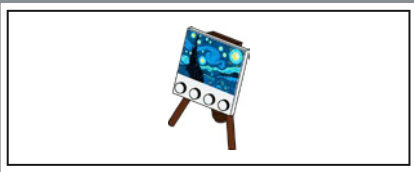

1

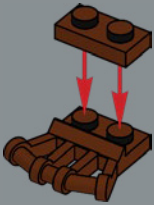

2

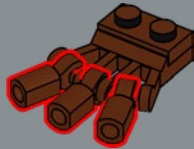

3

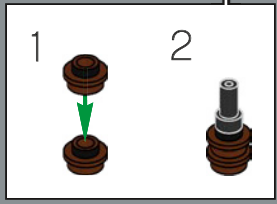
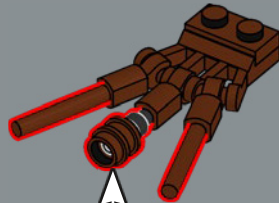

4



5



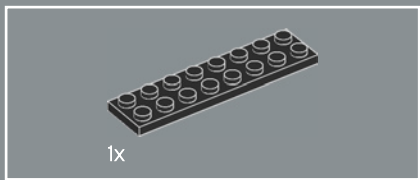

1

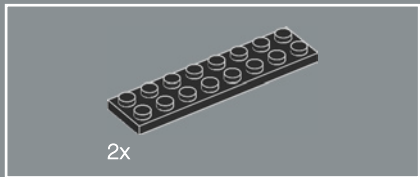
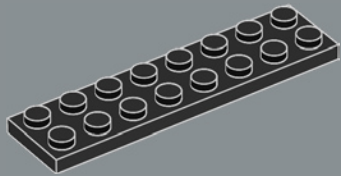

2

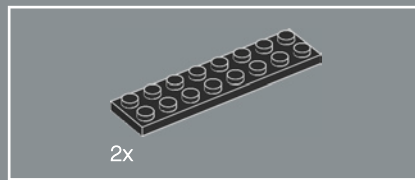
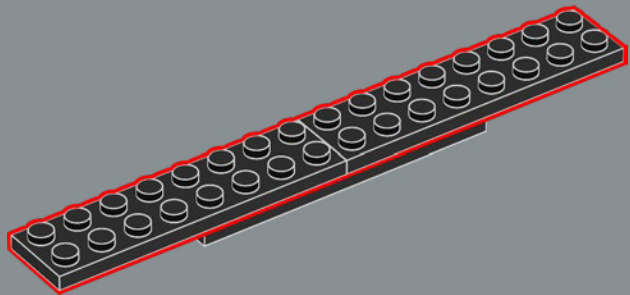

3

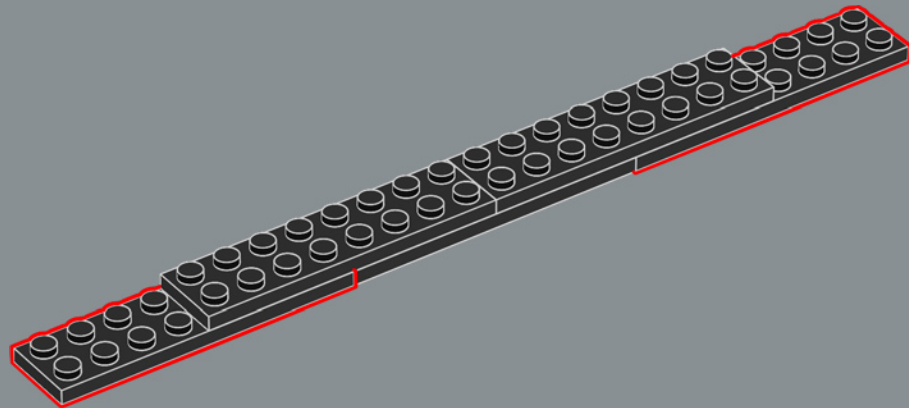

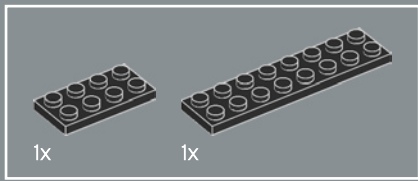

4

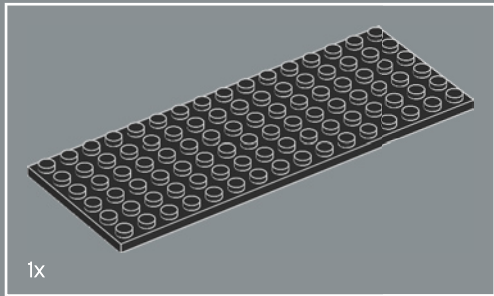
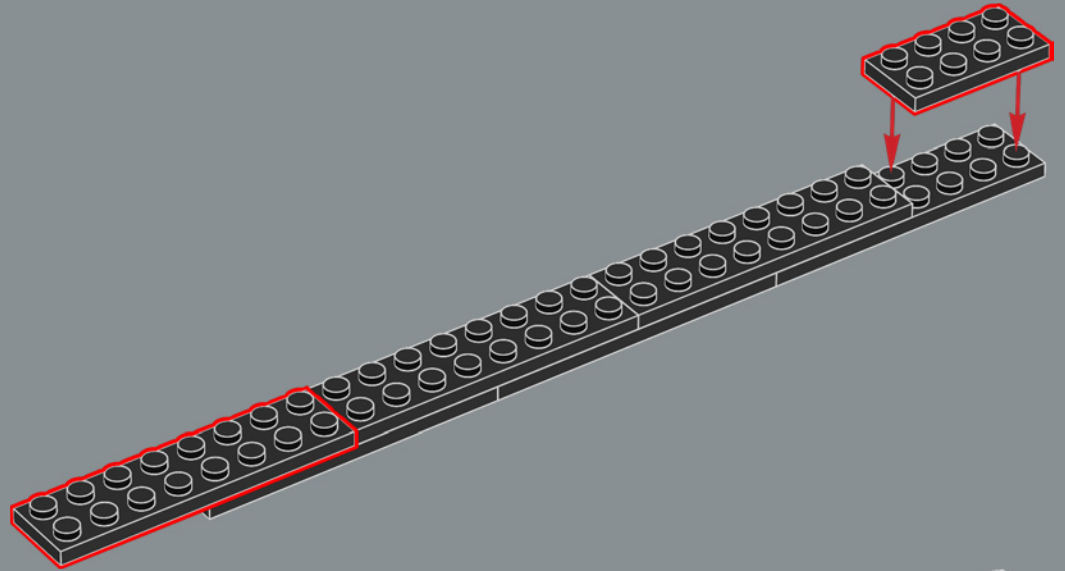

5

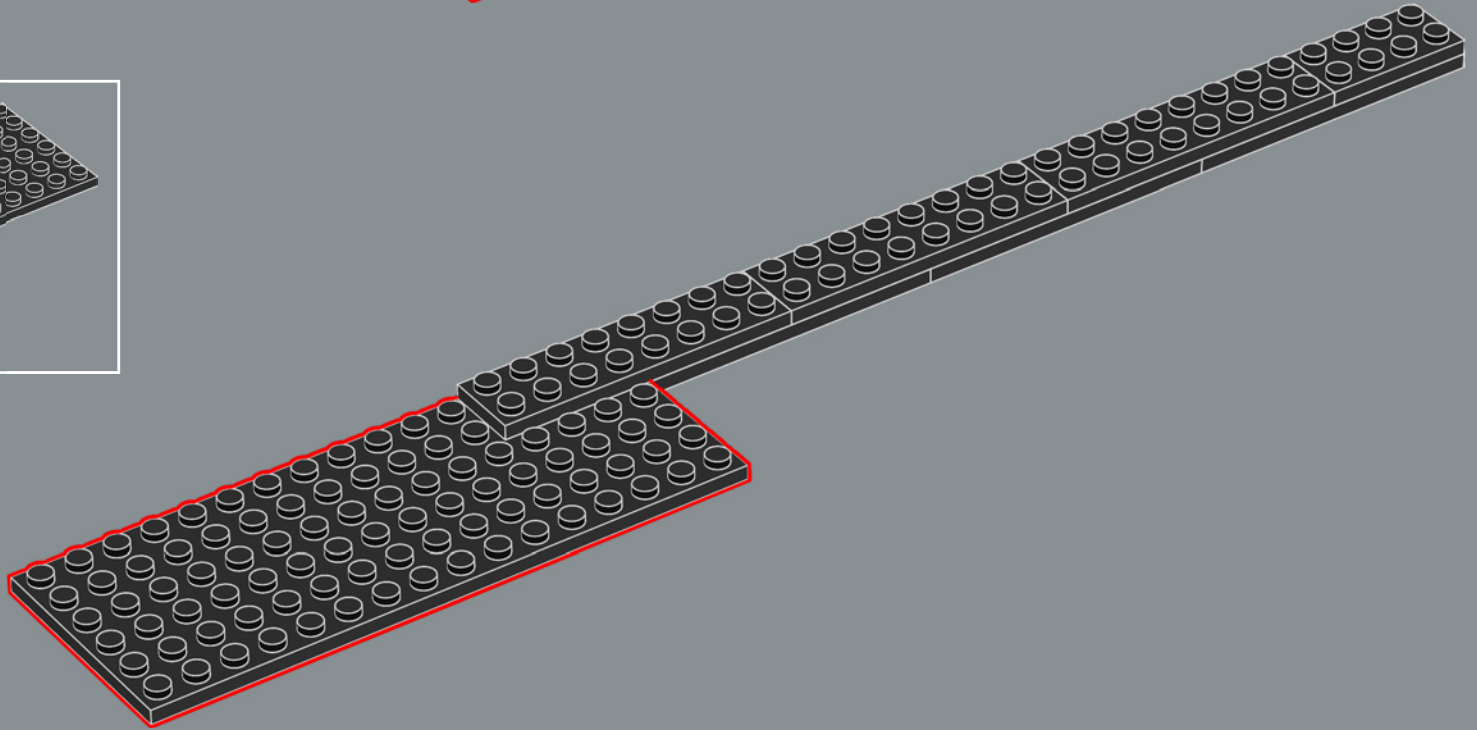

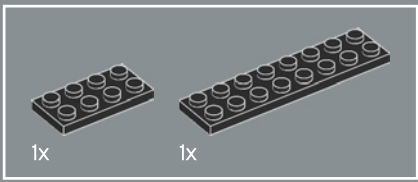

6

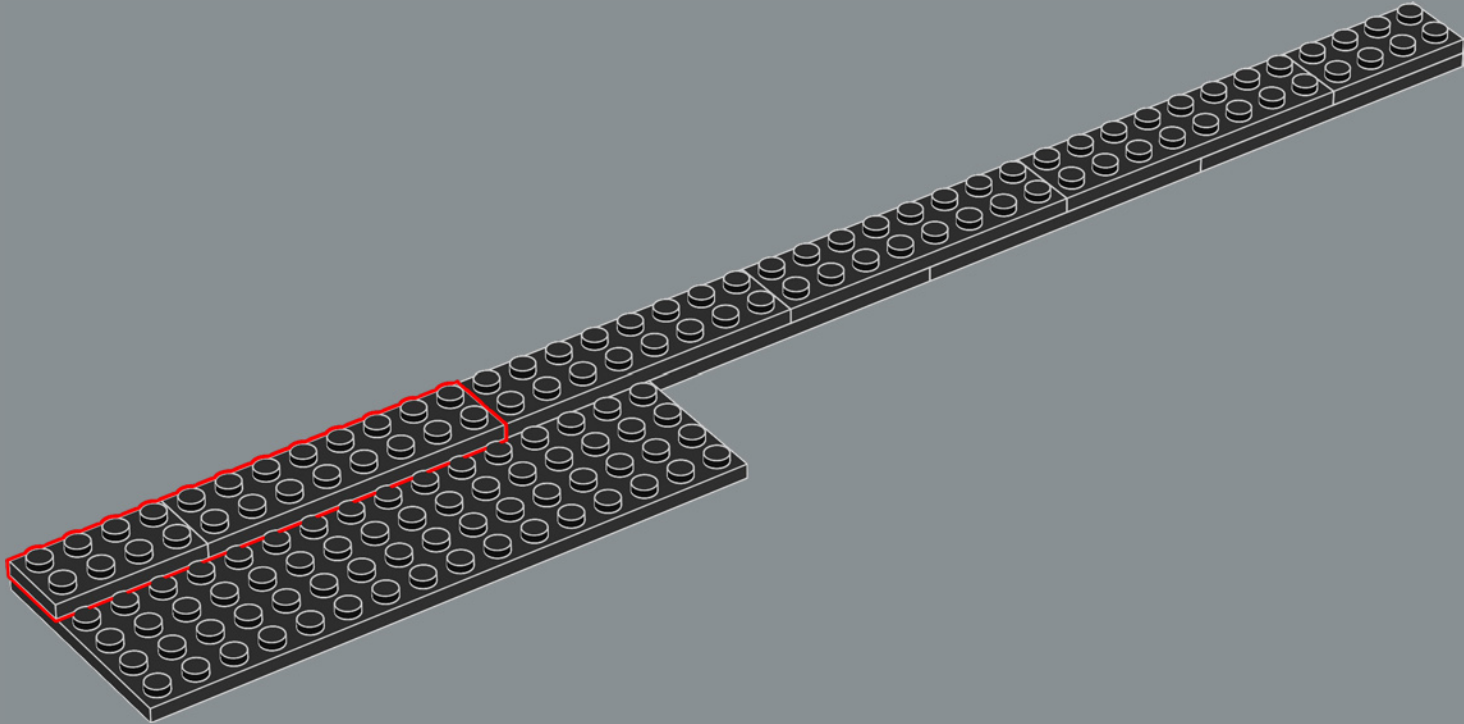

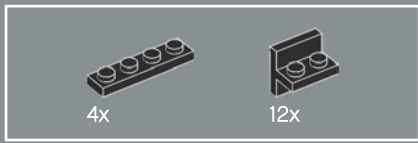

7

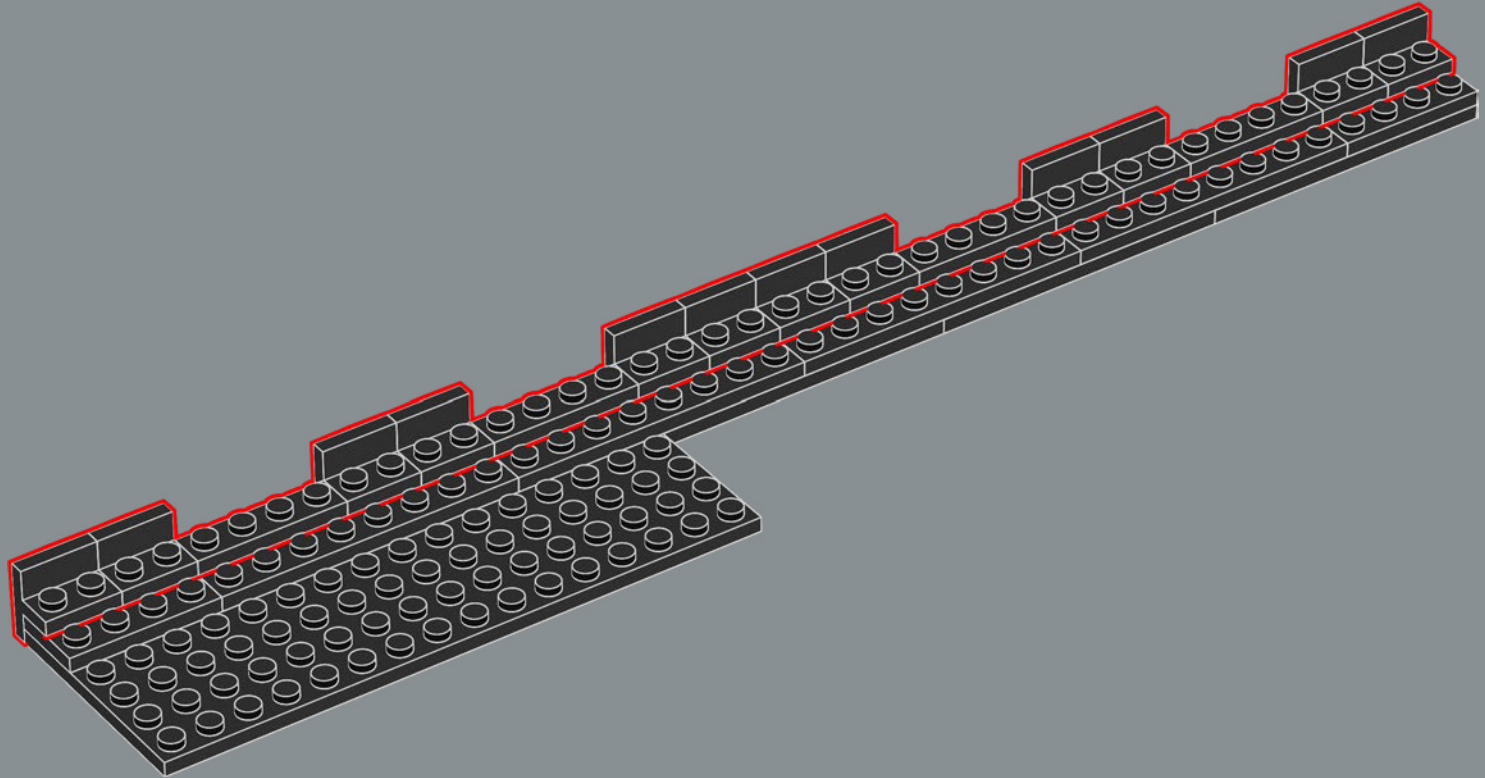

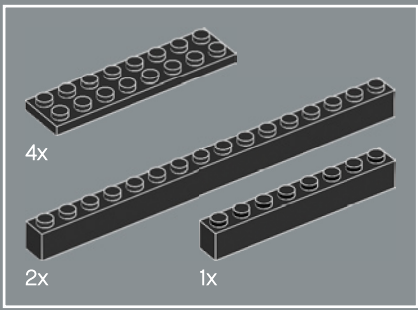

8

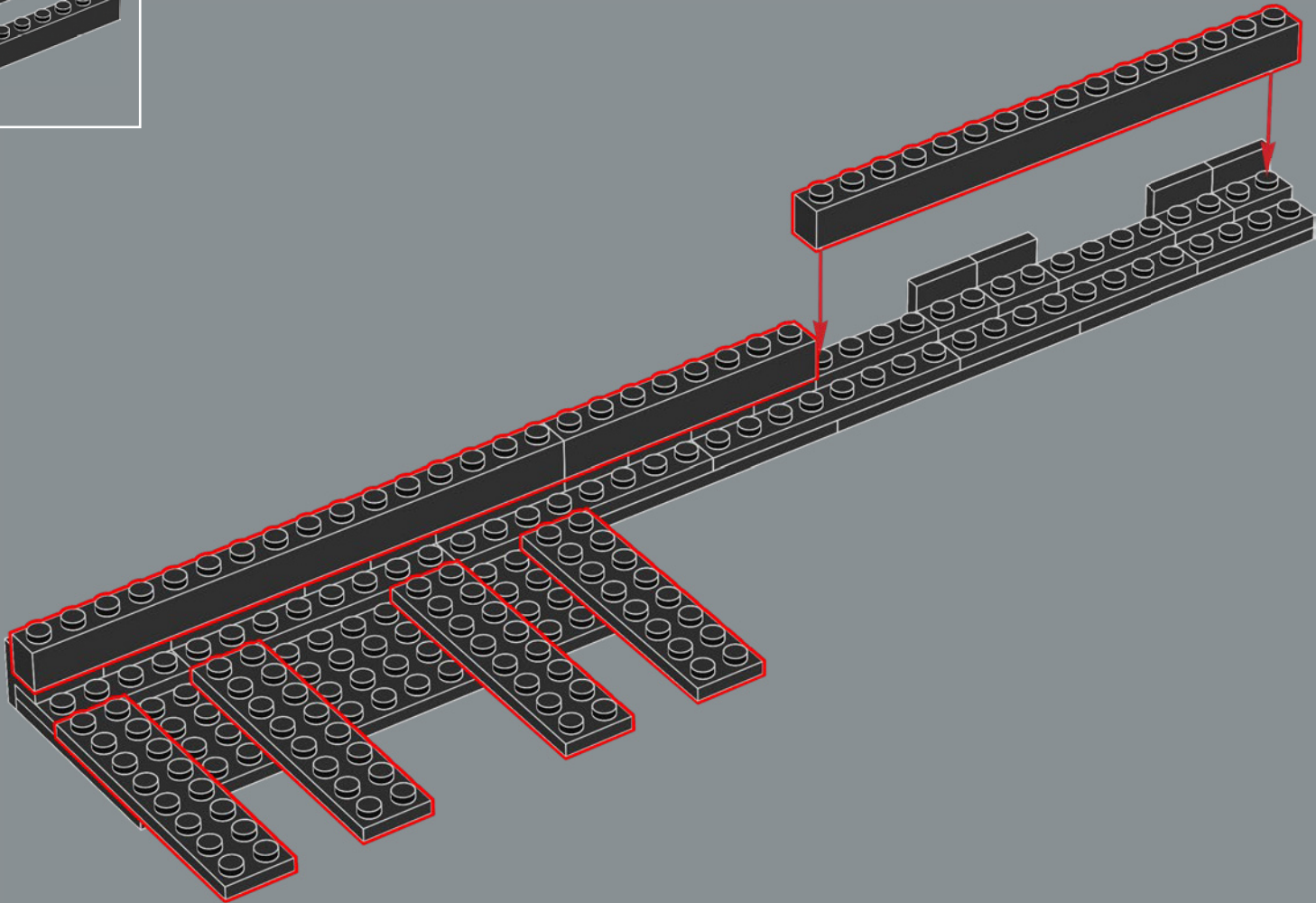

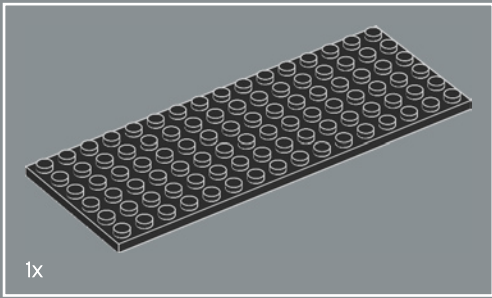

9

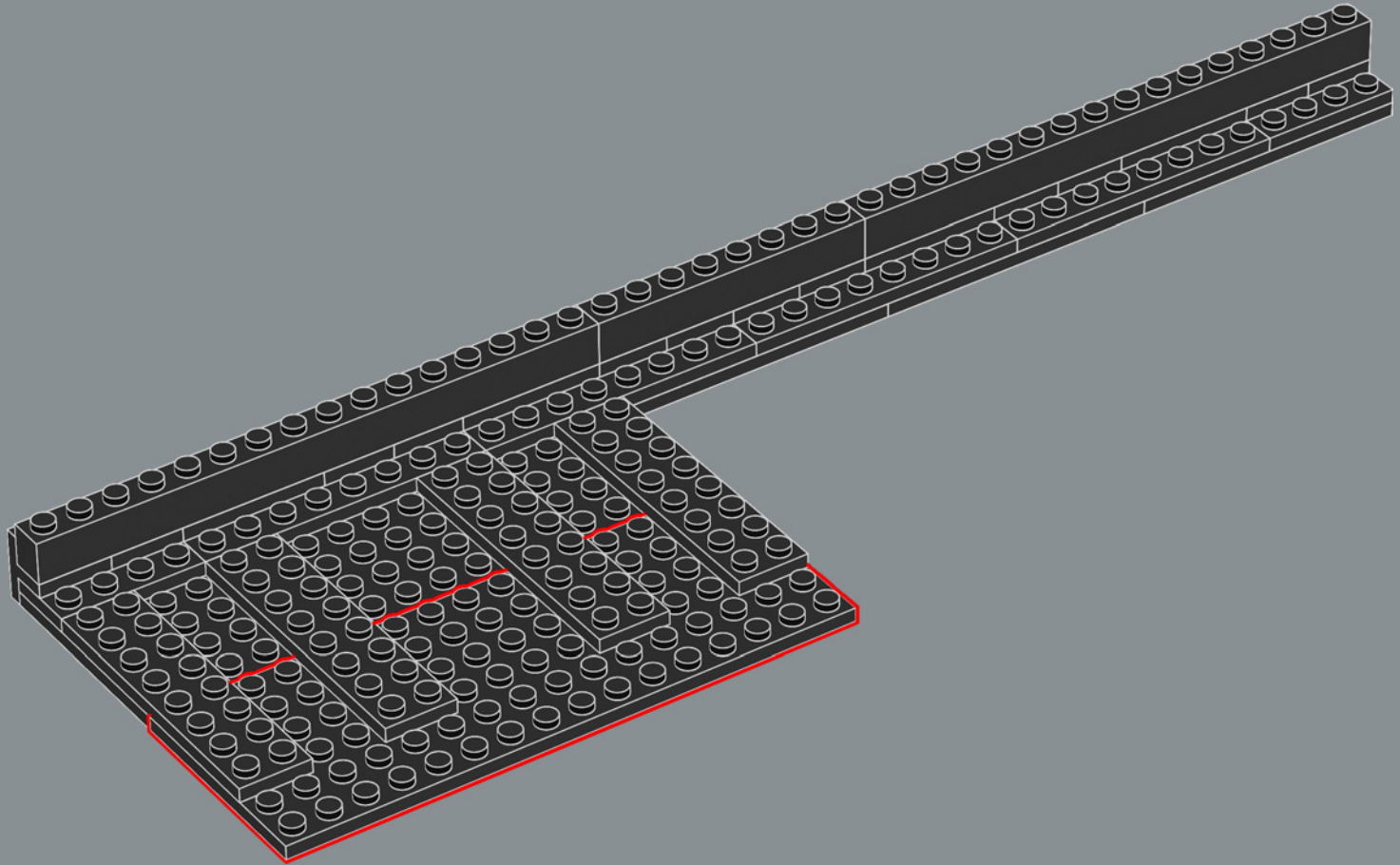

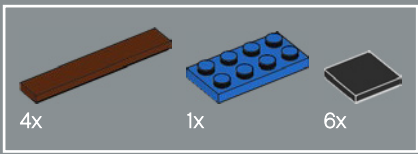

10

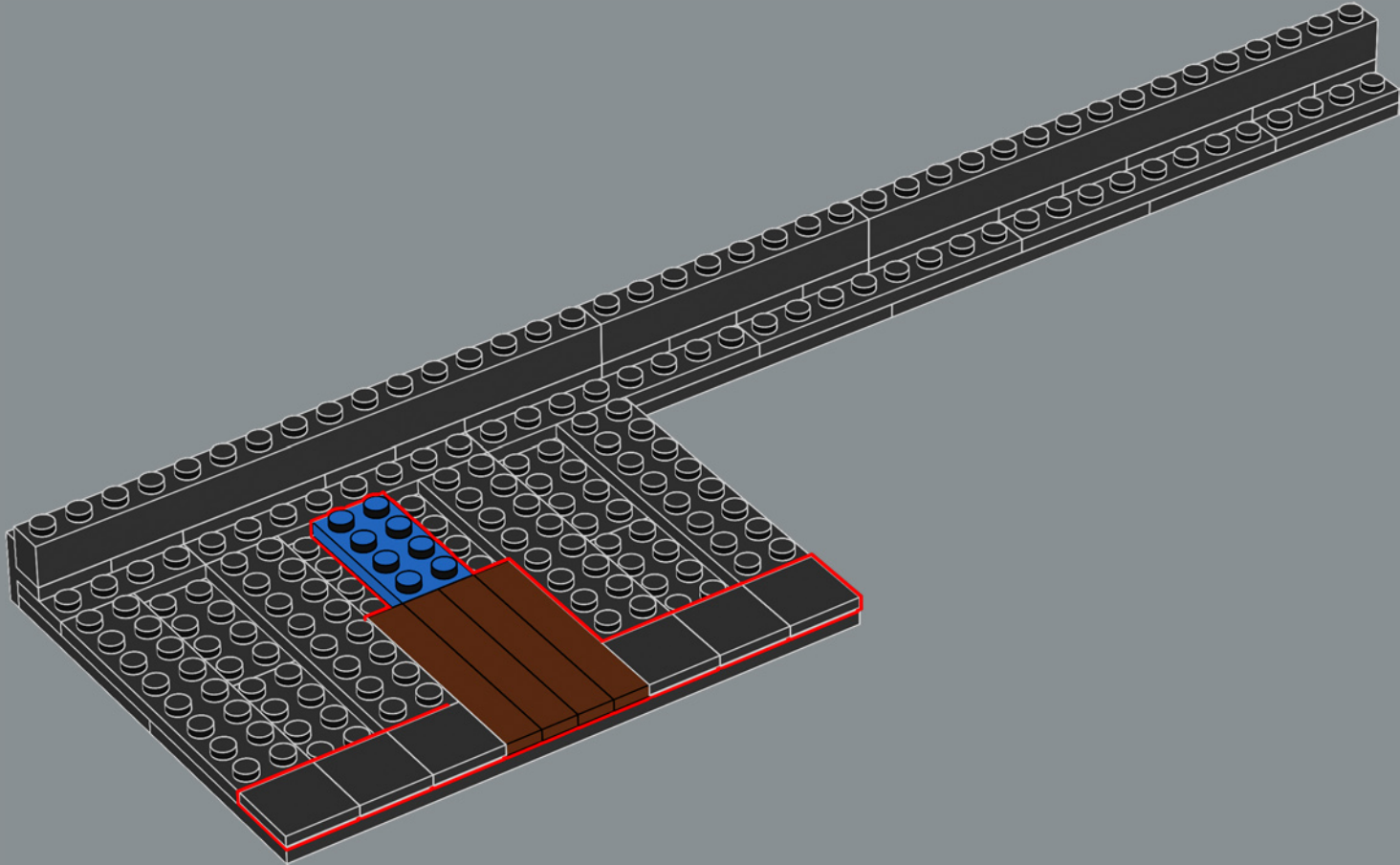

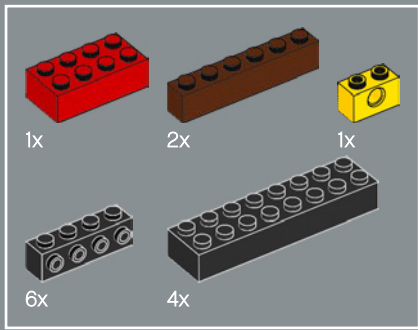

11

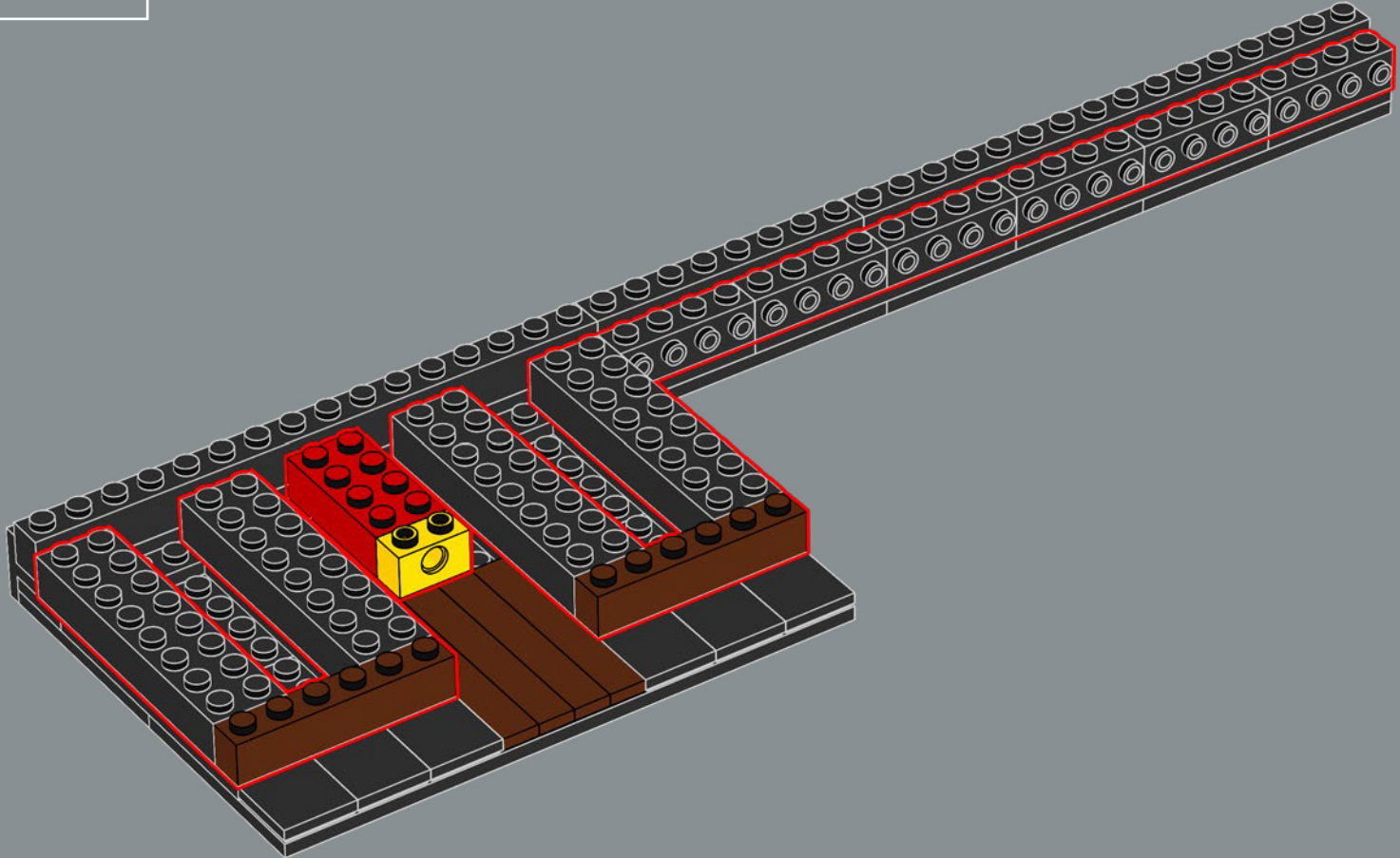

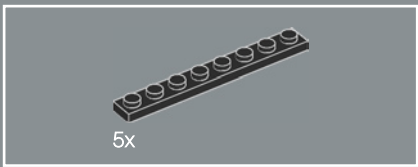

12

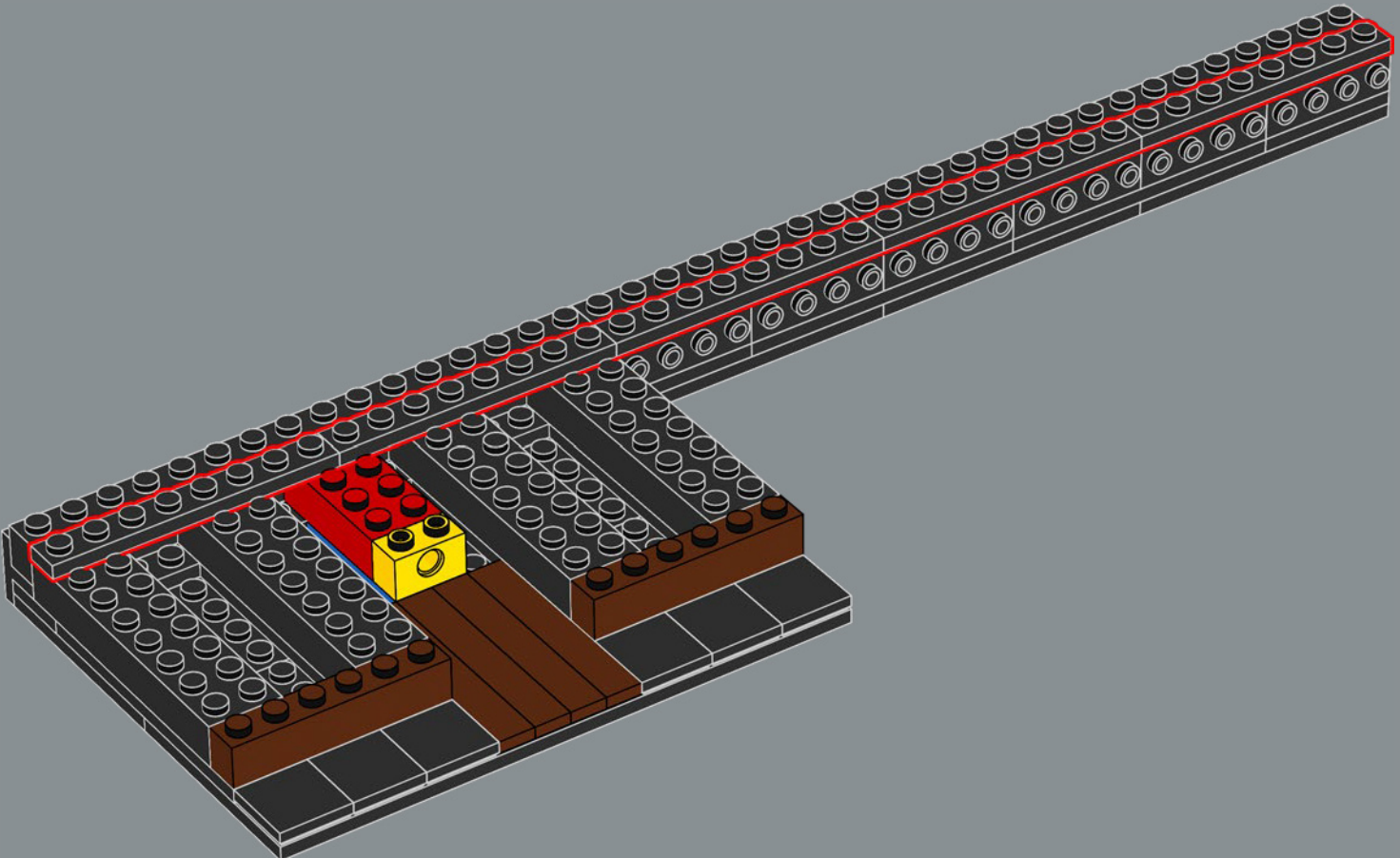

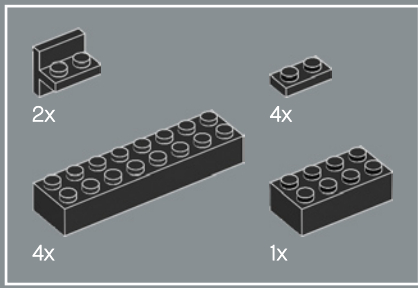

13

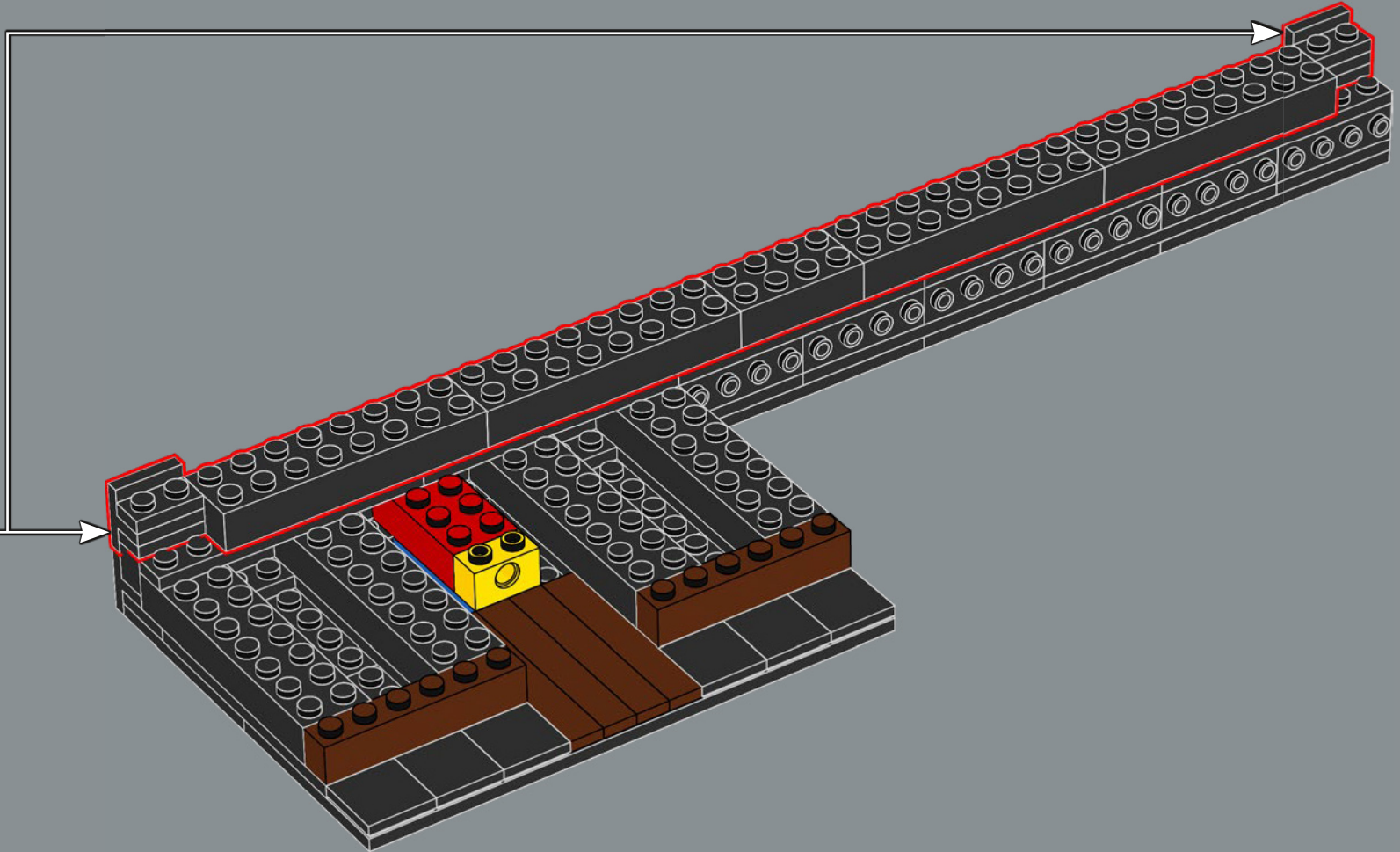
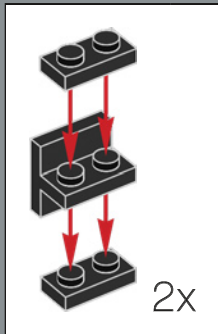

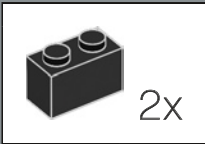
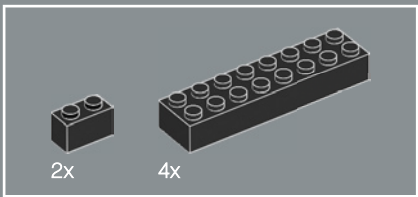

14

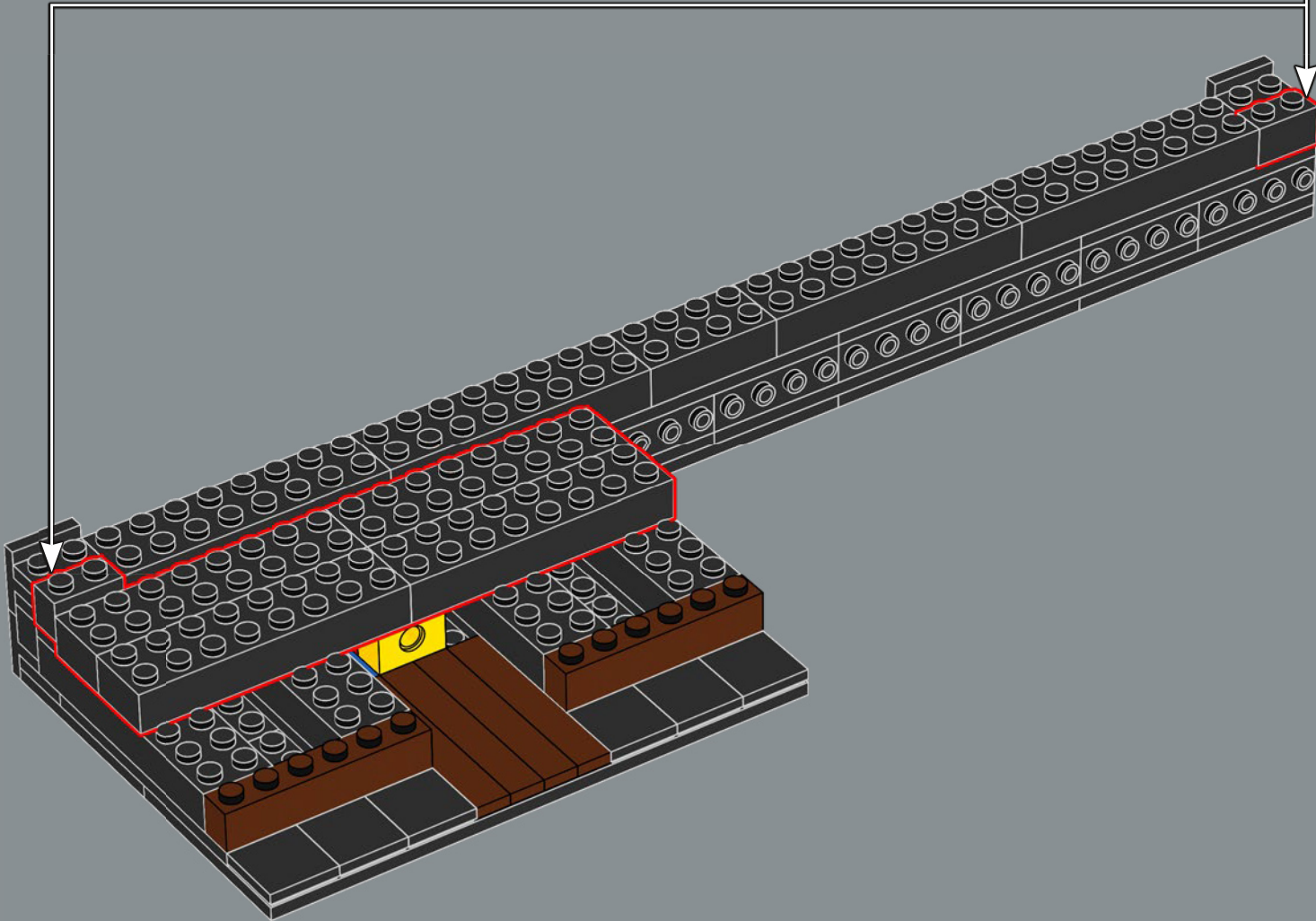

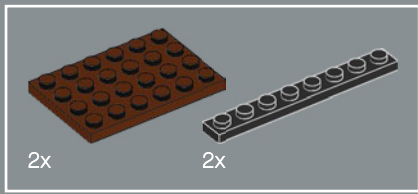

15

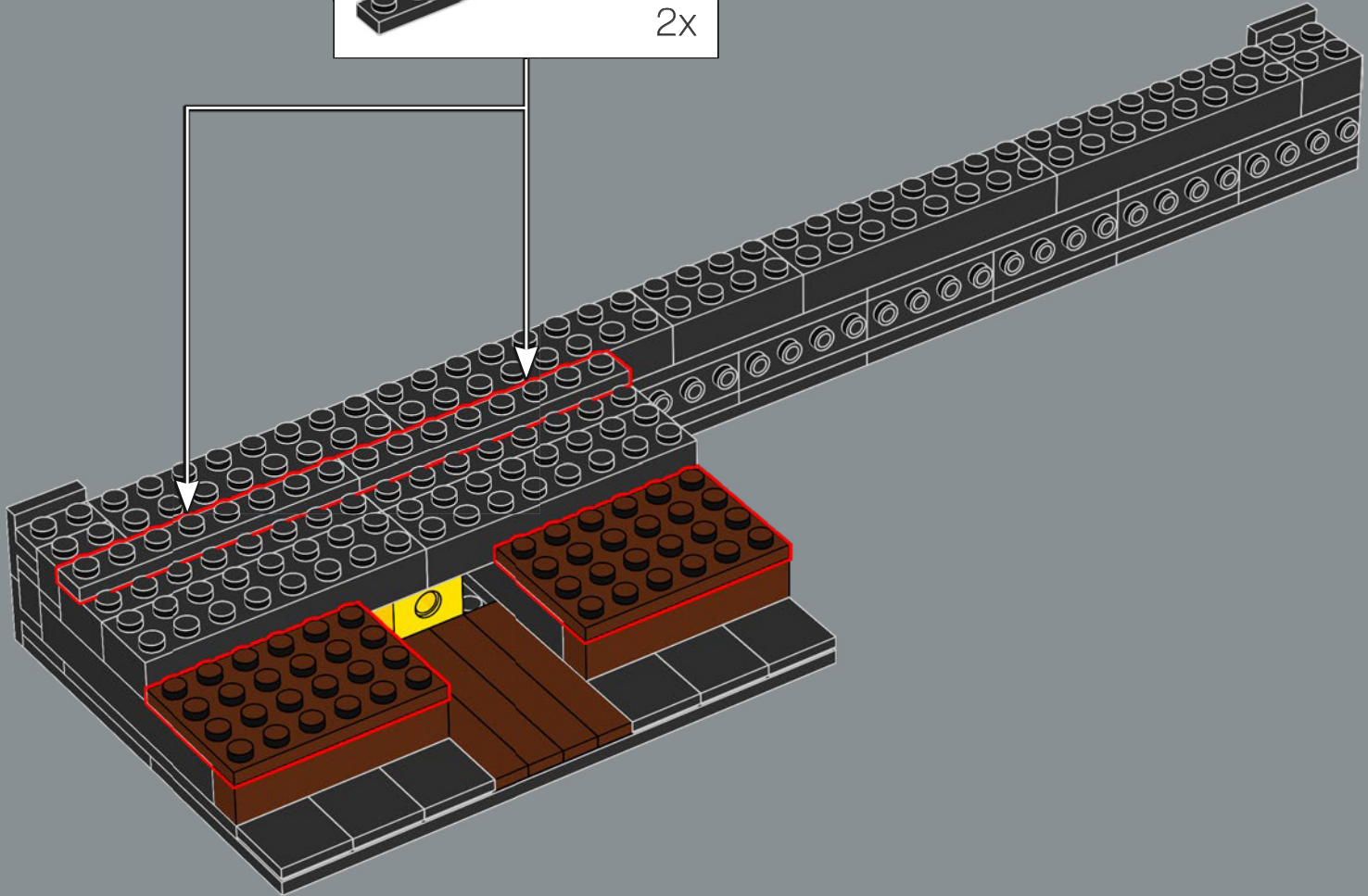
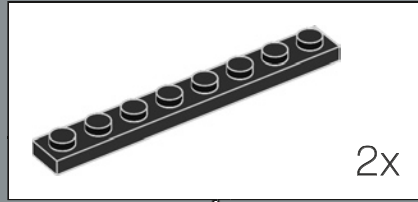

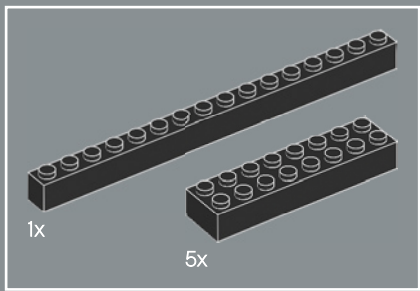

16

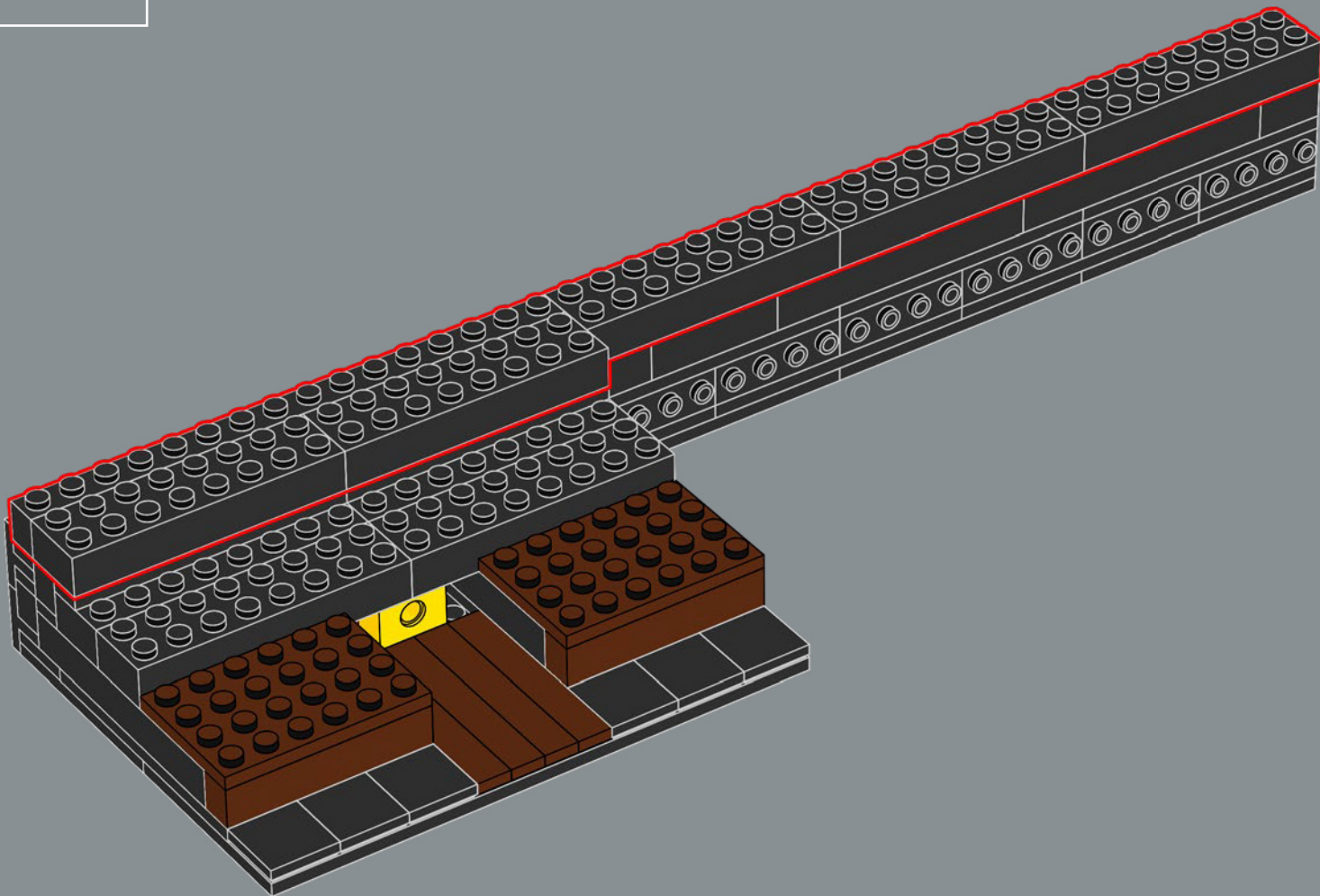

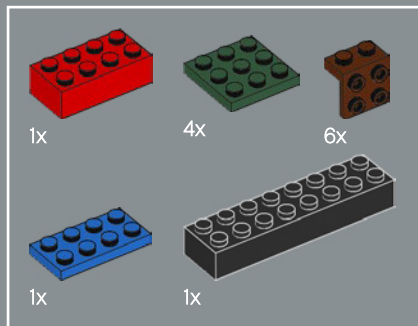

17

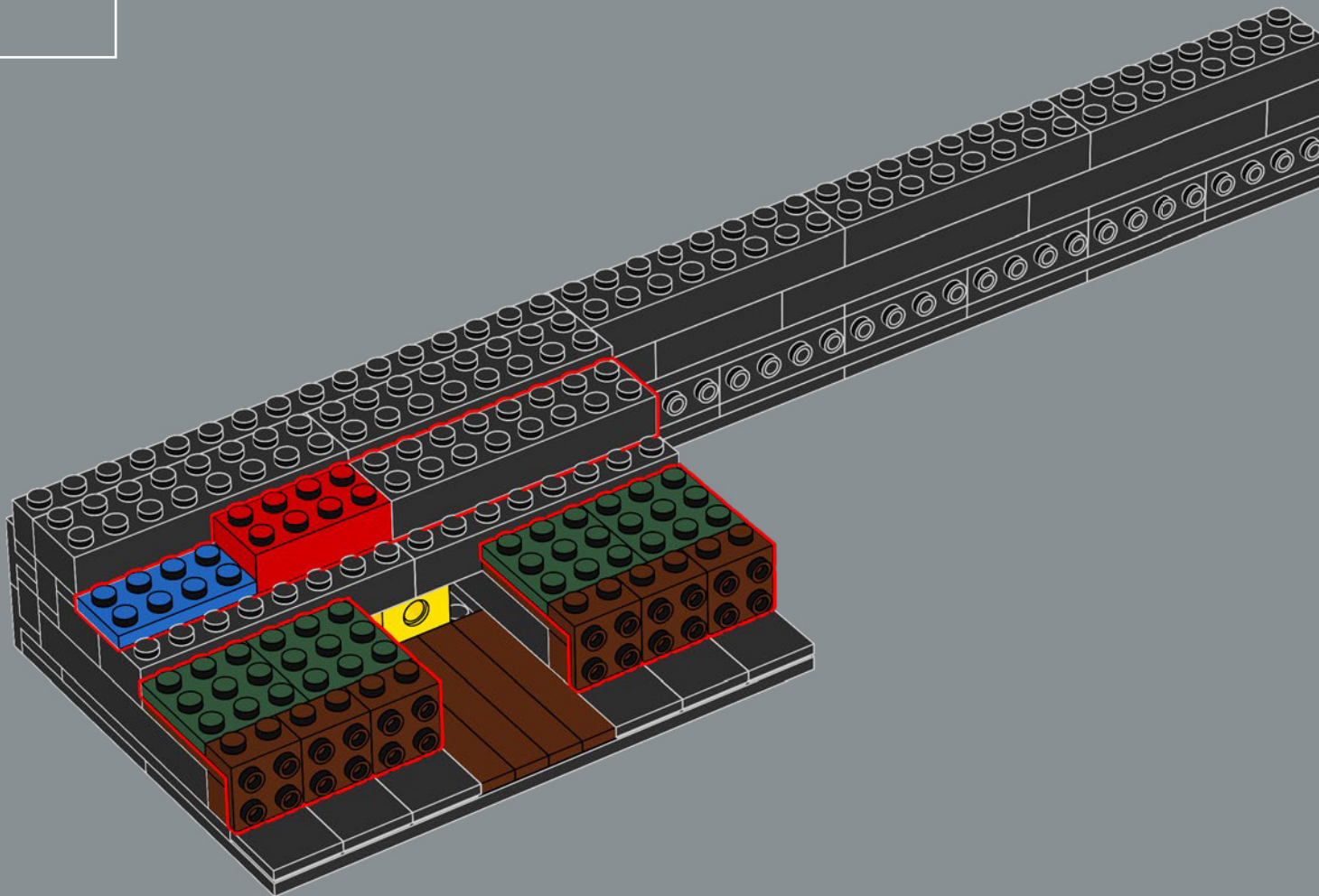

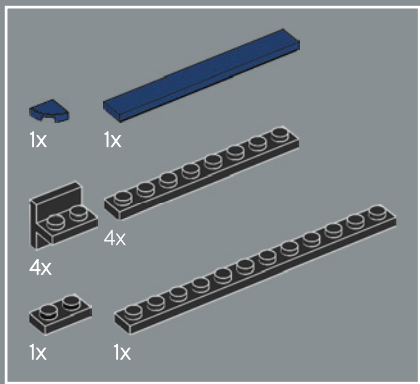

18

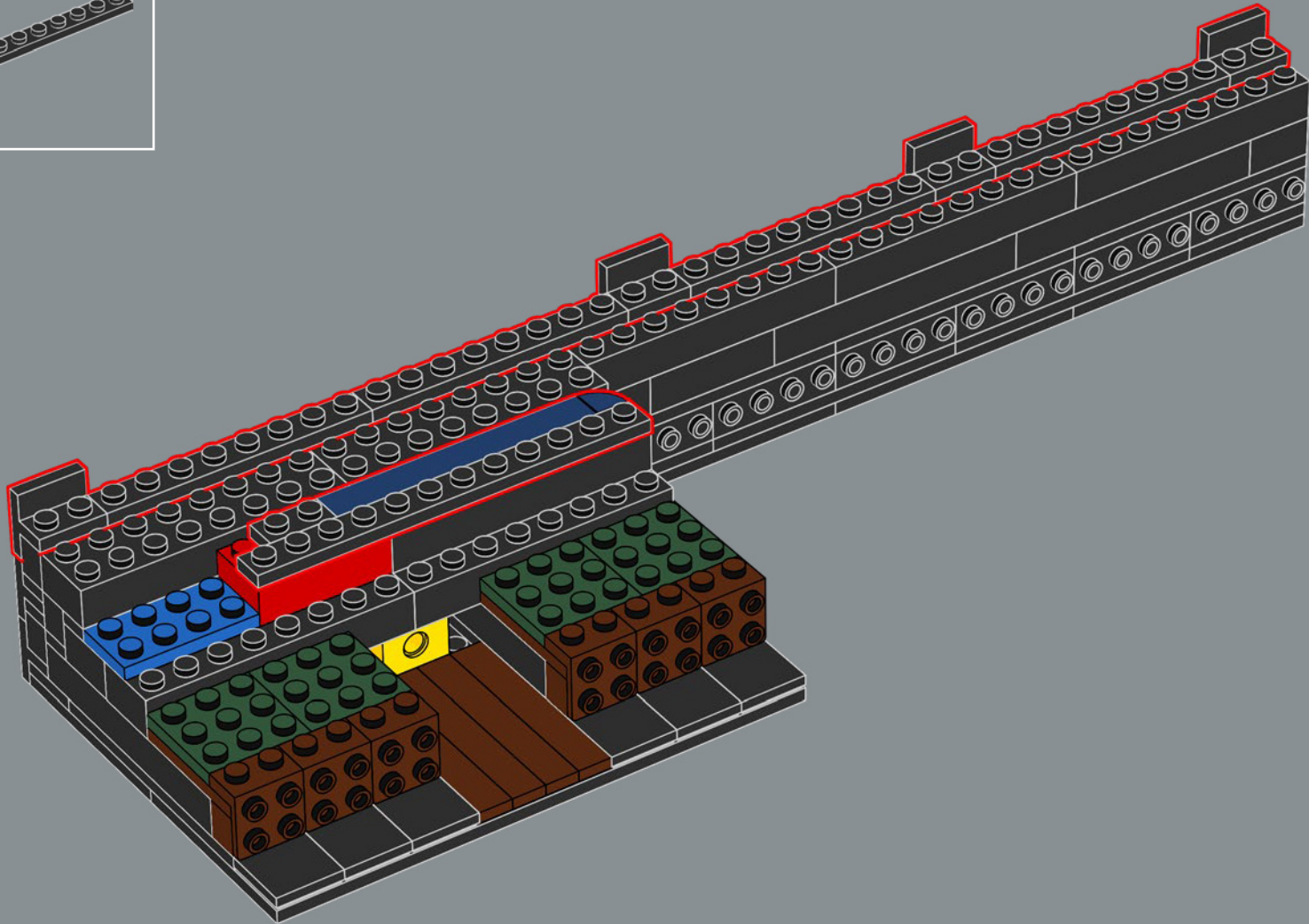

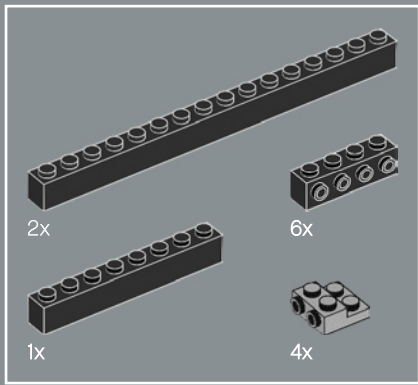

19

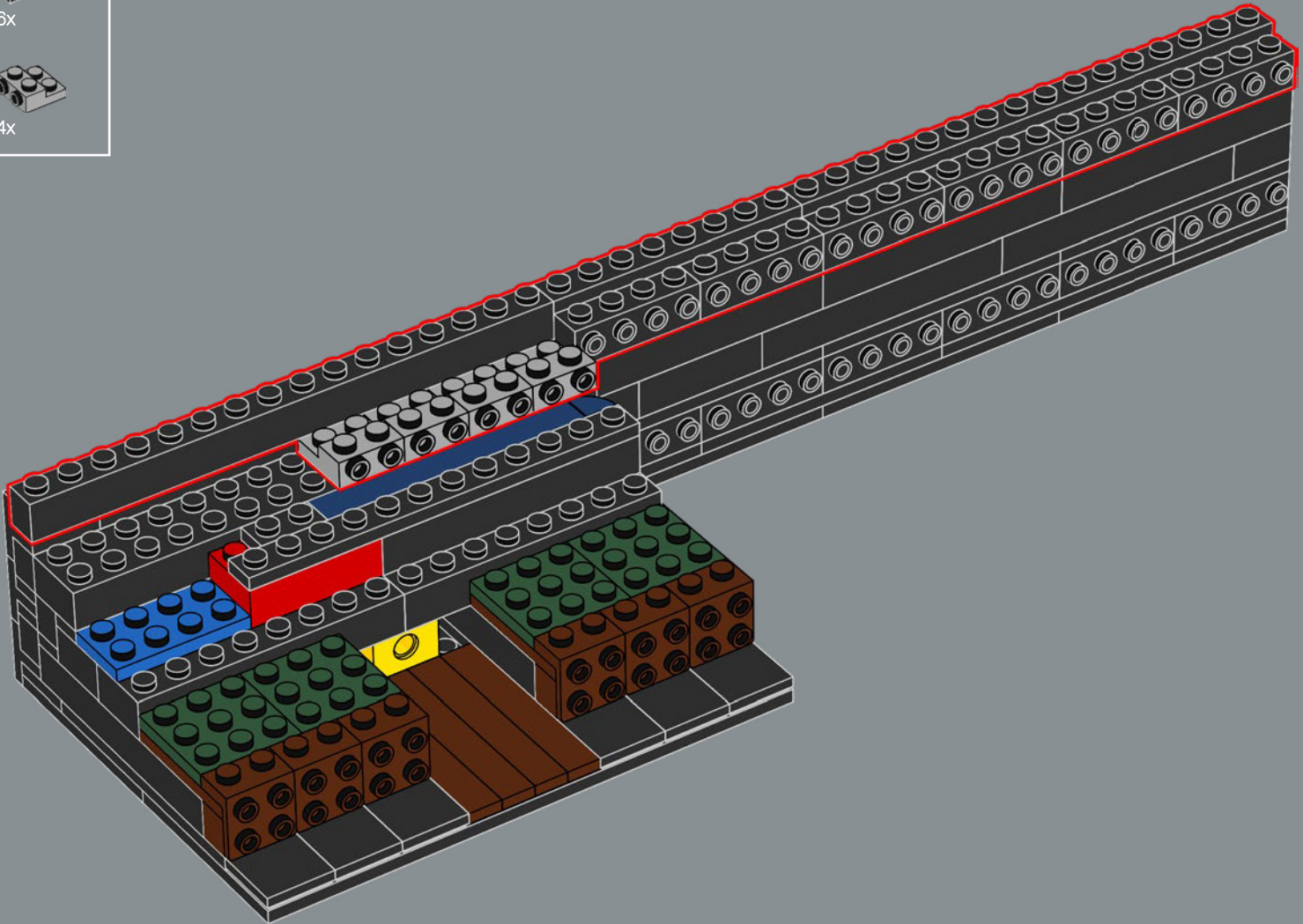

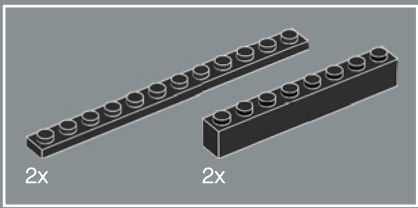

20

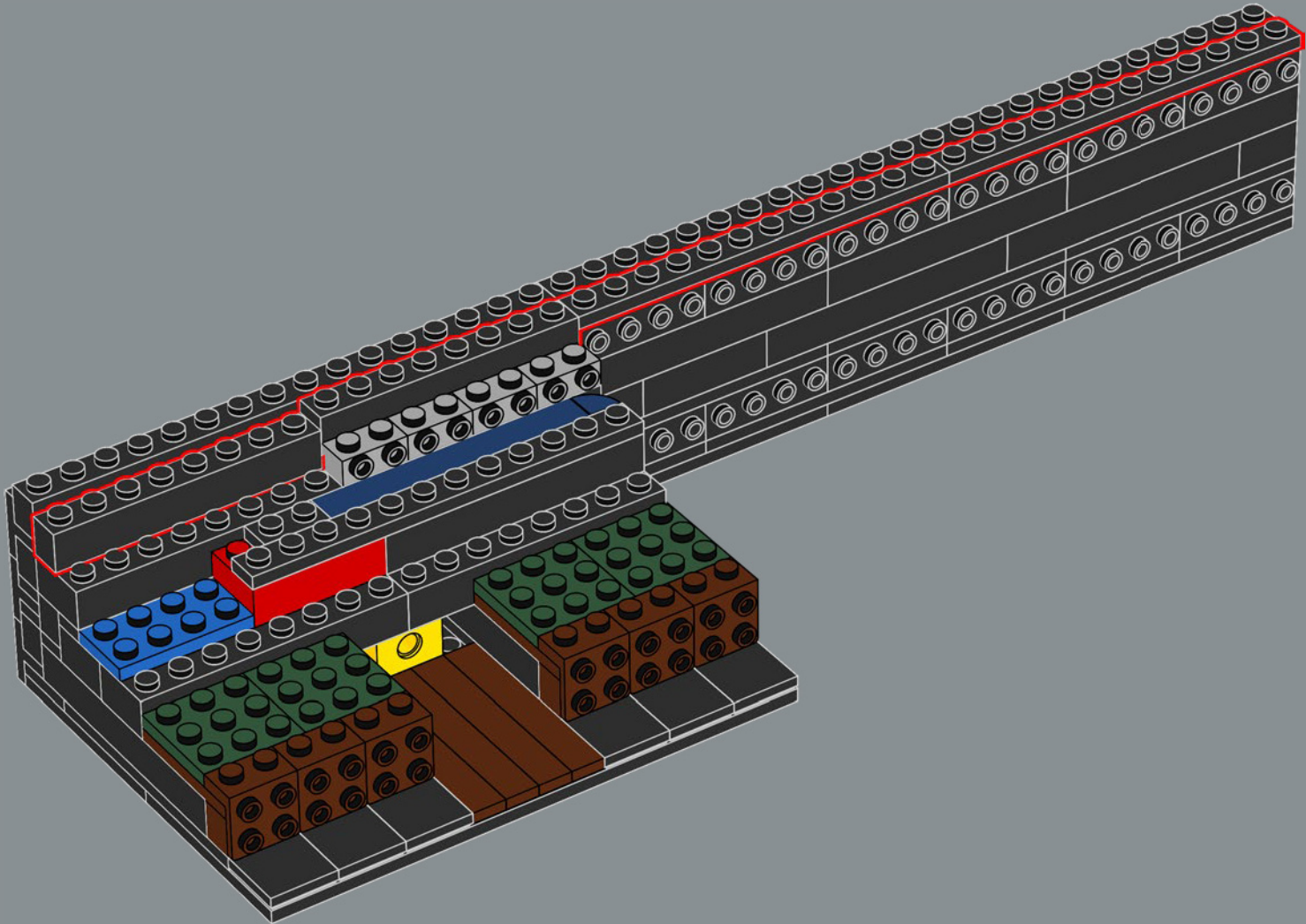

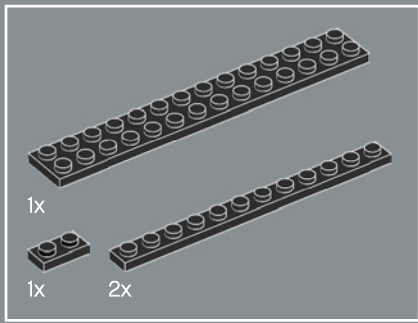

21

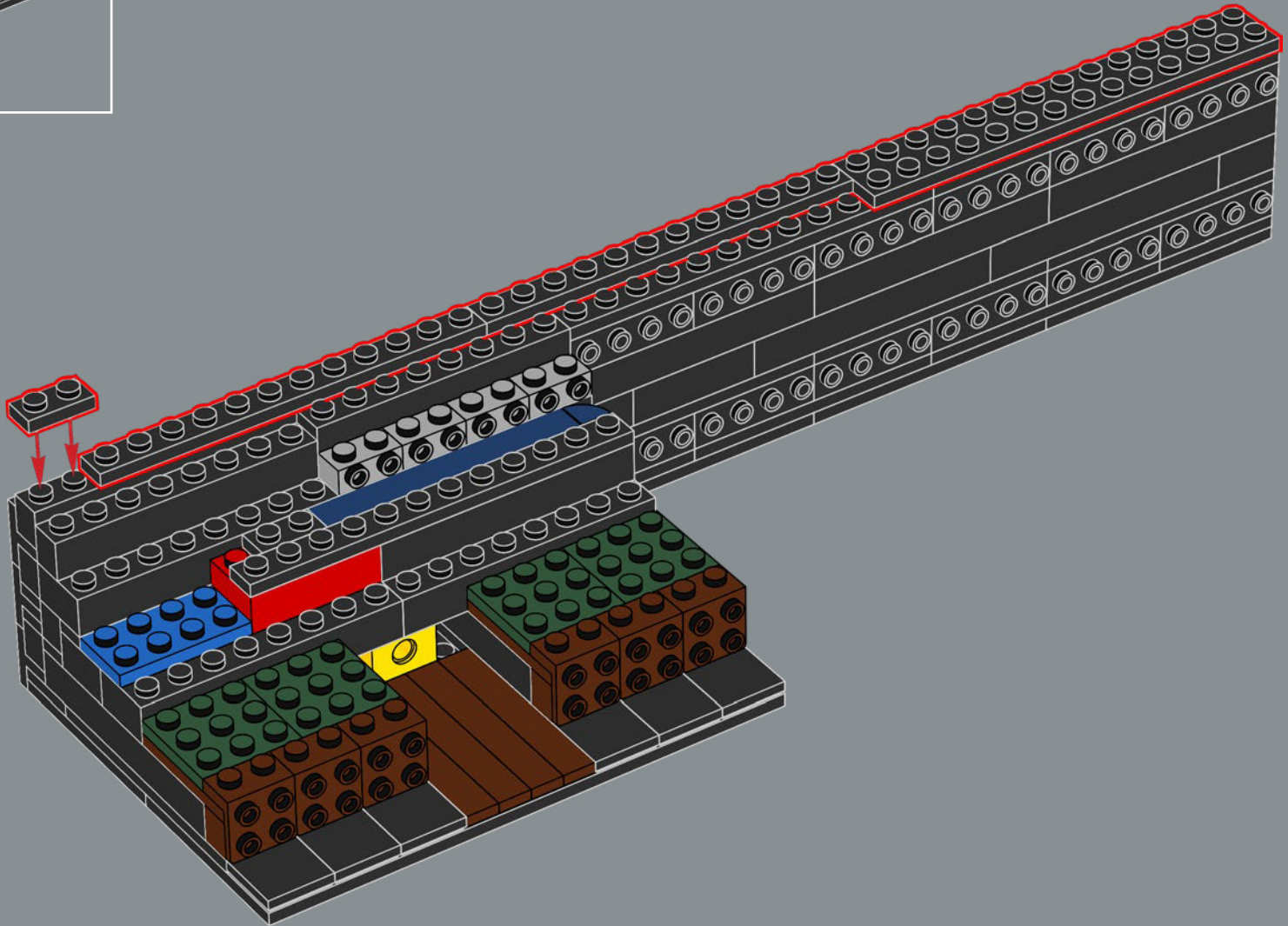

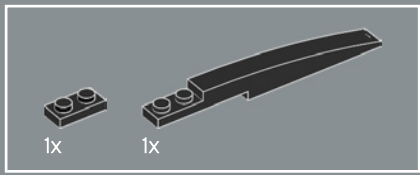

22

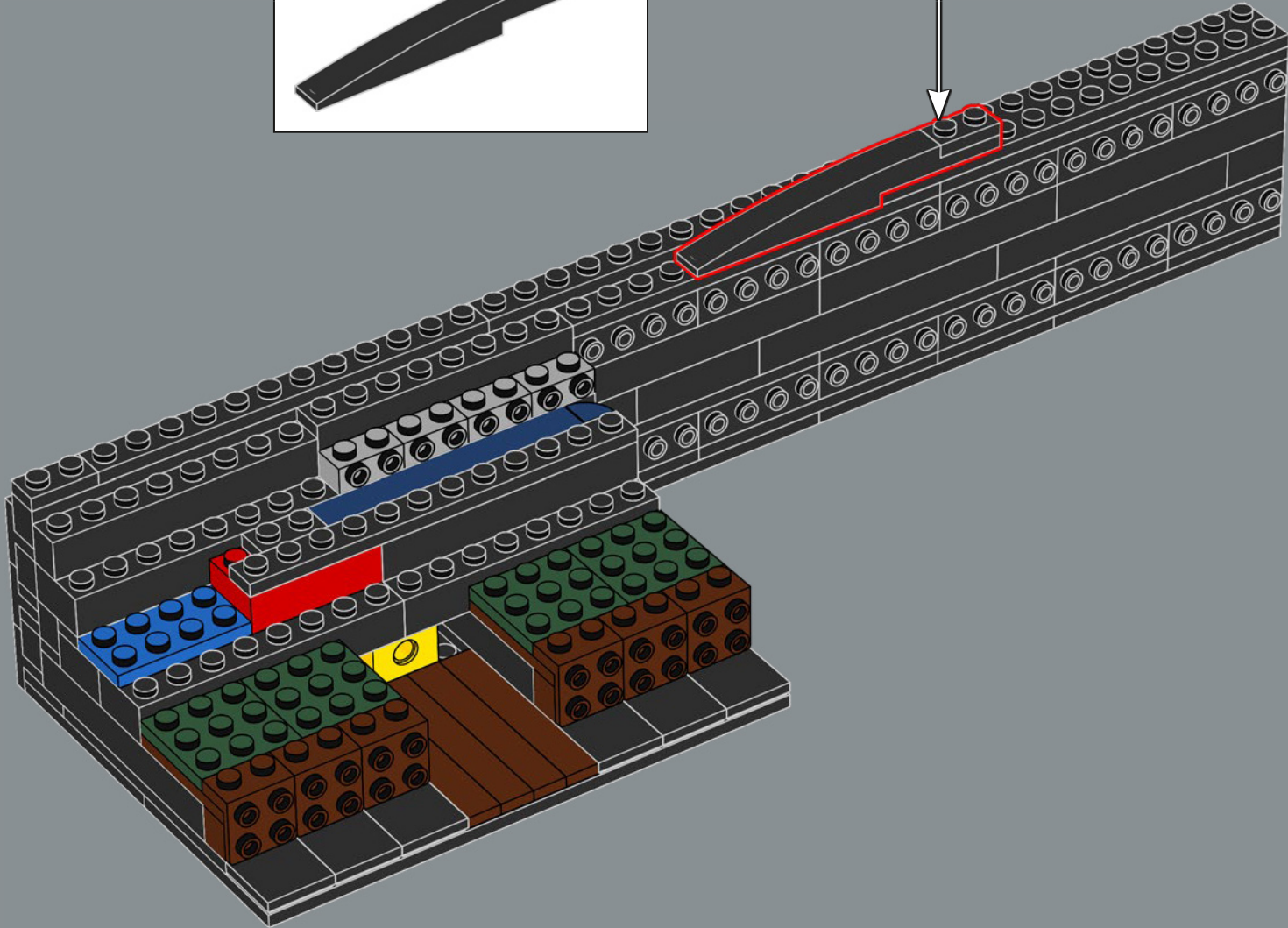
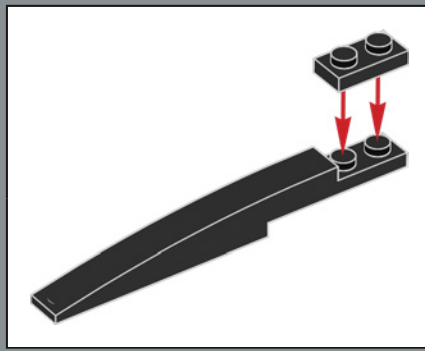

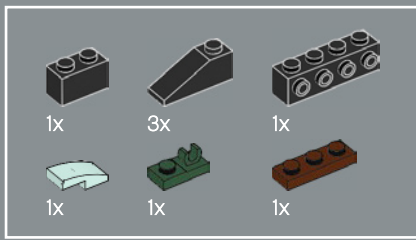

23

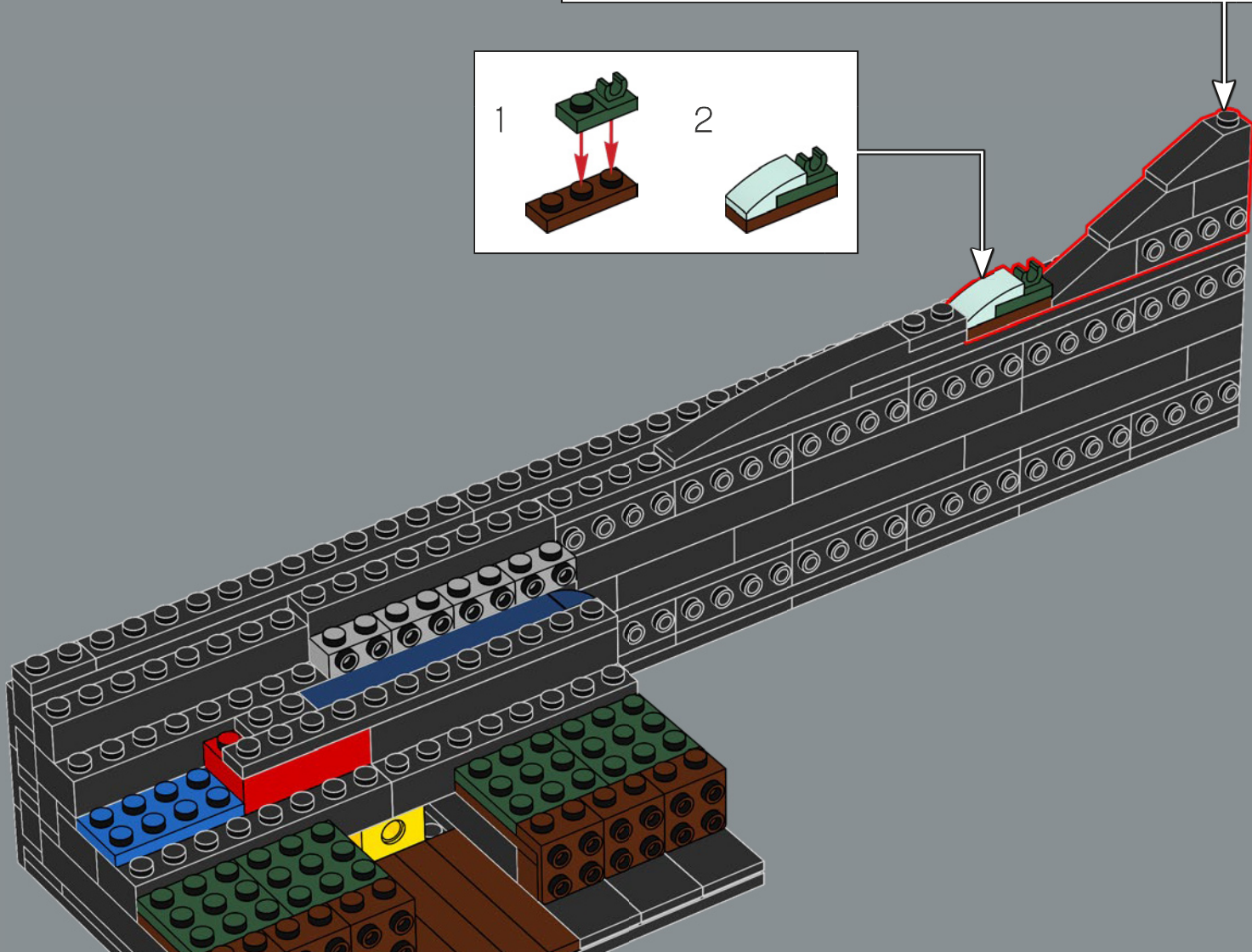
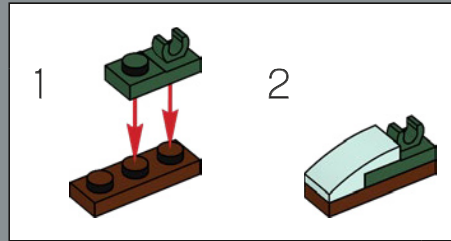
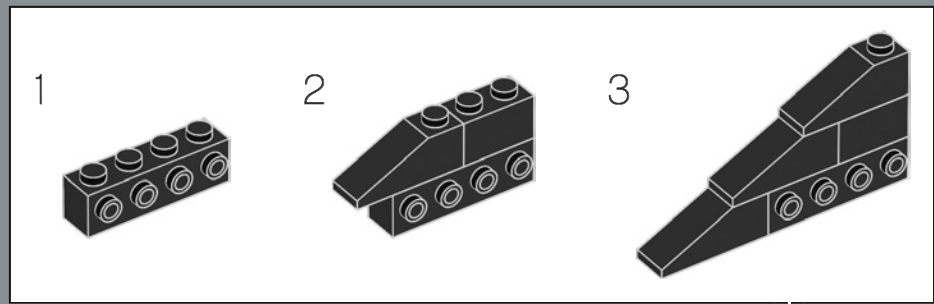

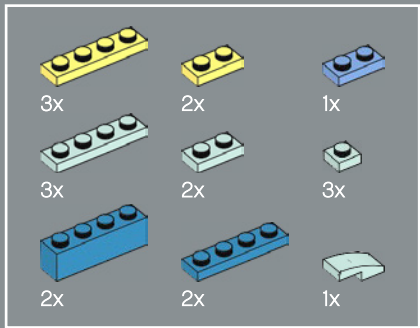

24

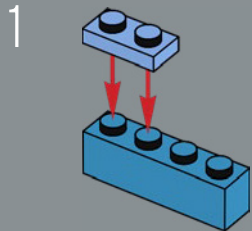

2

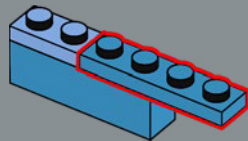

3

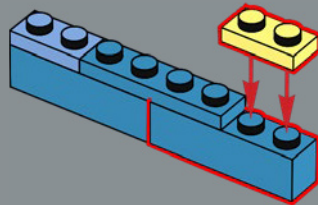

4

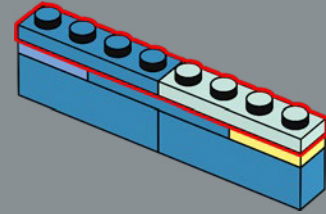

5

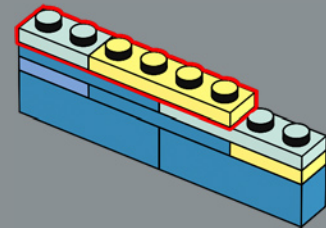

6

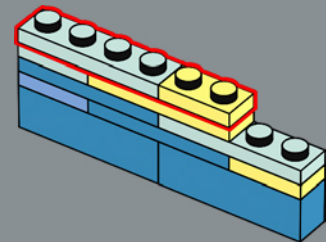

7

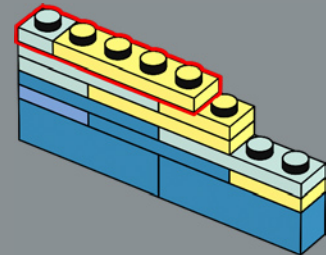

8

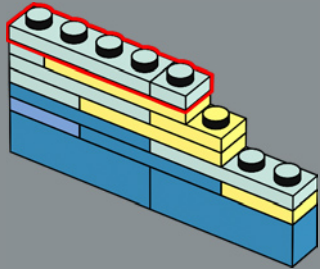

9

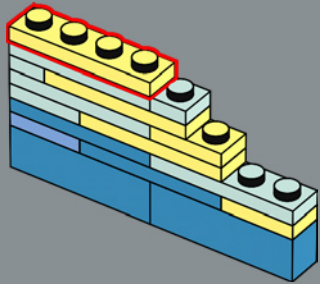

10

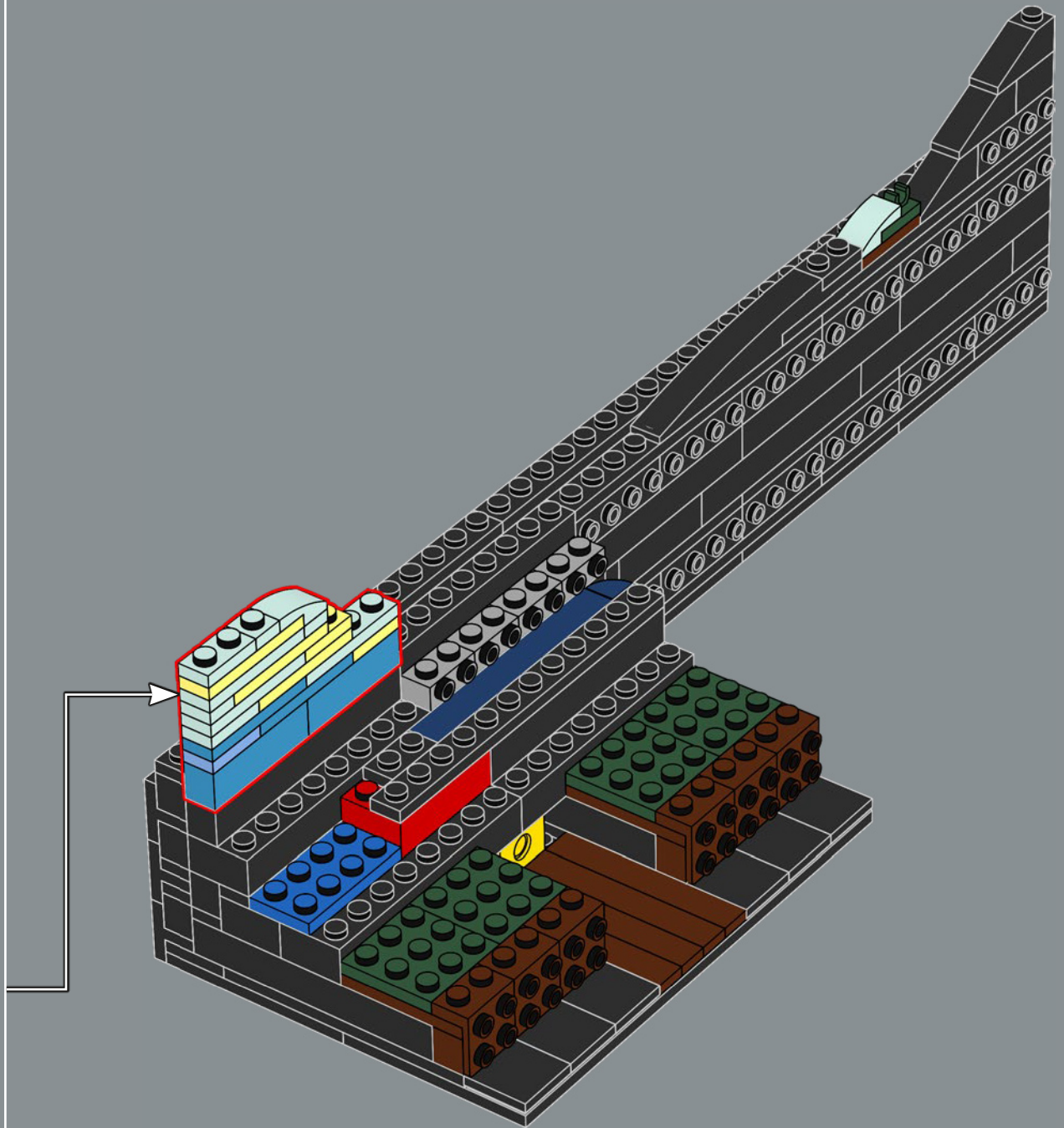
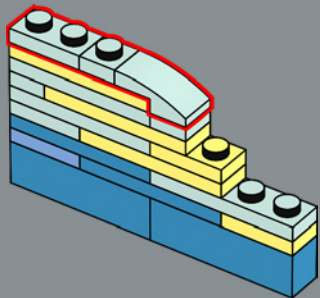

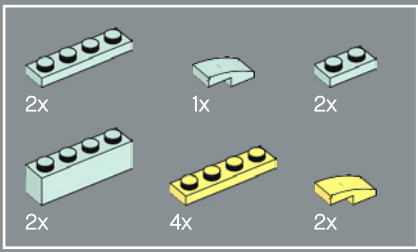

25

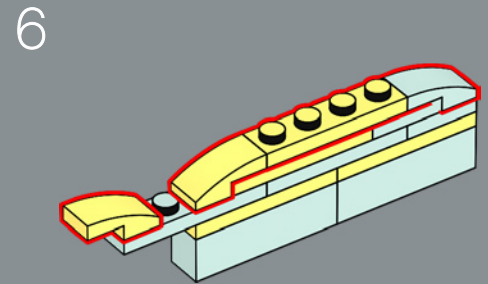
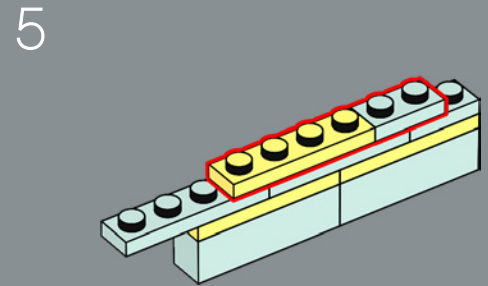
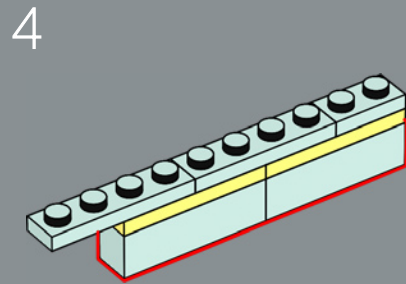
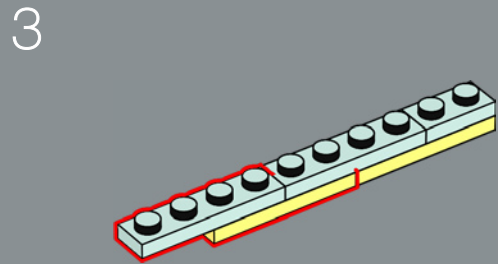
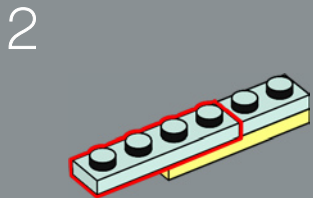
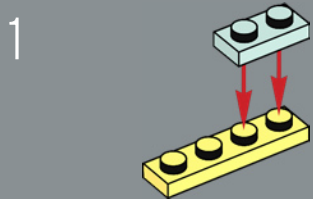

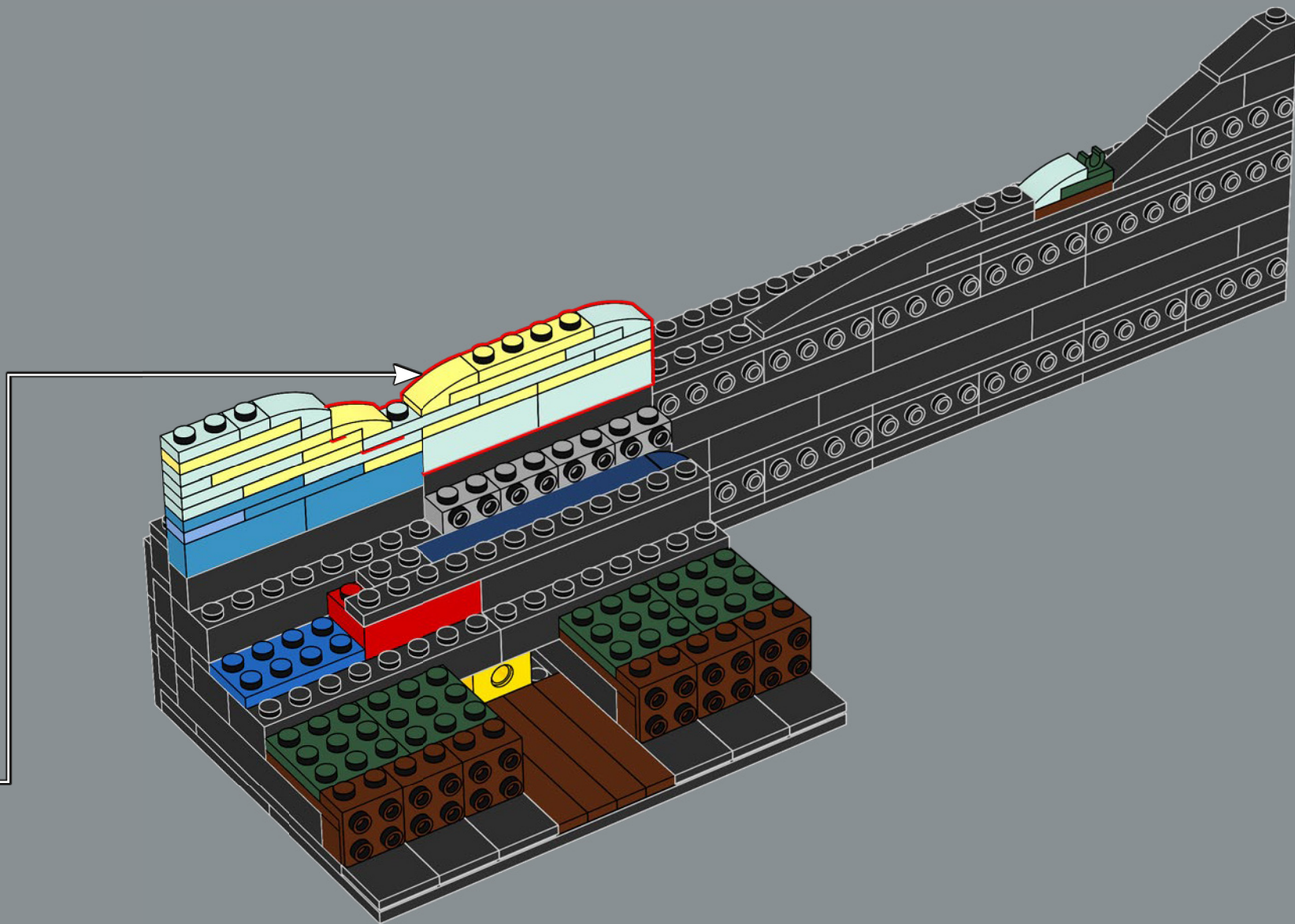

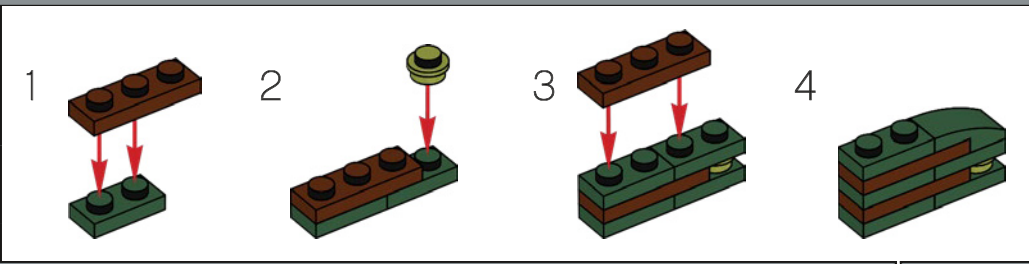
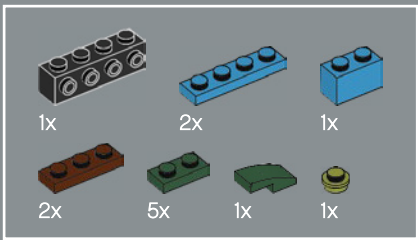

26

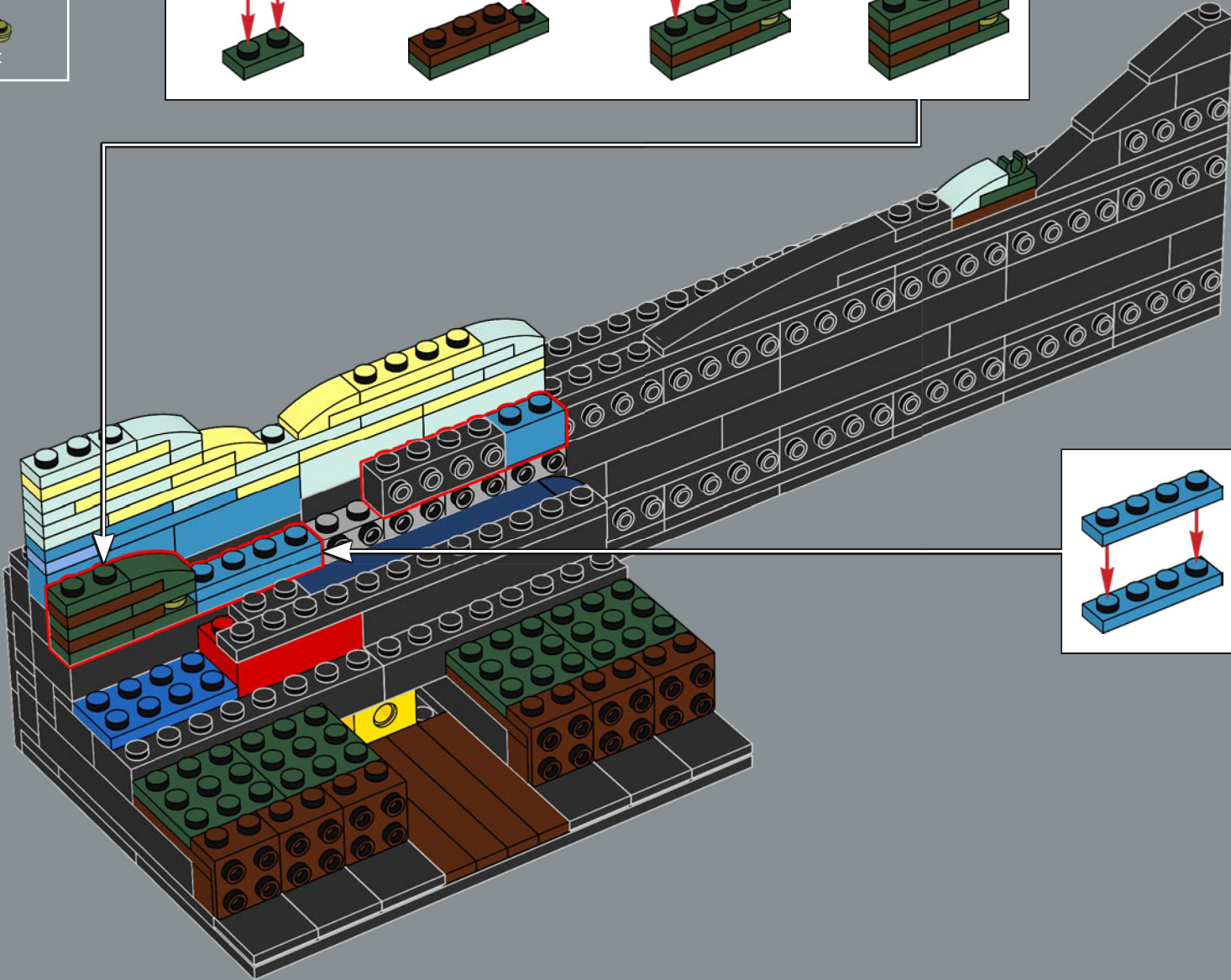

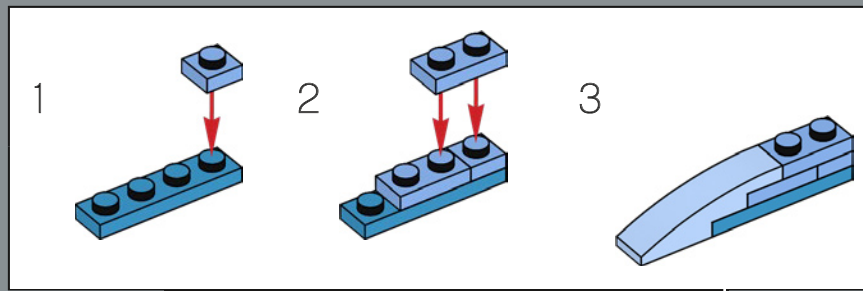
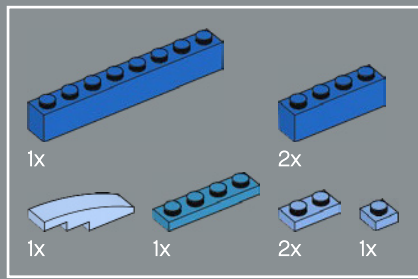

27

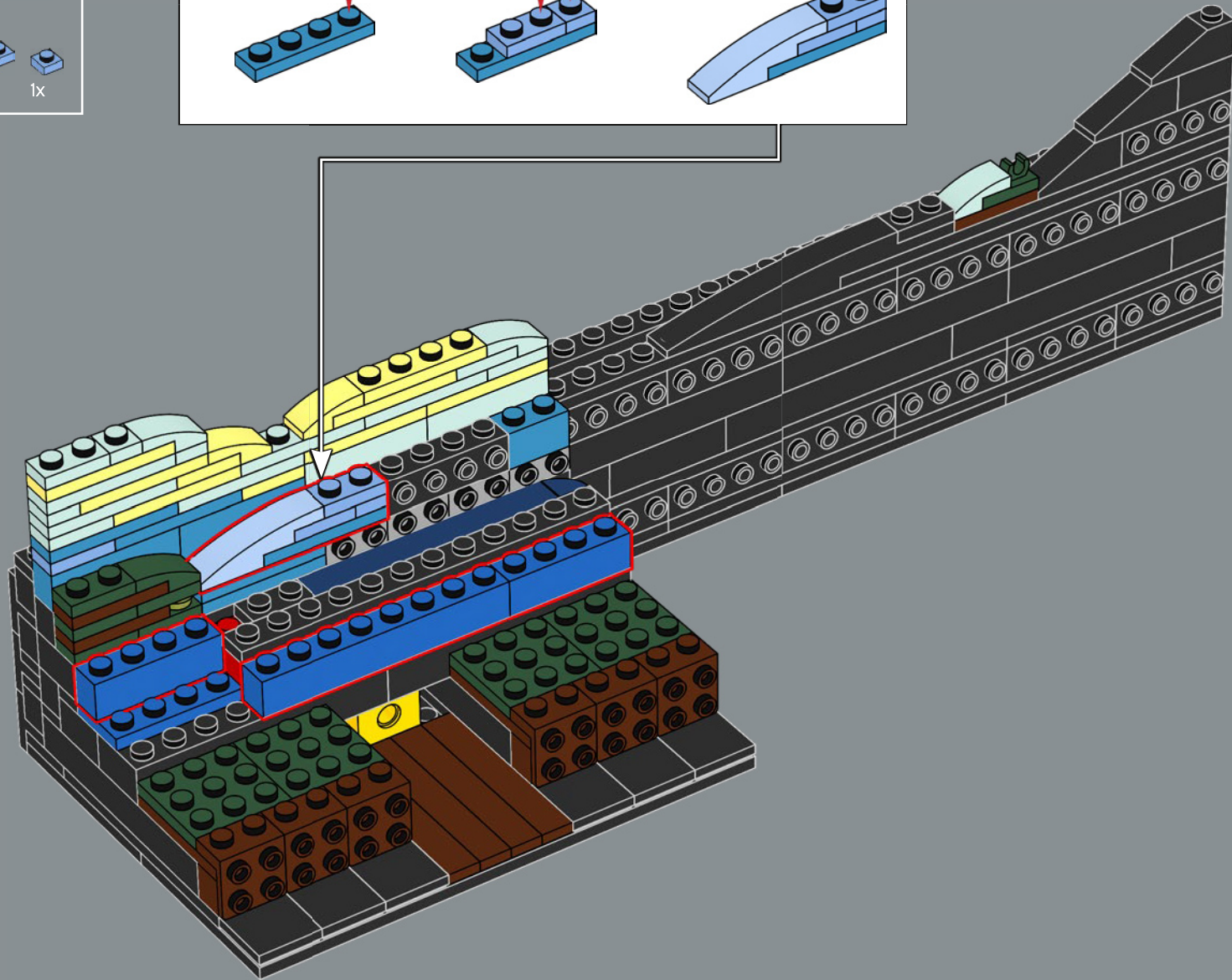

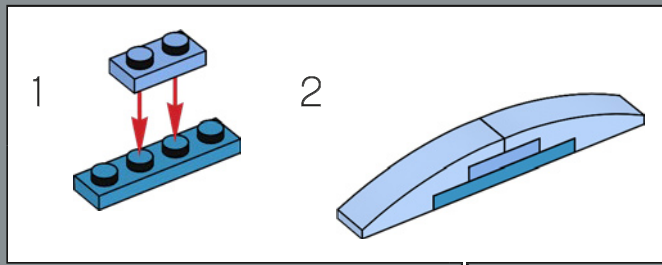
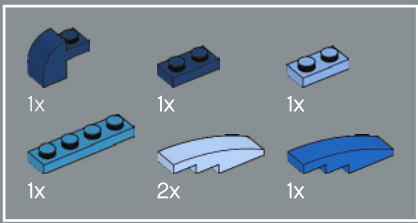

28

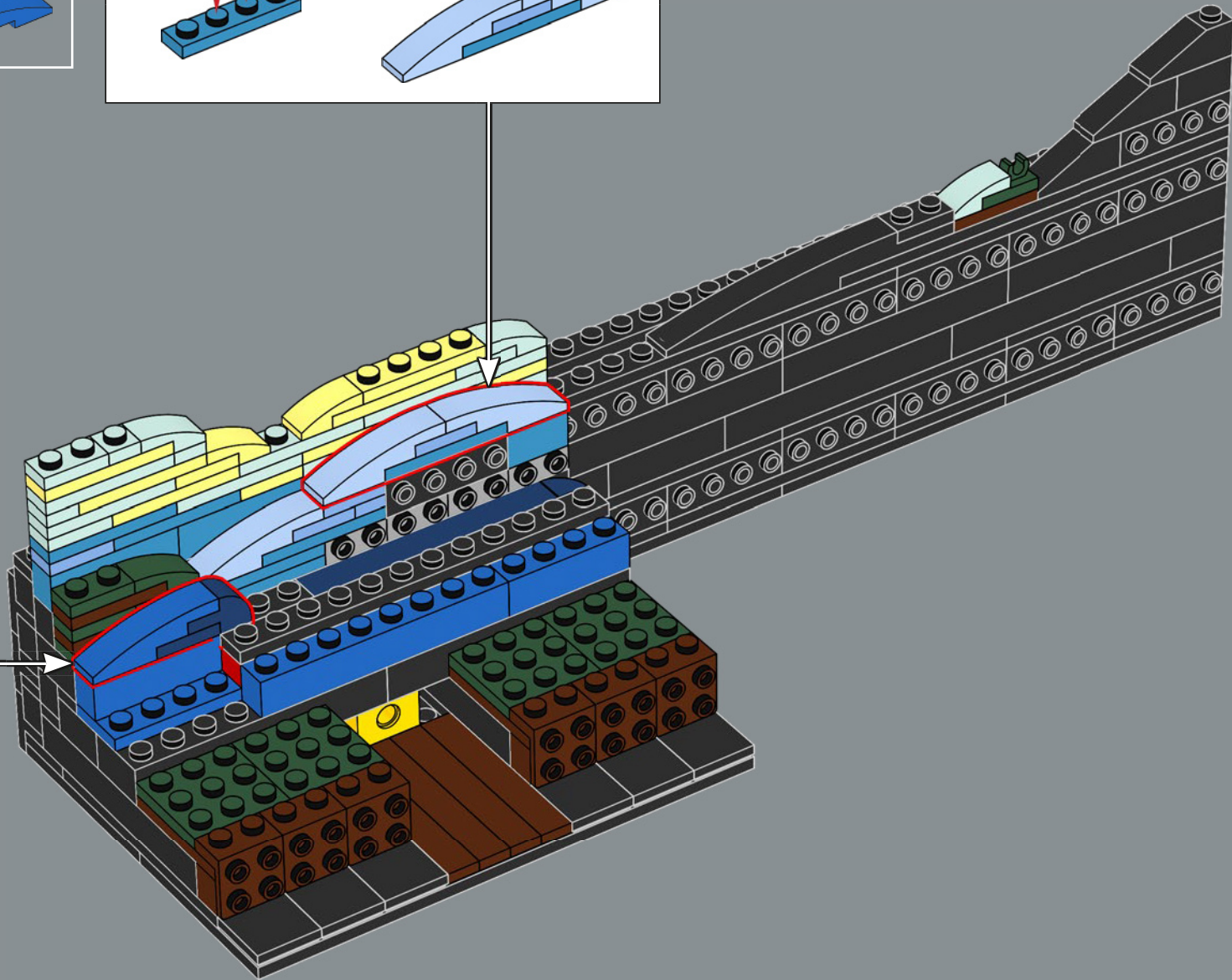
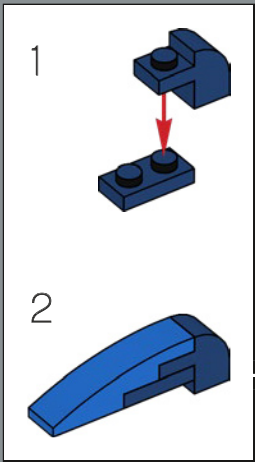

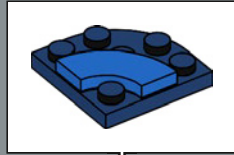
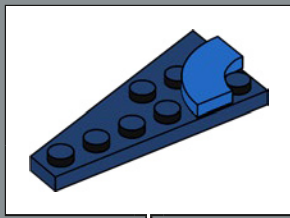
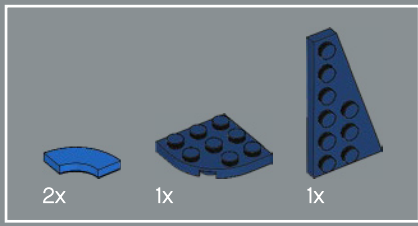

29

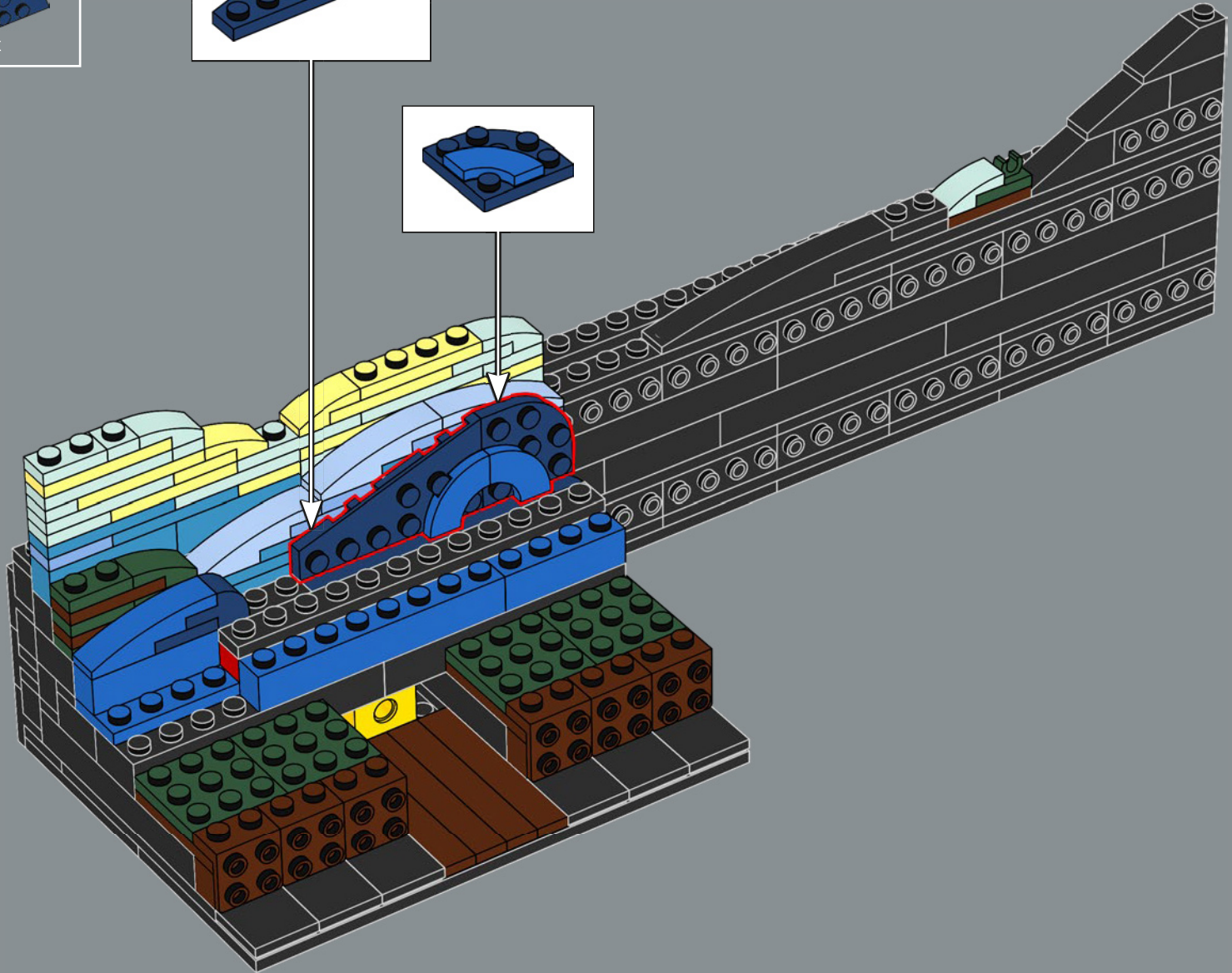

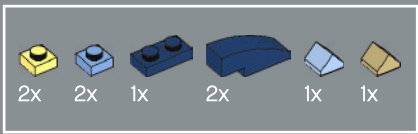

30

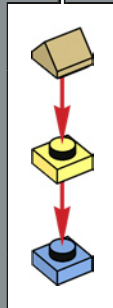
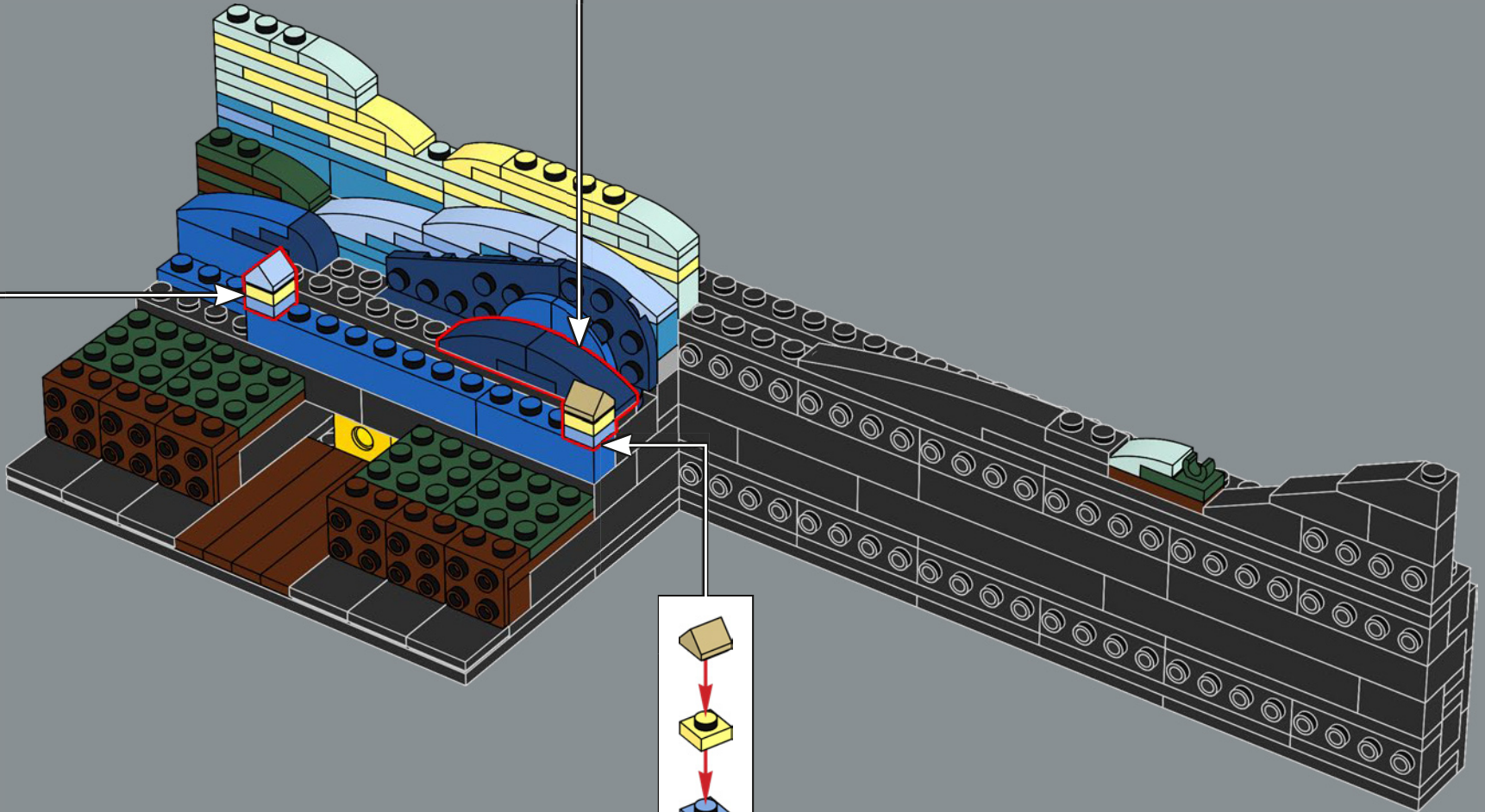
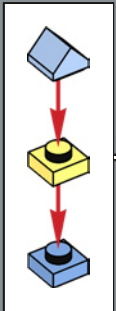
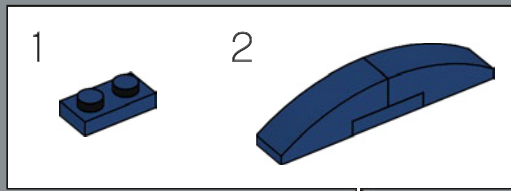

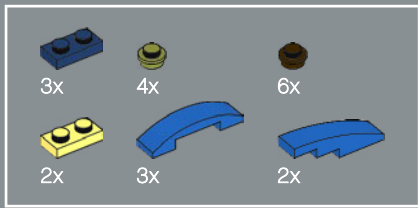

31

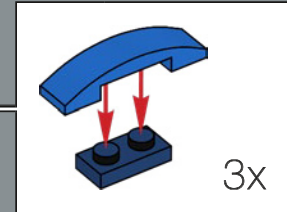
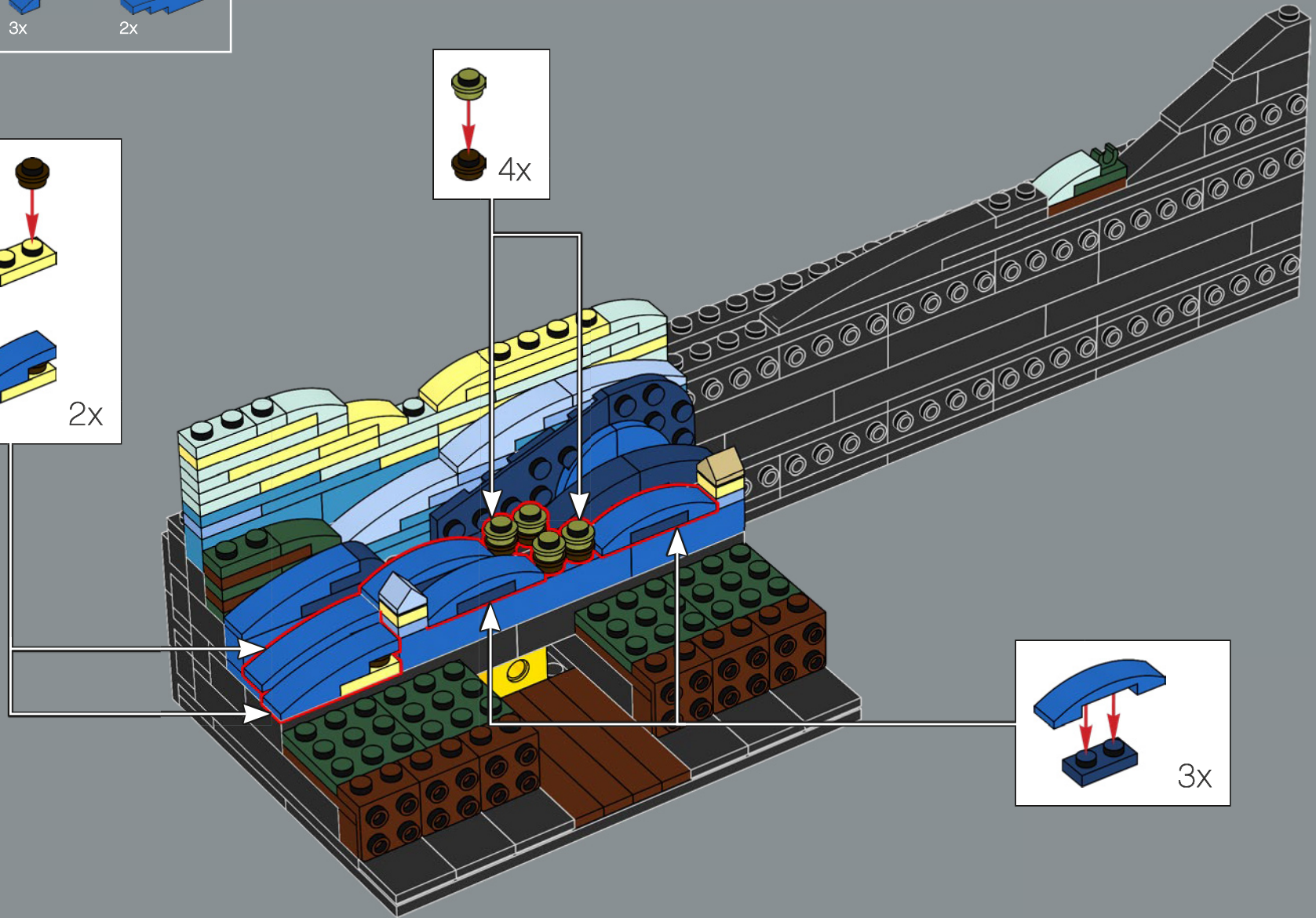
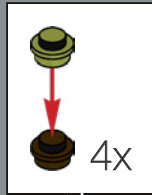
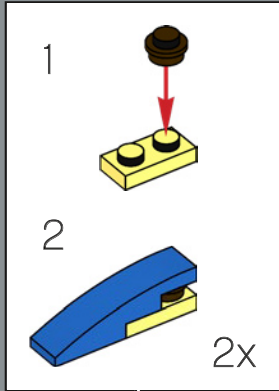

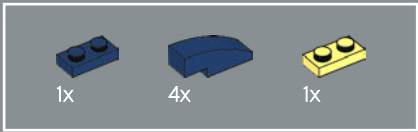

32

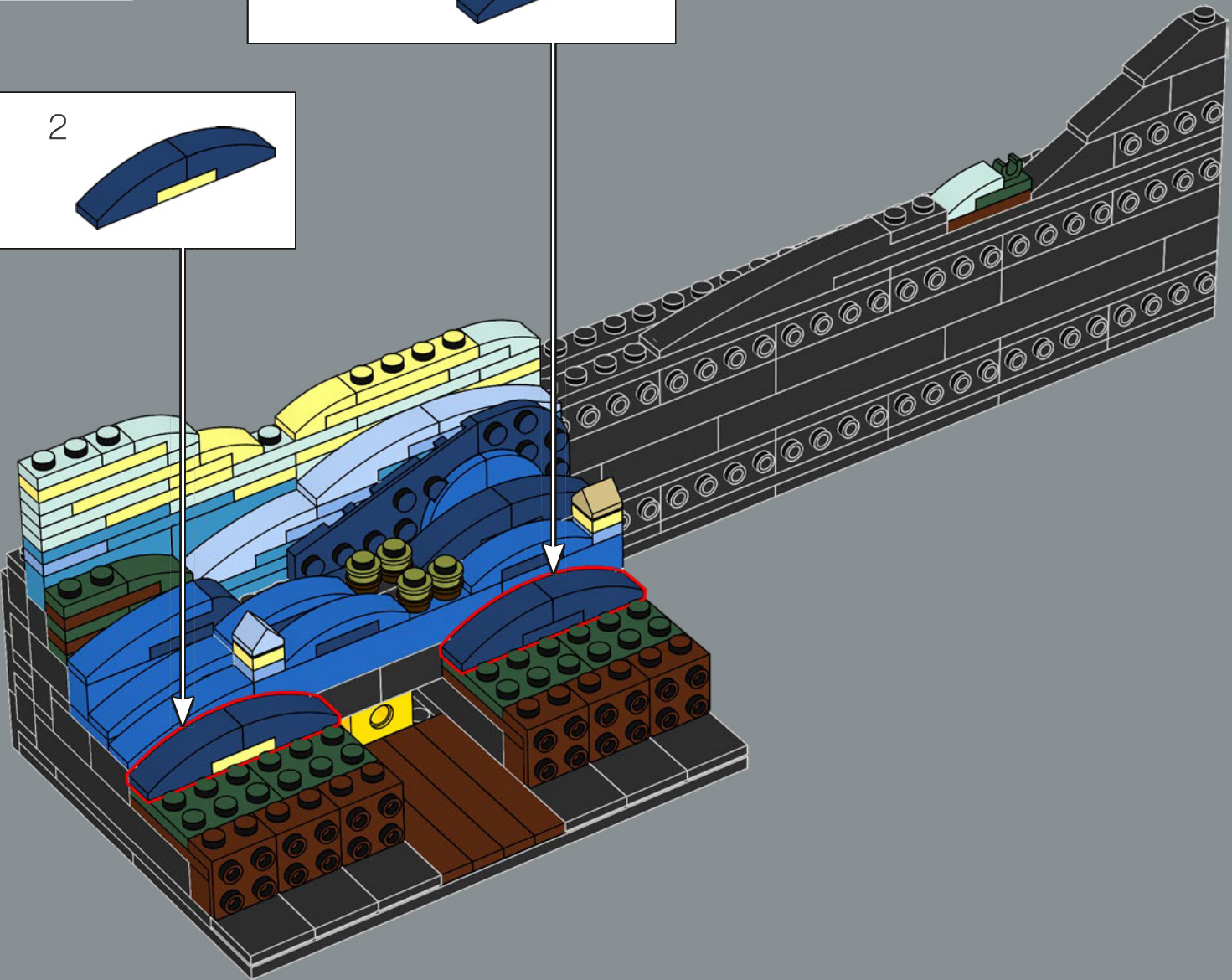
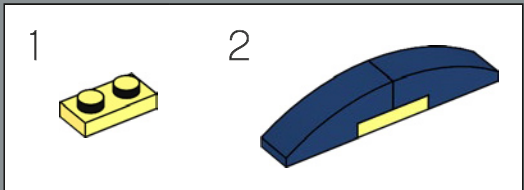
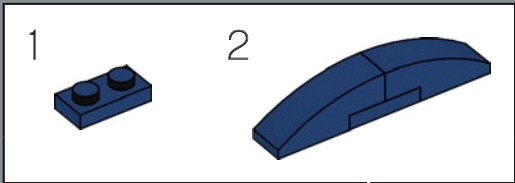

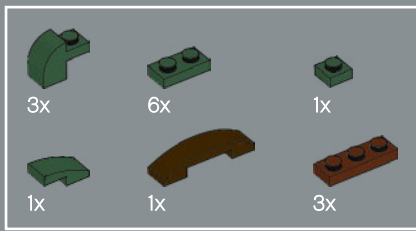

33

1

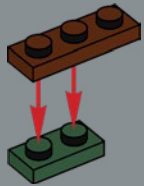

2

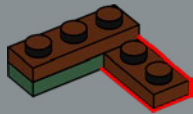

3

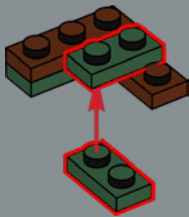

4

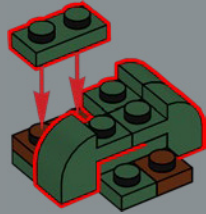

5

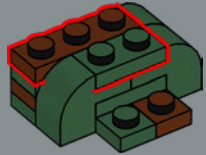

6

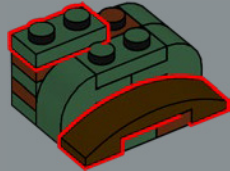

7

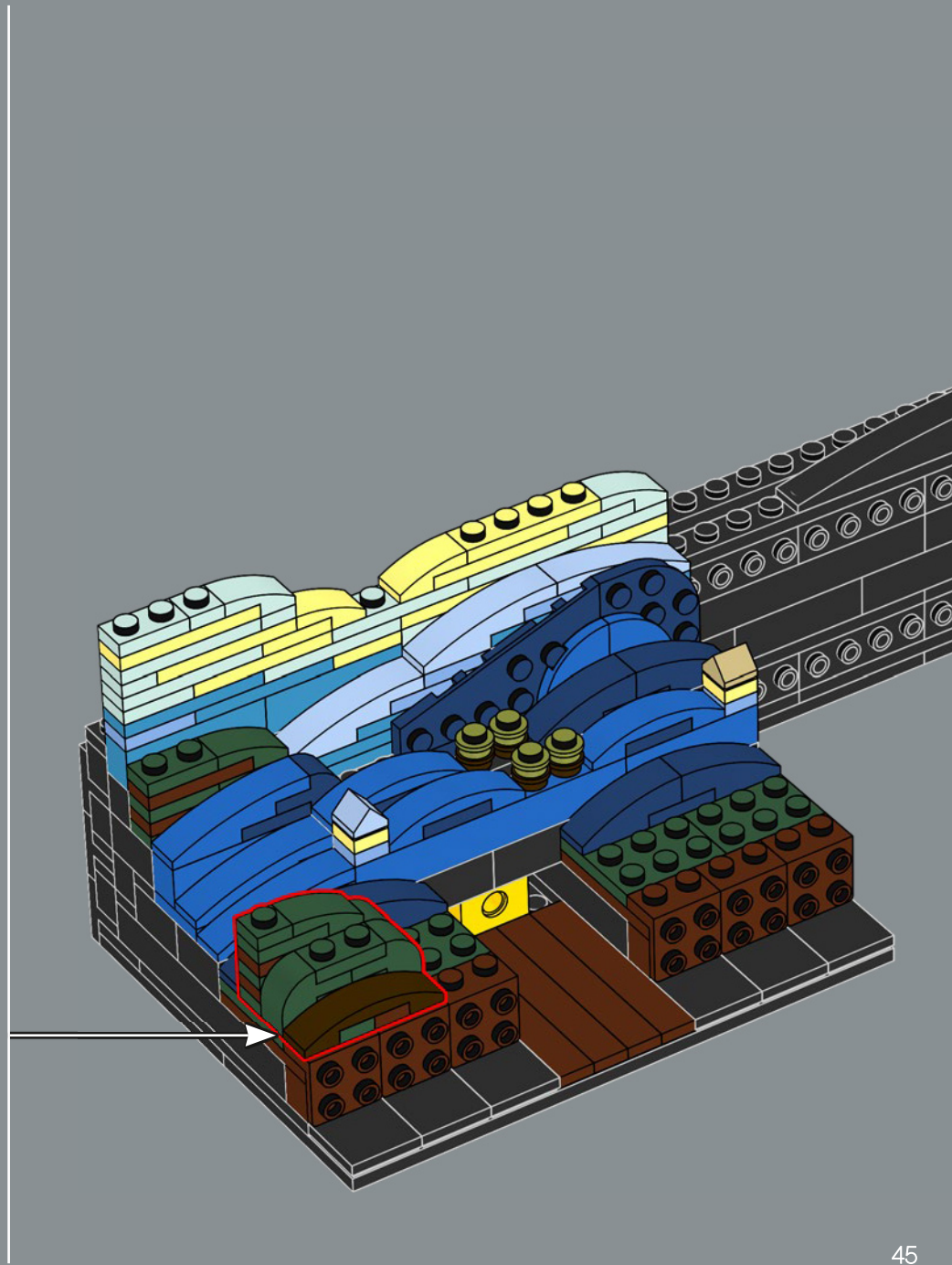
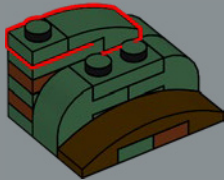

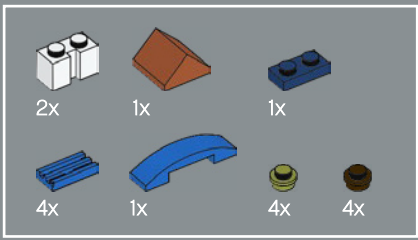

34

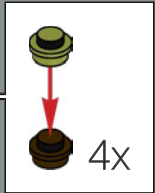
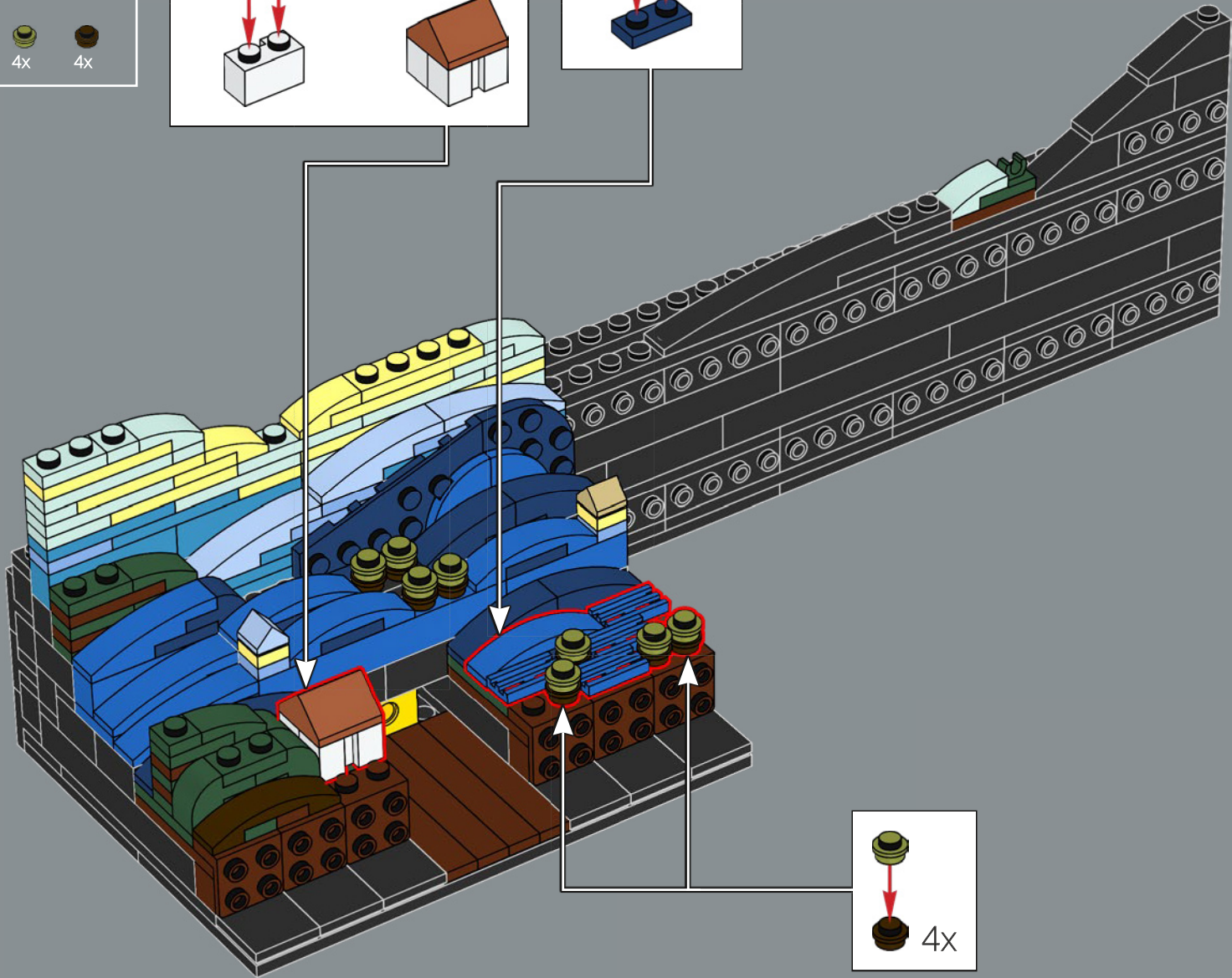
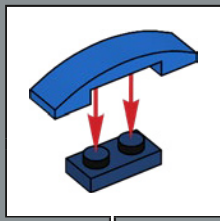
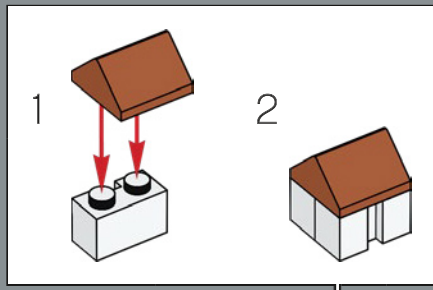



35

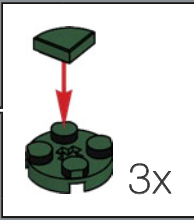
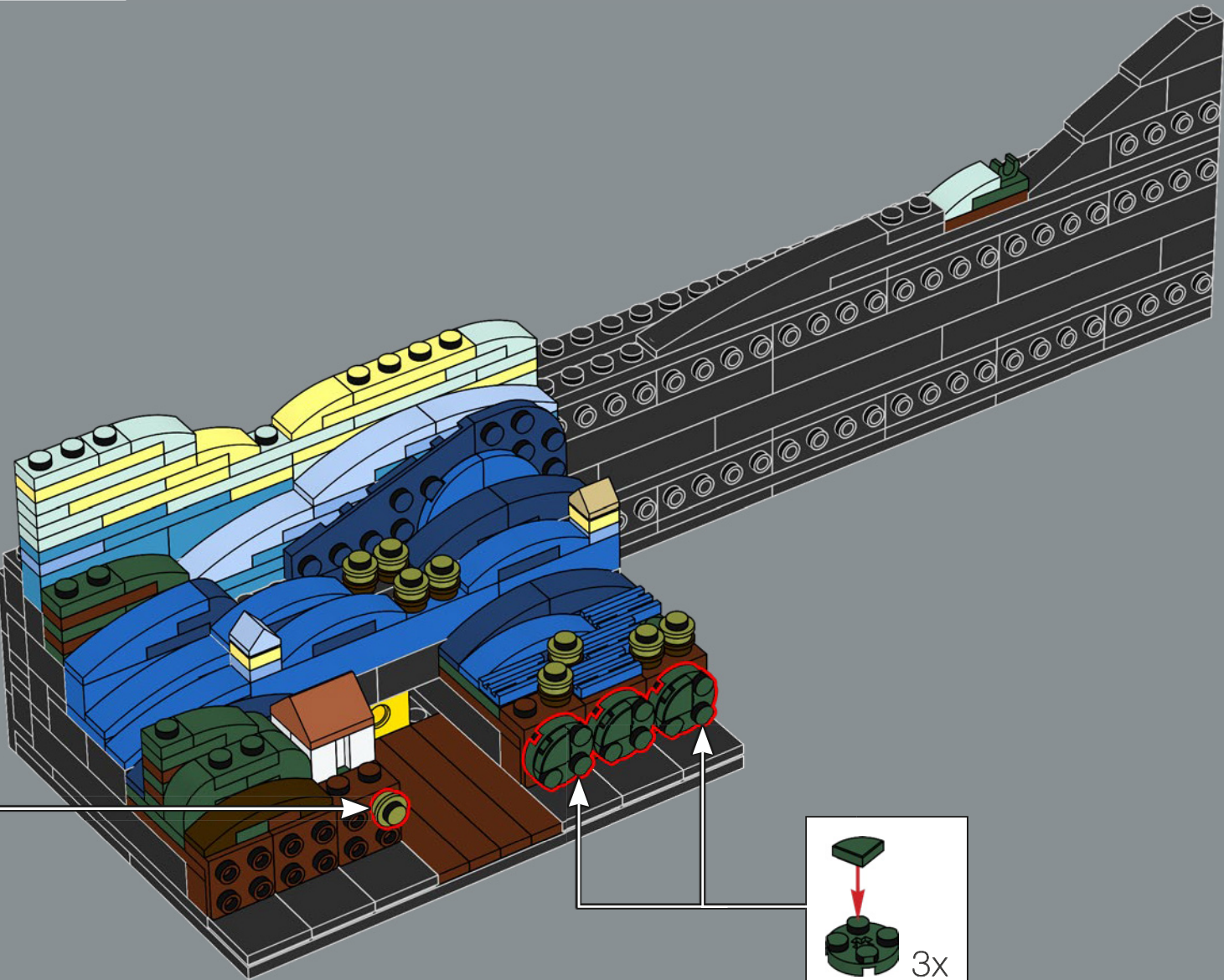

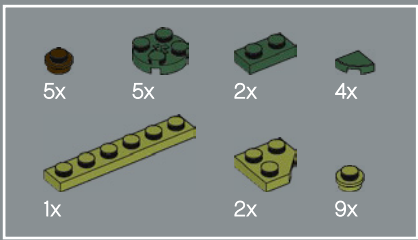

36

1

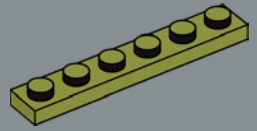

2

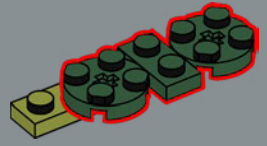

3

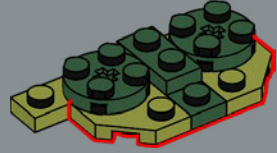

4

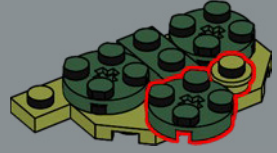

5

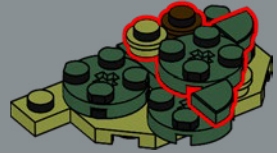

6



7

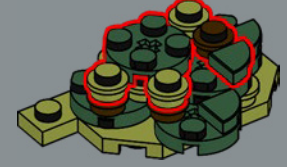

8

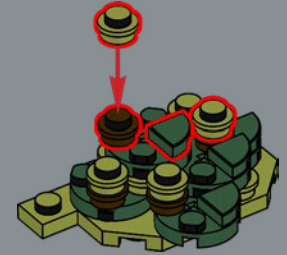

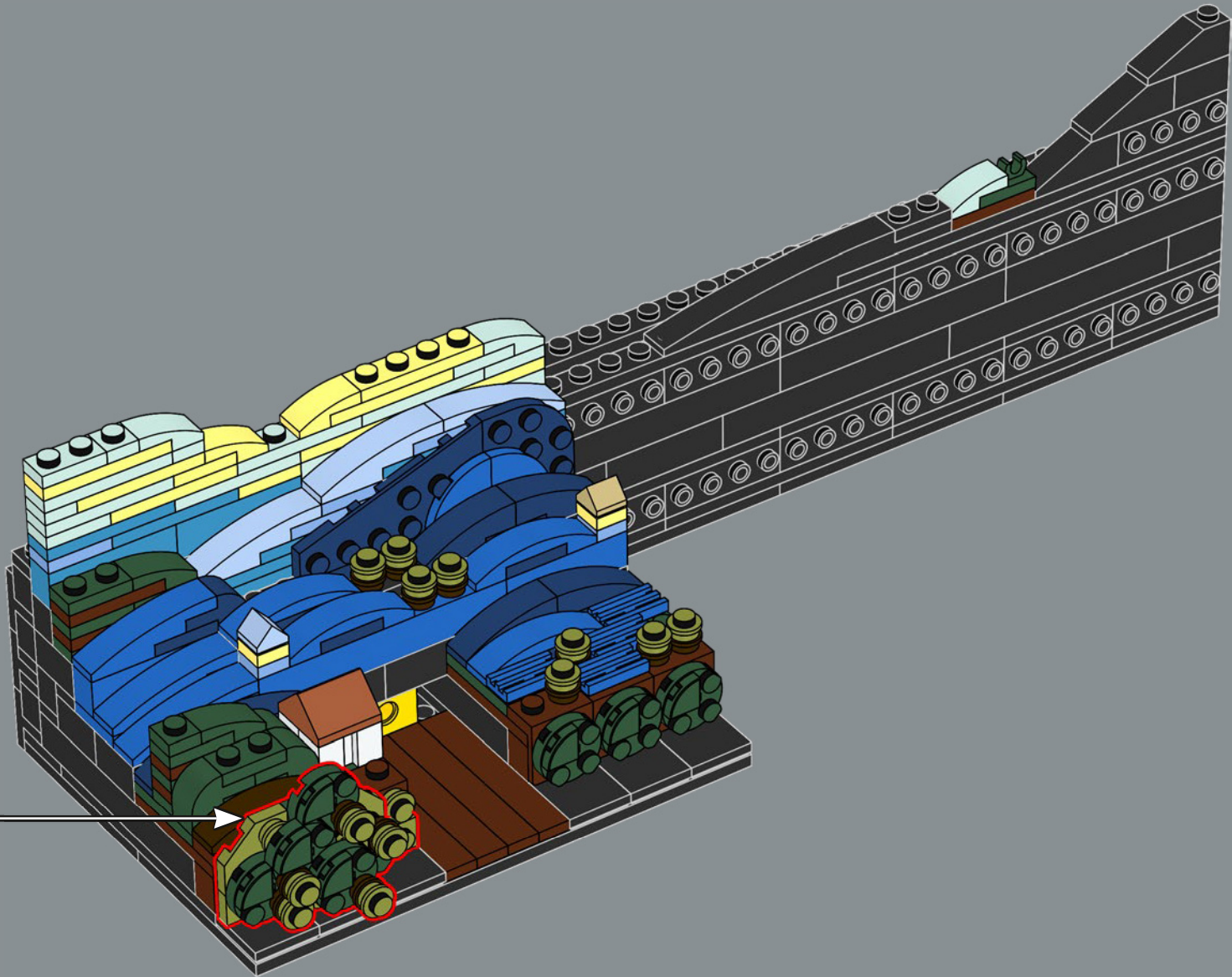

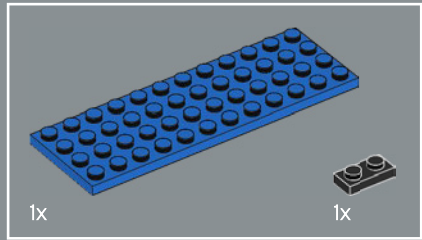
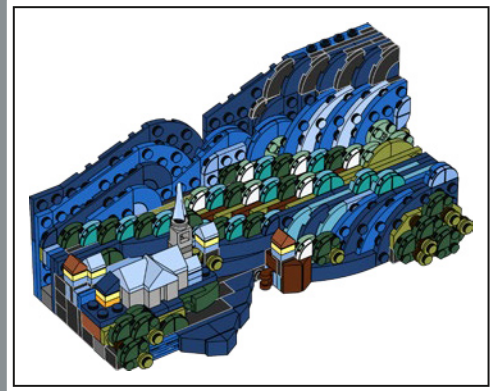

37

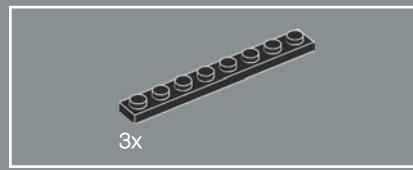
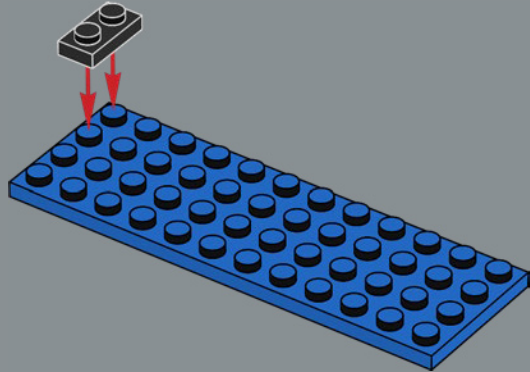

38

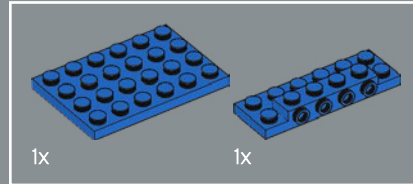
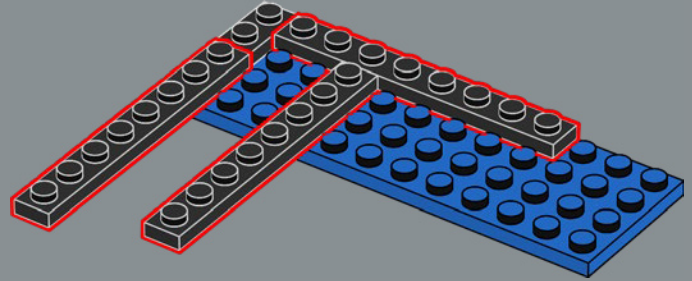

39

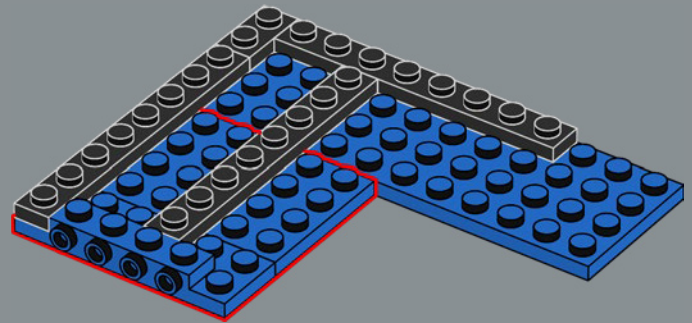

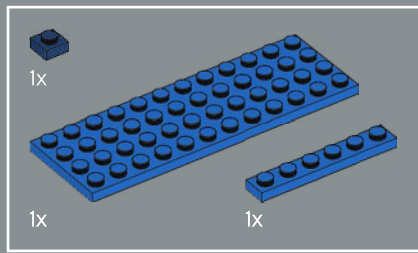

40

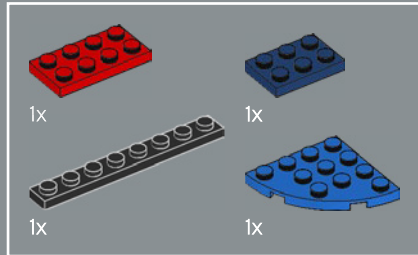
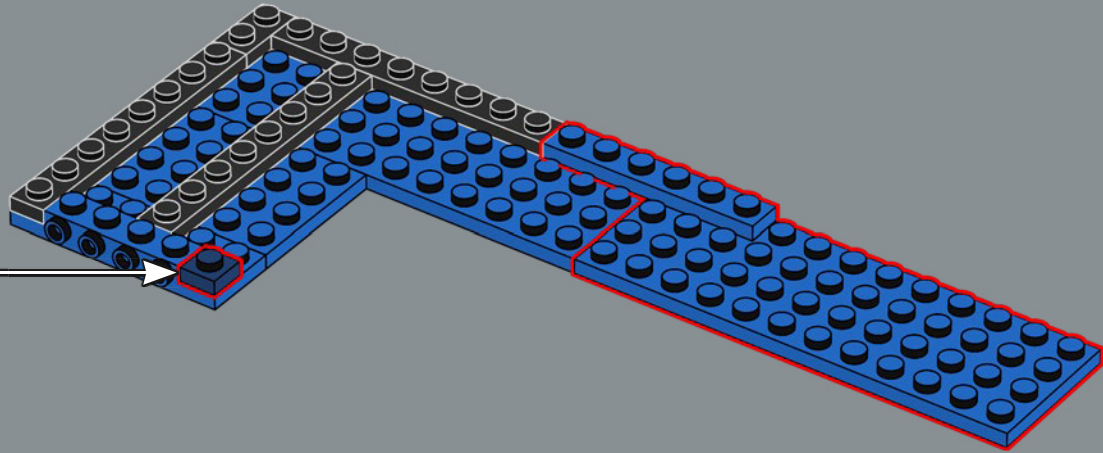

41

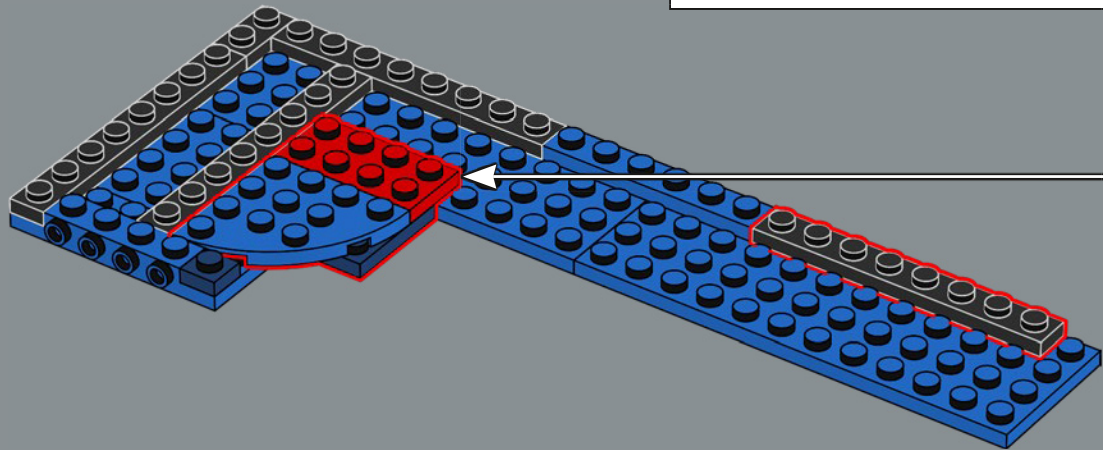
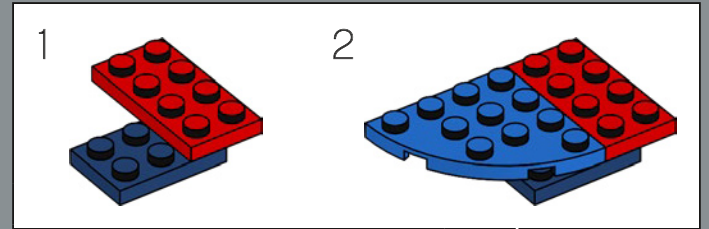

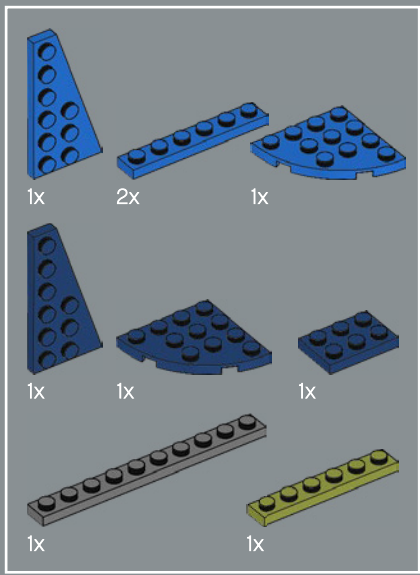

42

1

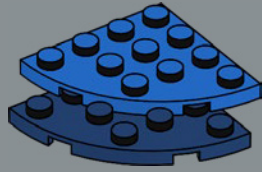

2

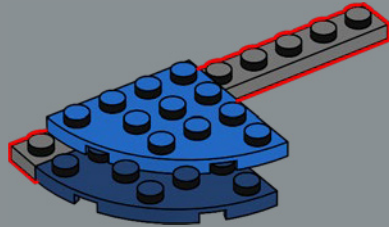

3

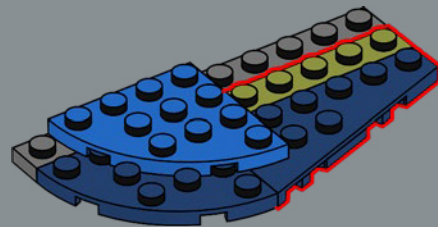

4

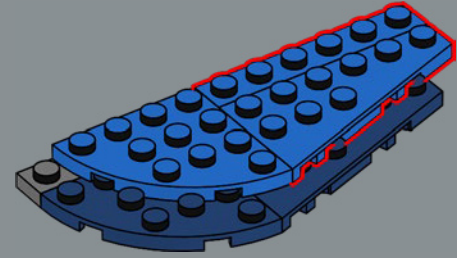

5

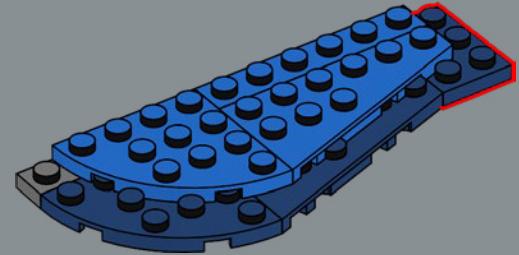

6

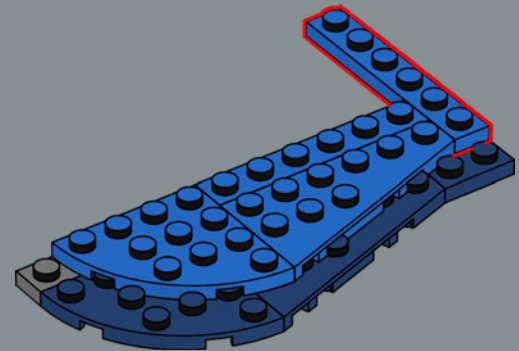

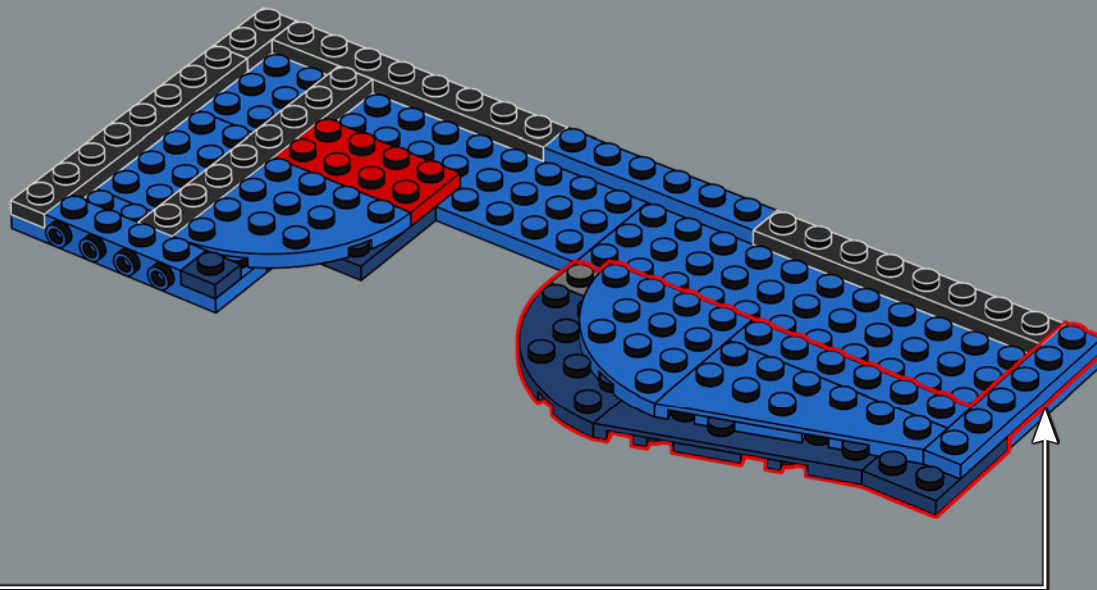

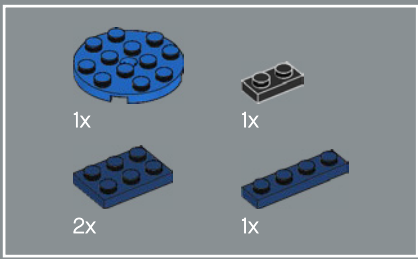

43

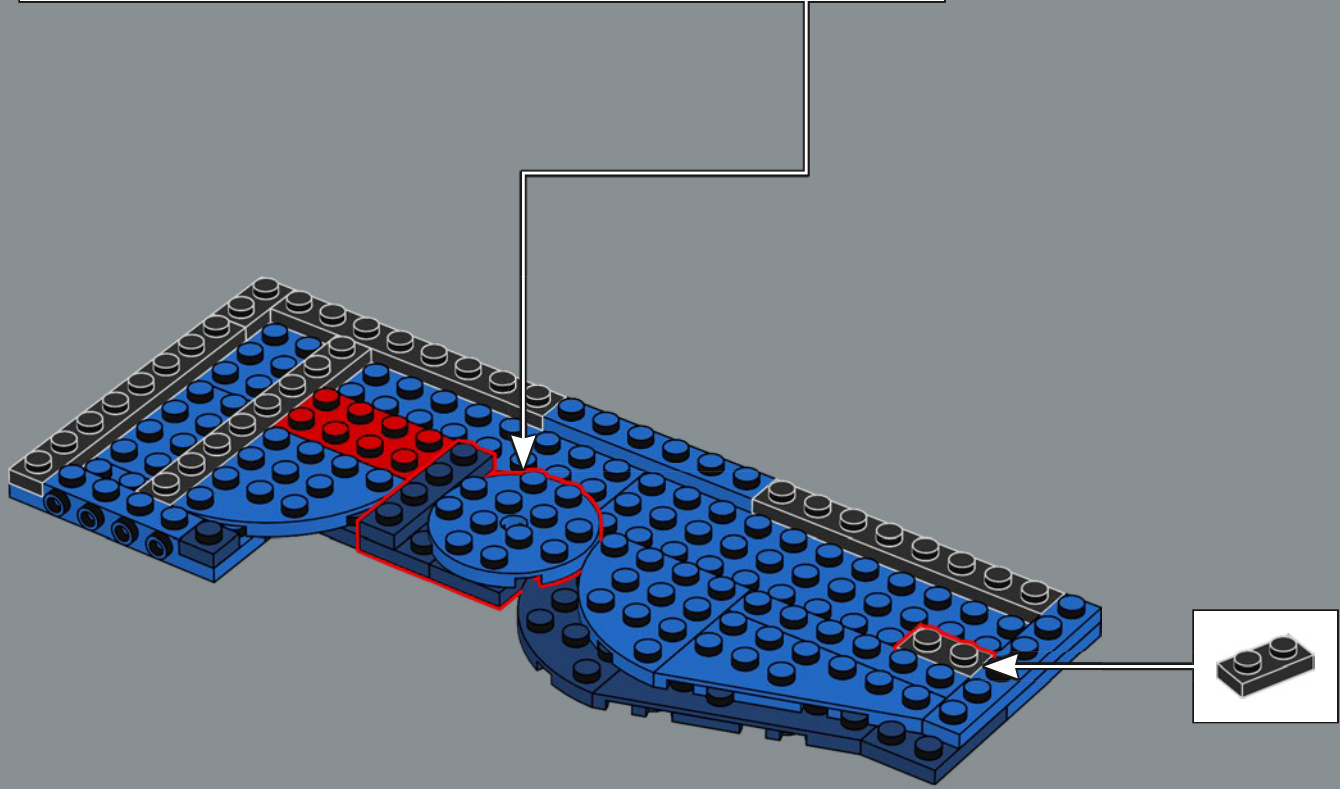
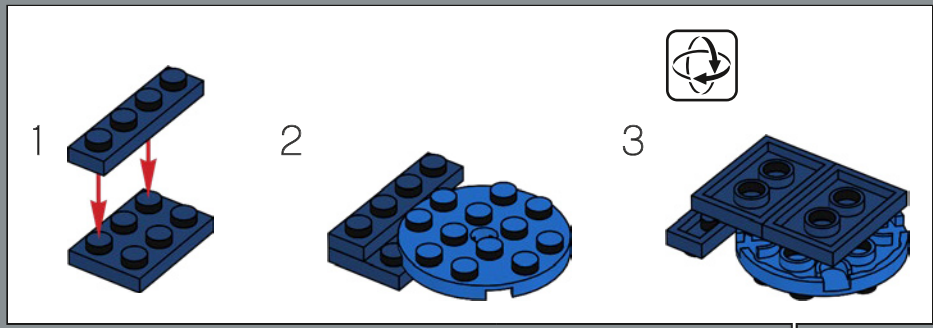

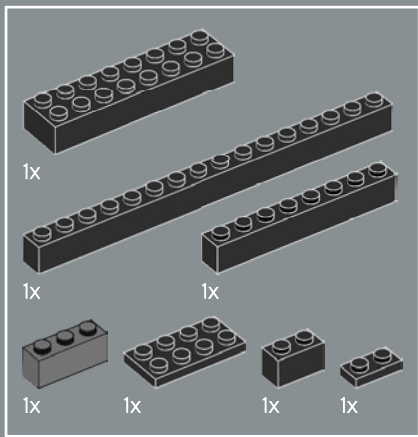

44

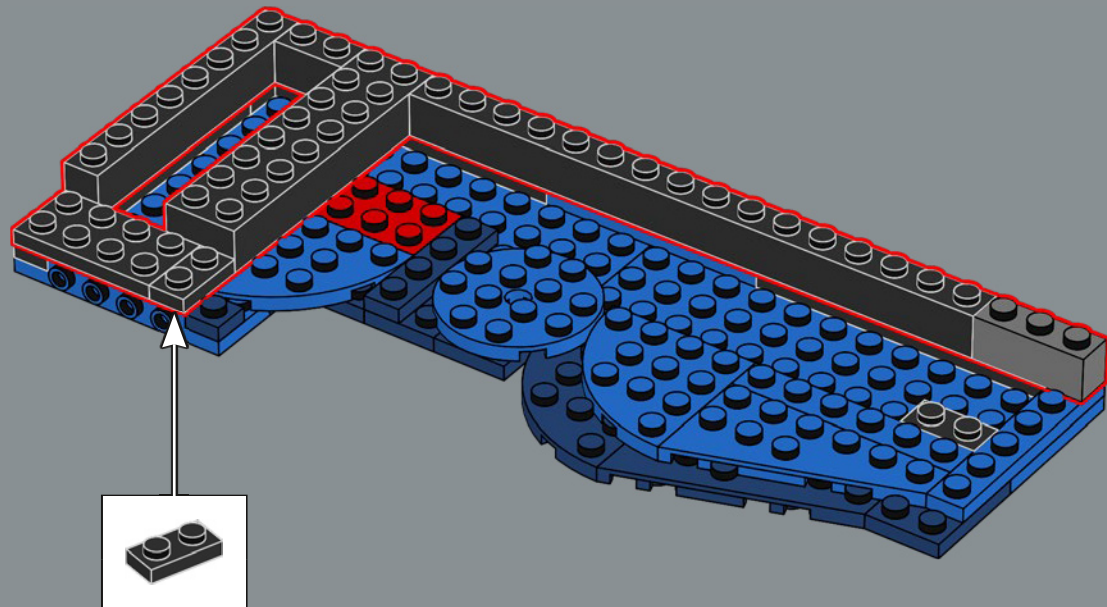

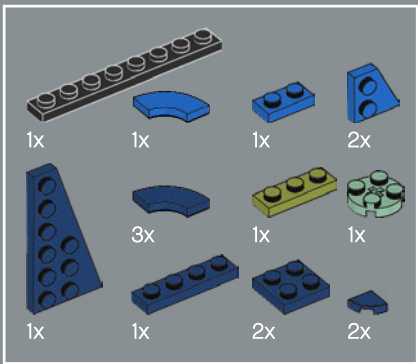

45

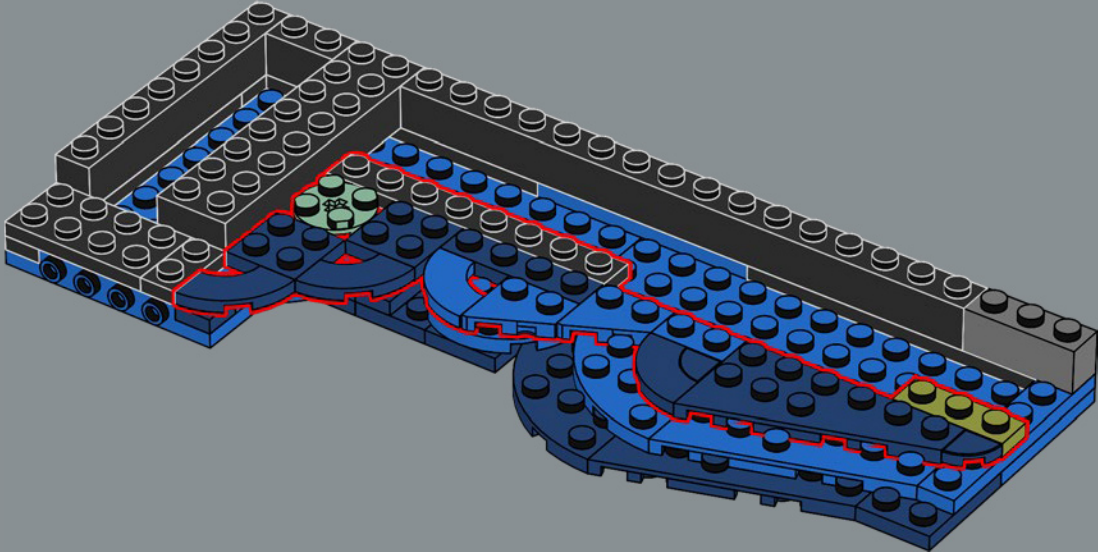

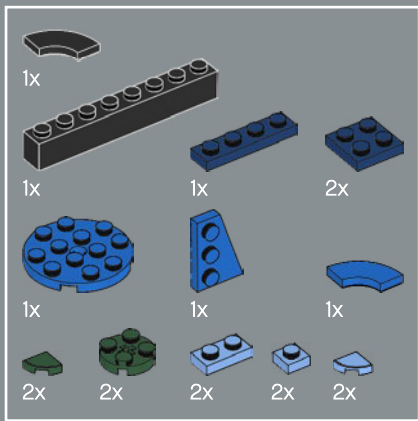

46

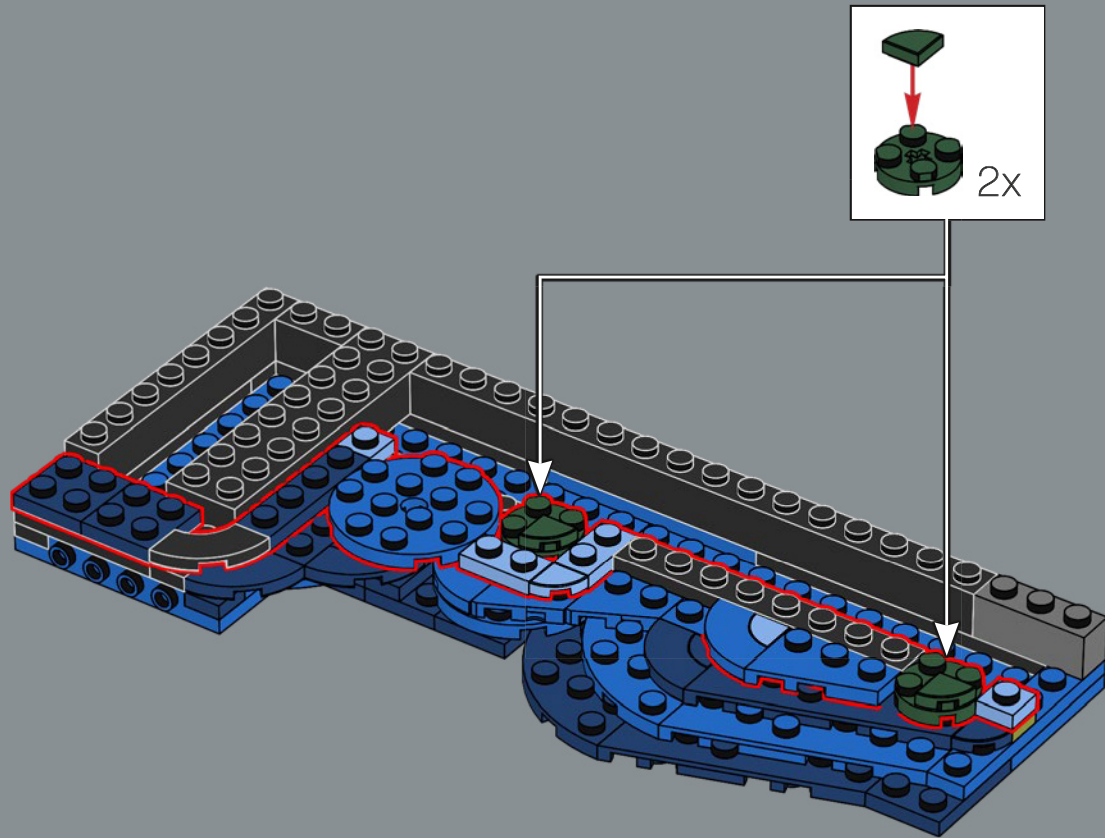

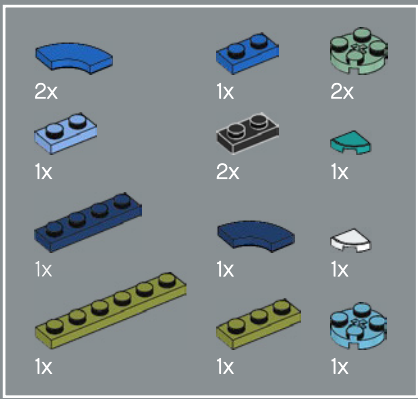

47

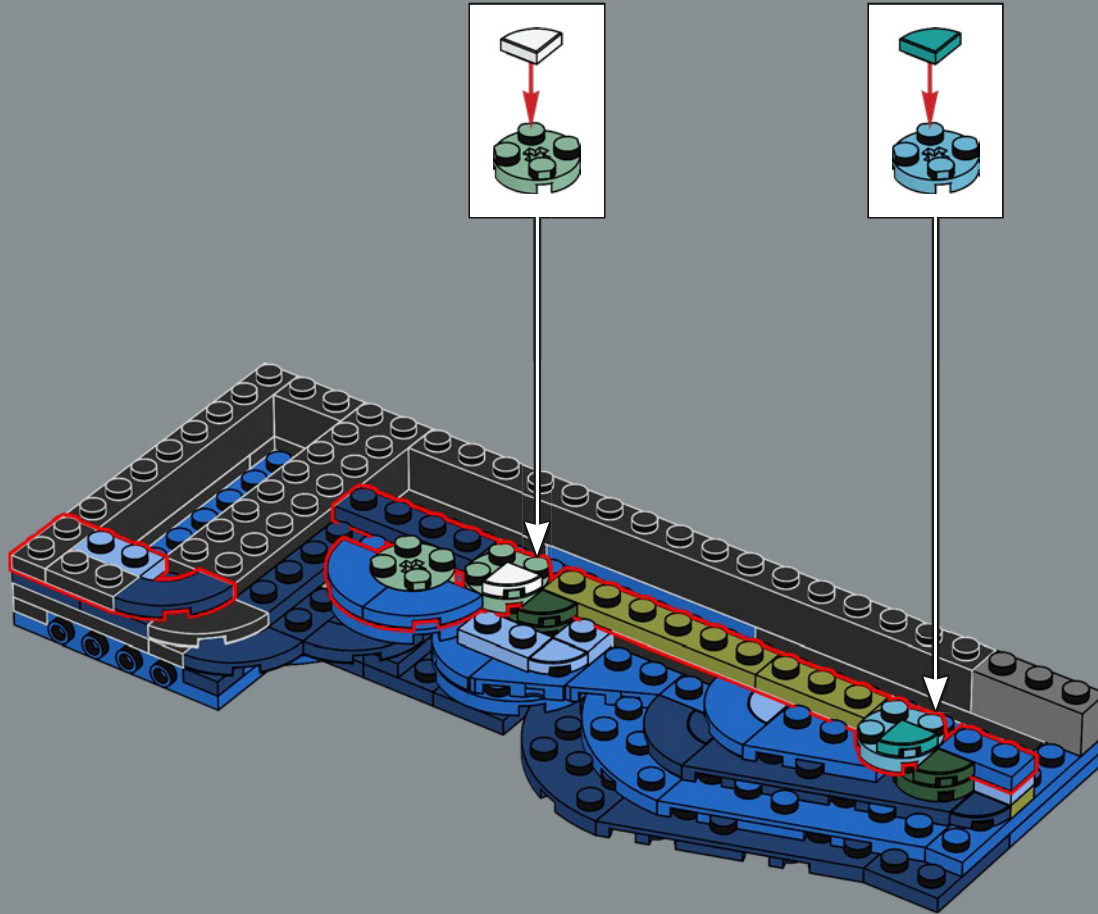

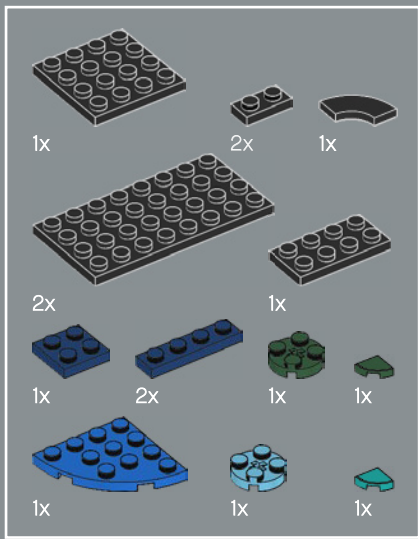

48

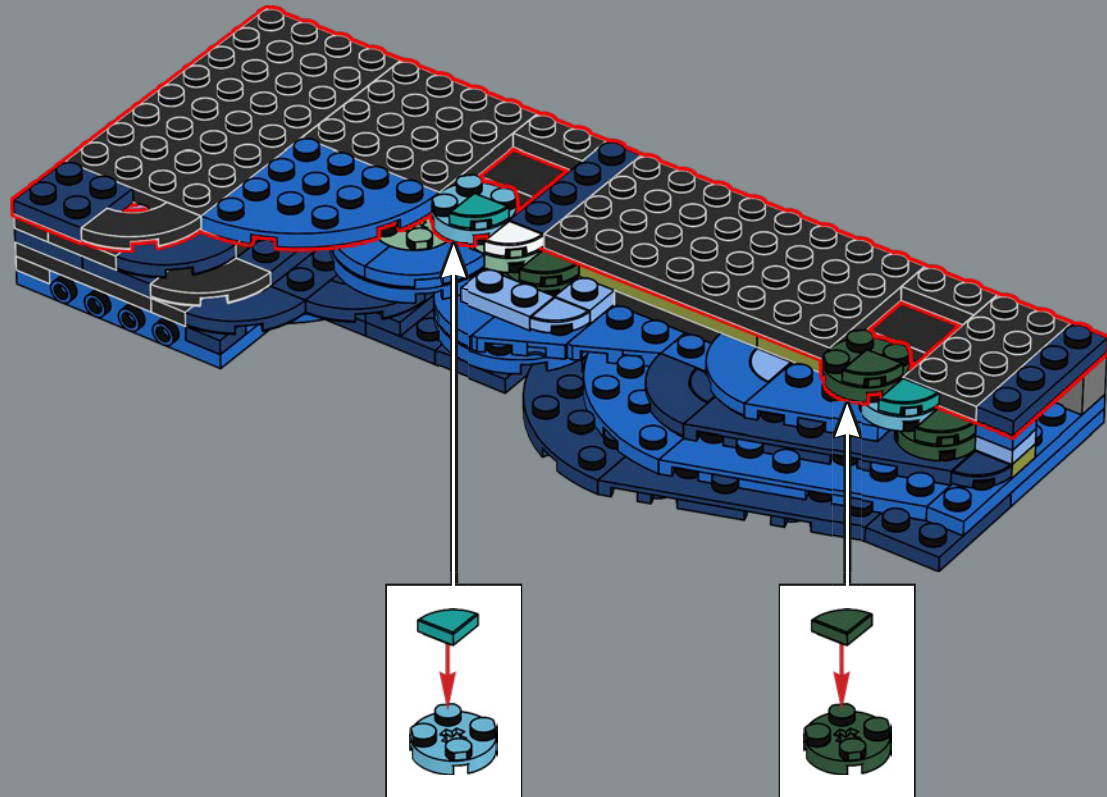

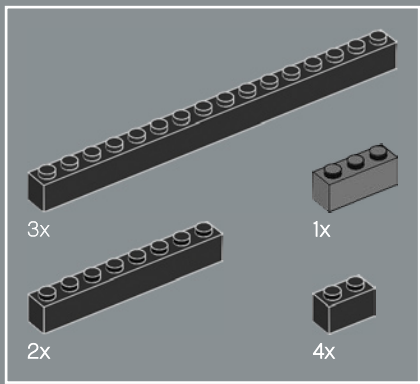

49

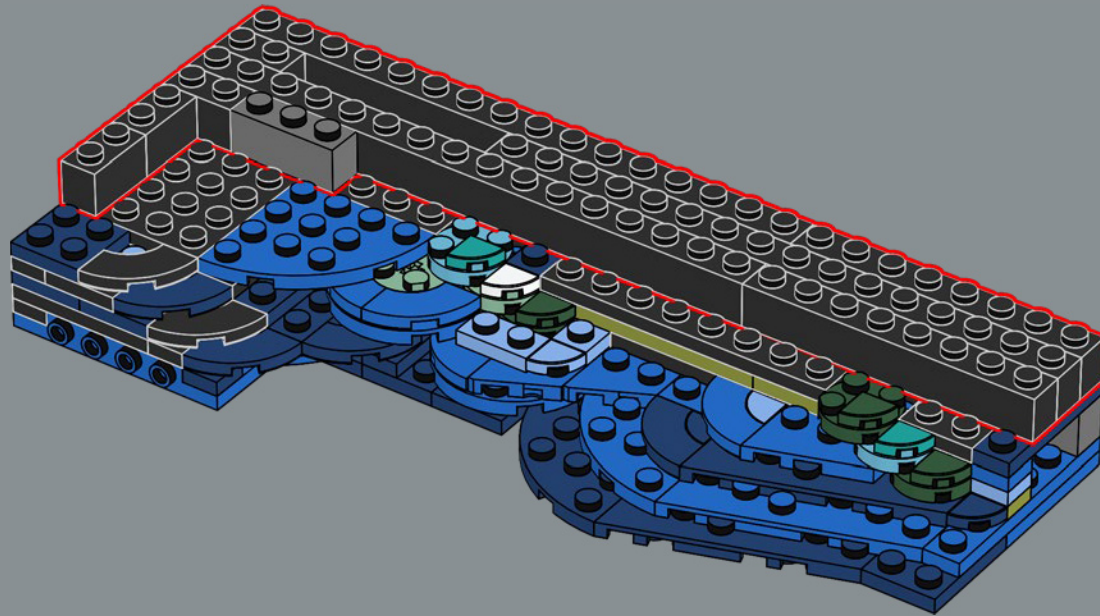

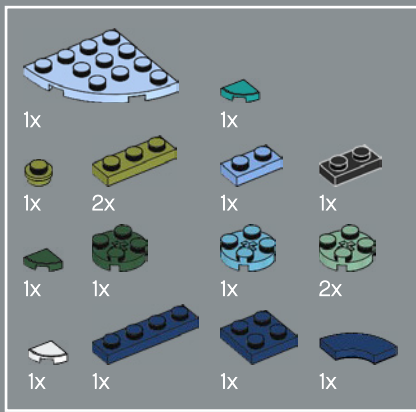

50

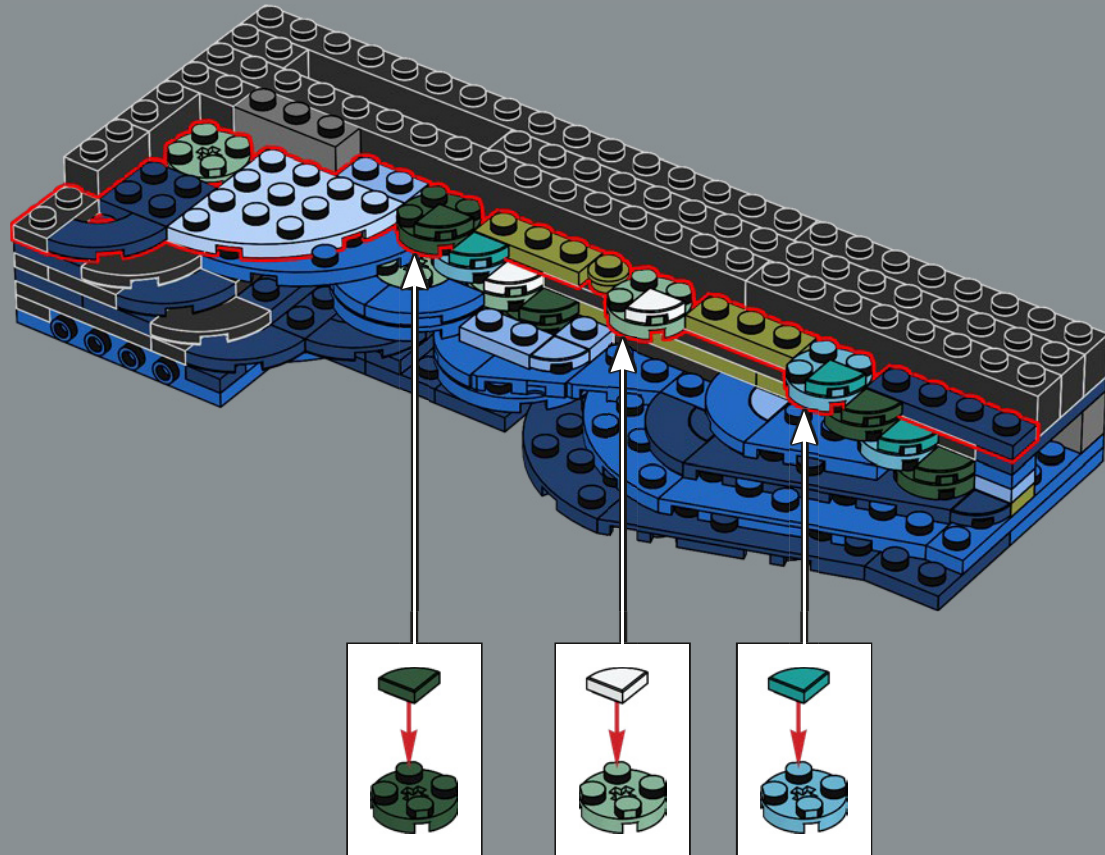

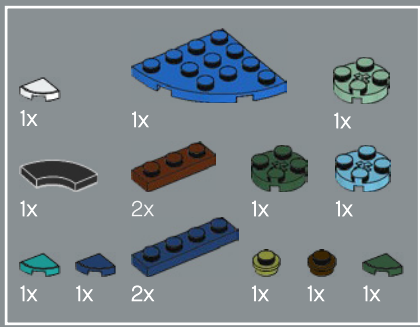

51

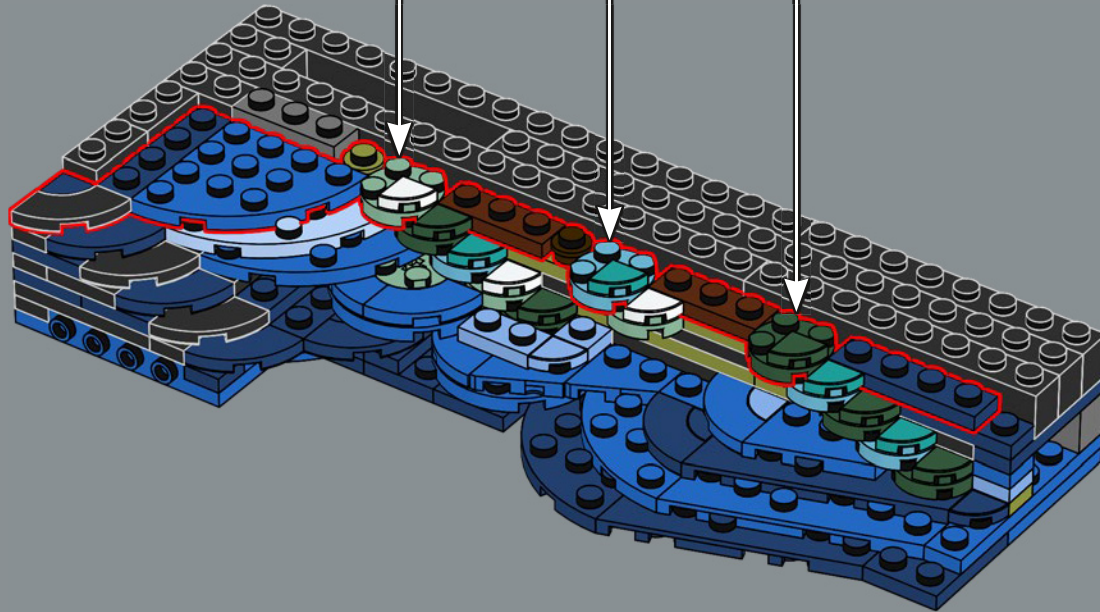
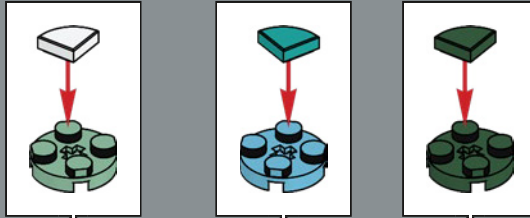

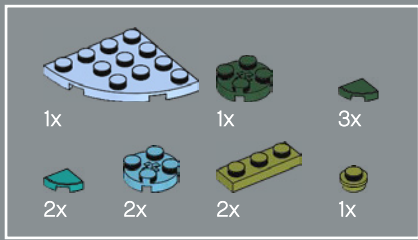

52

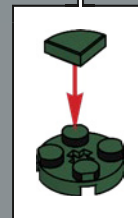
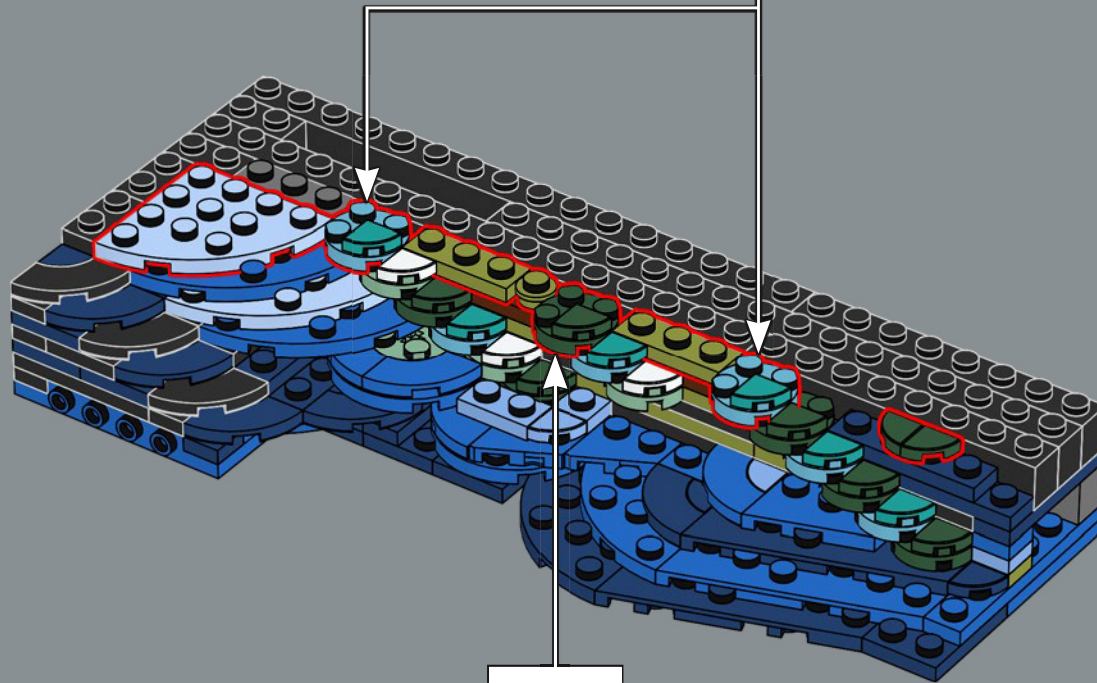
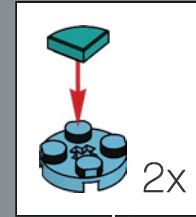

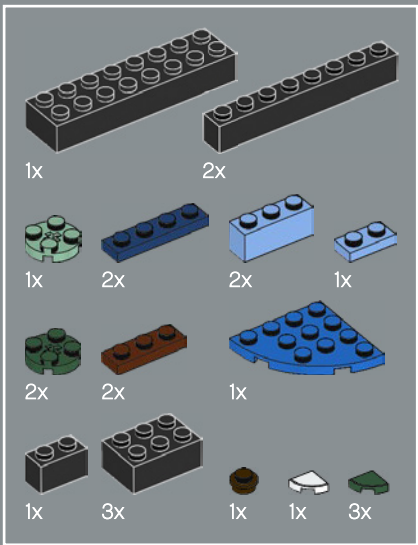

53

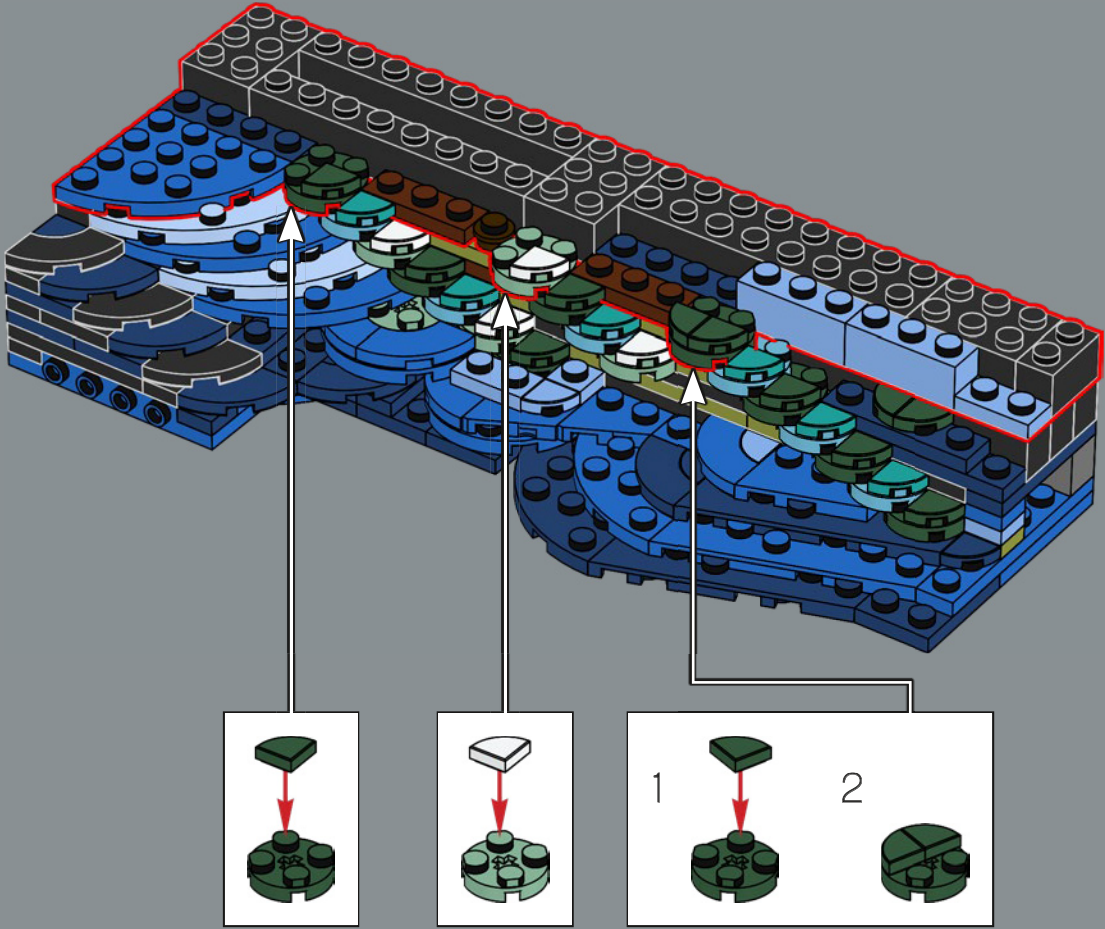

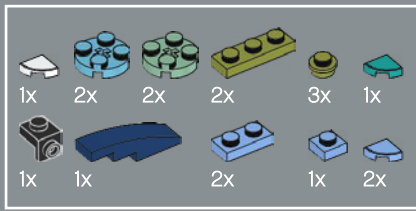

54

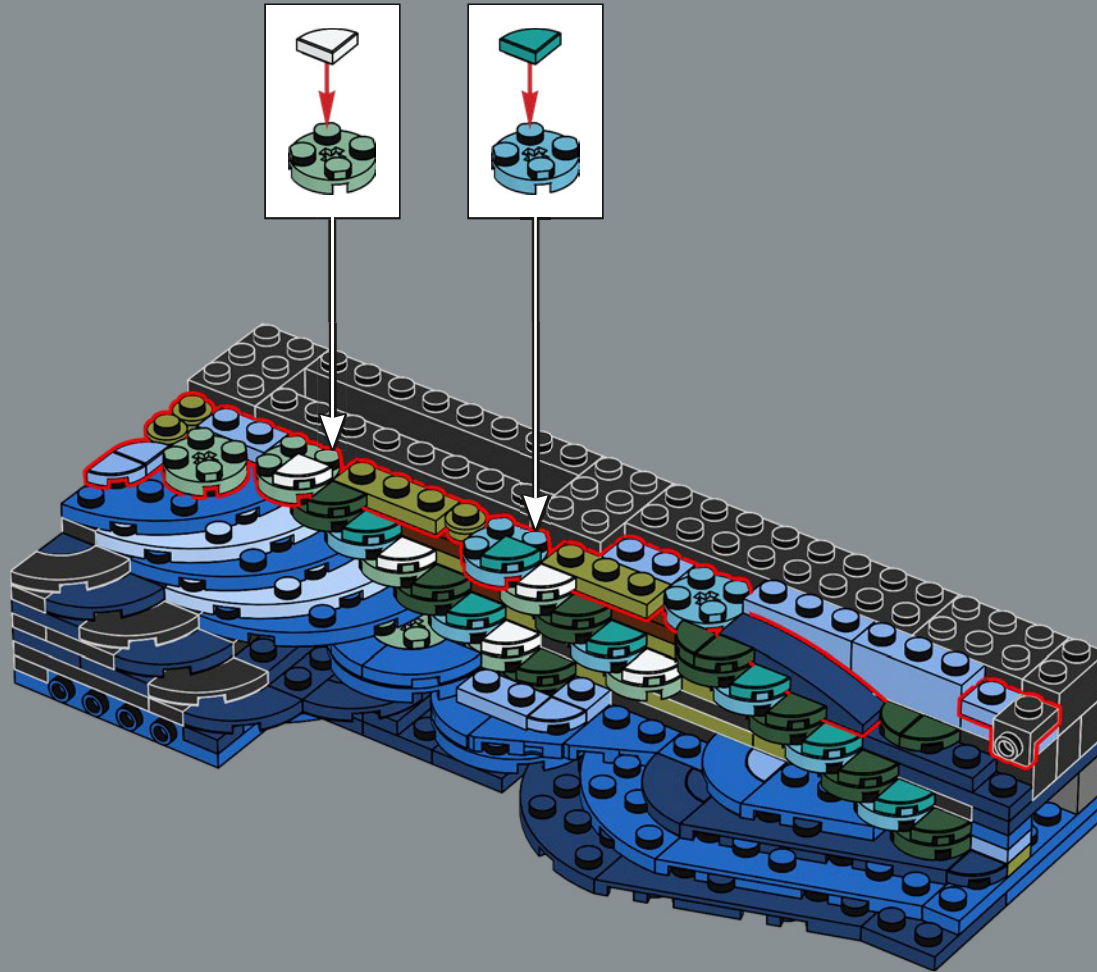

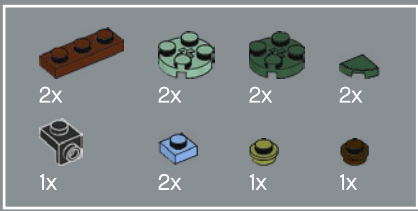

55

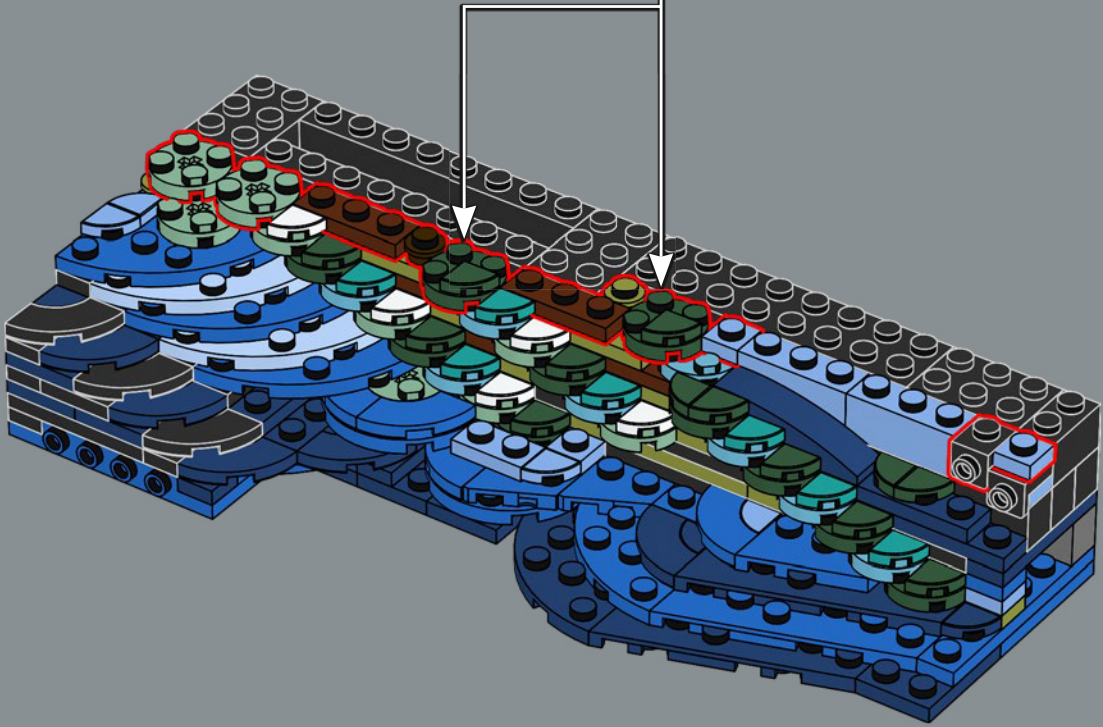
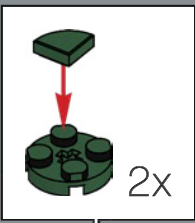

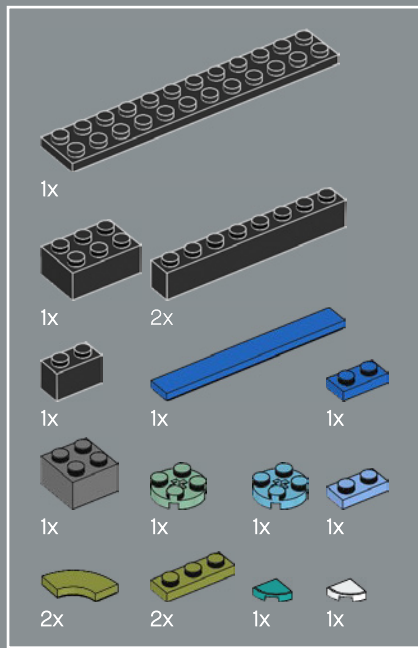

56

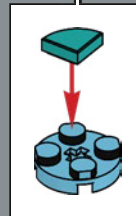
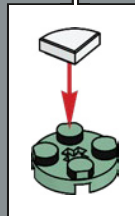
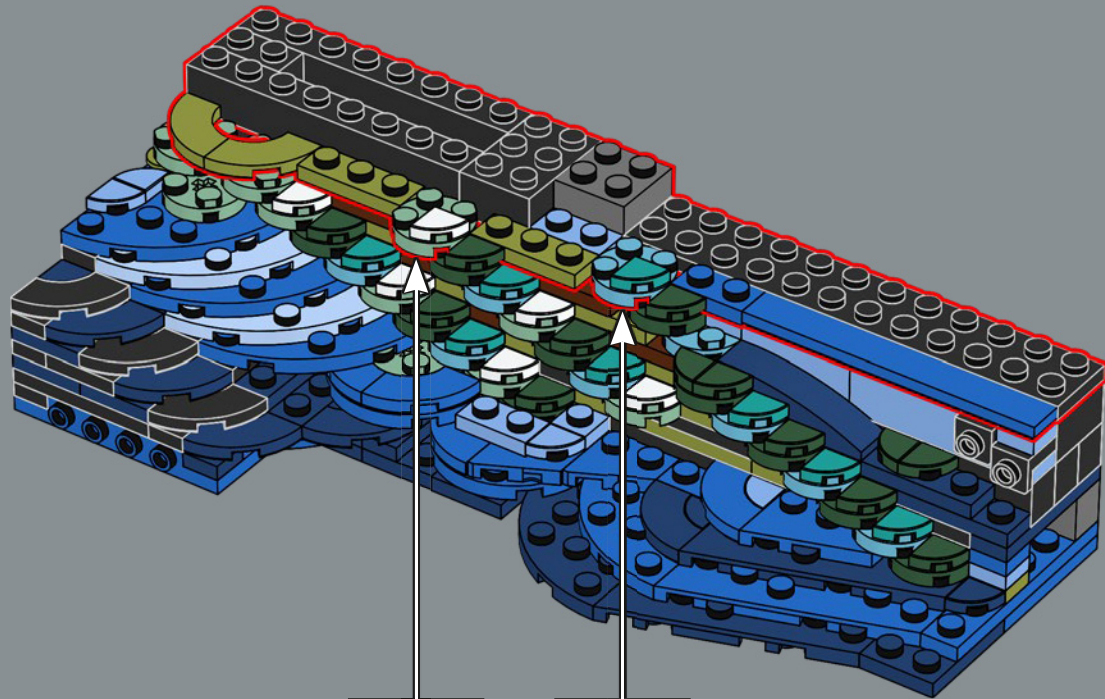

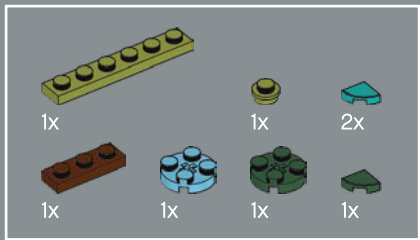

57

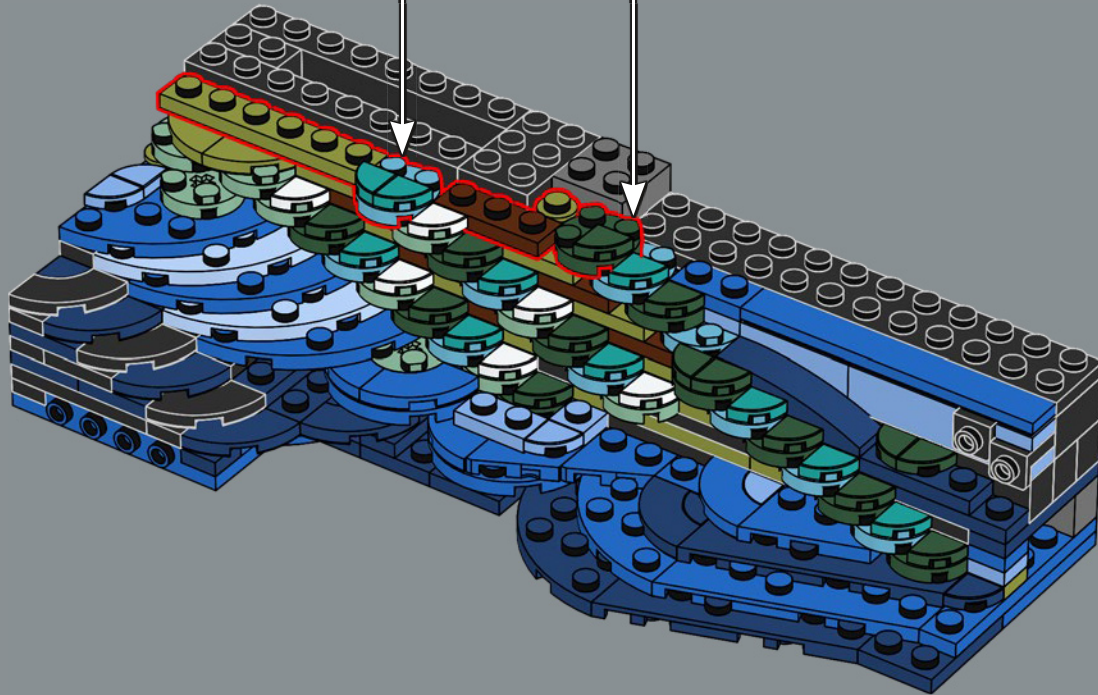
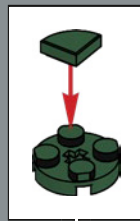
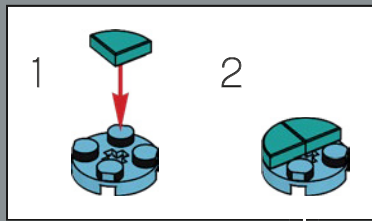

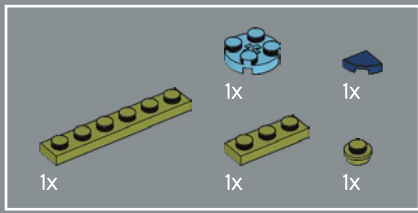

58

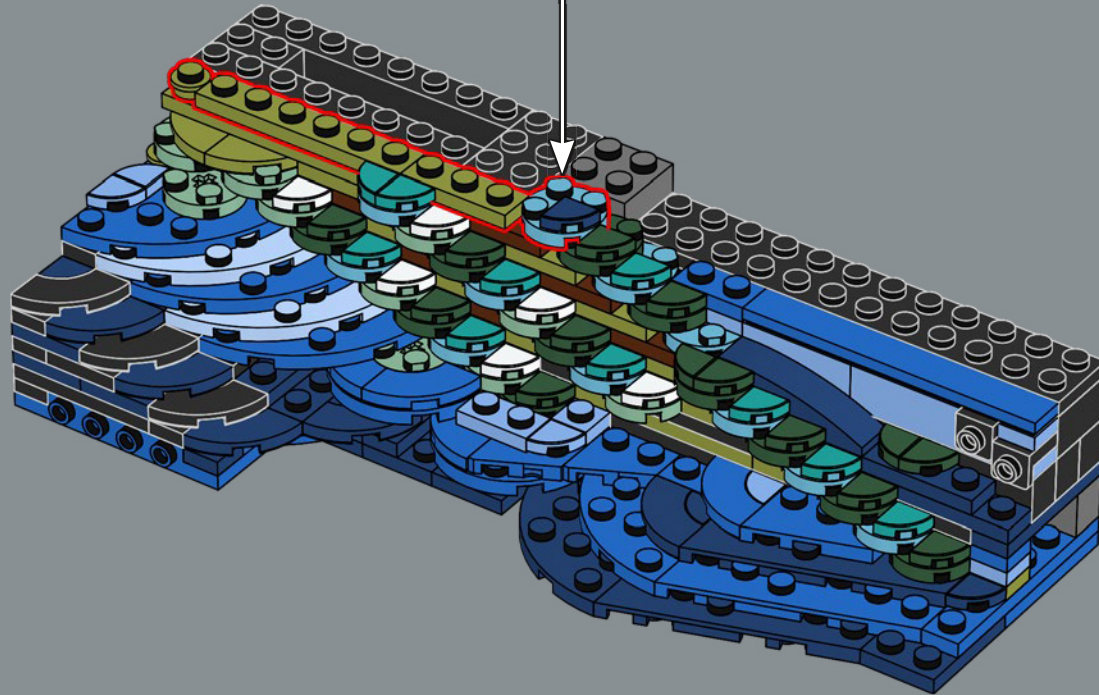
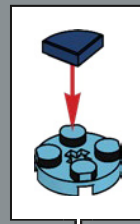

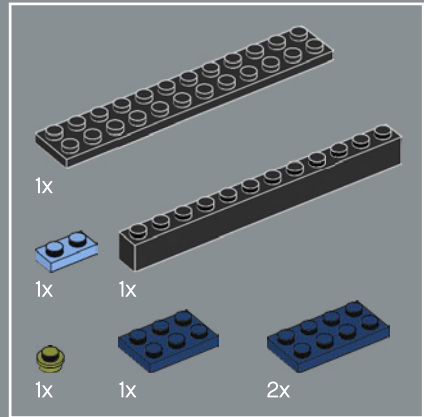

59

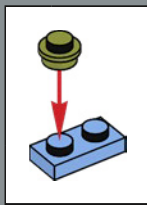
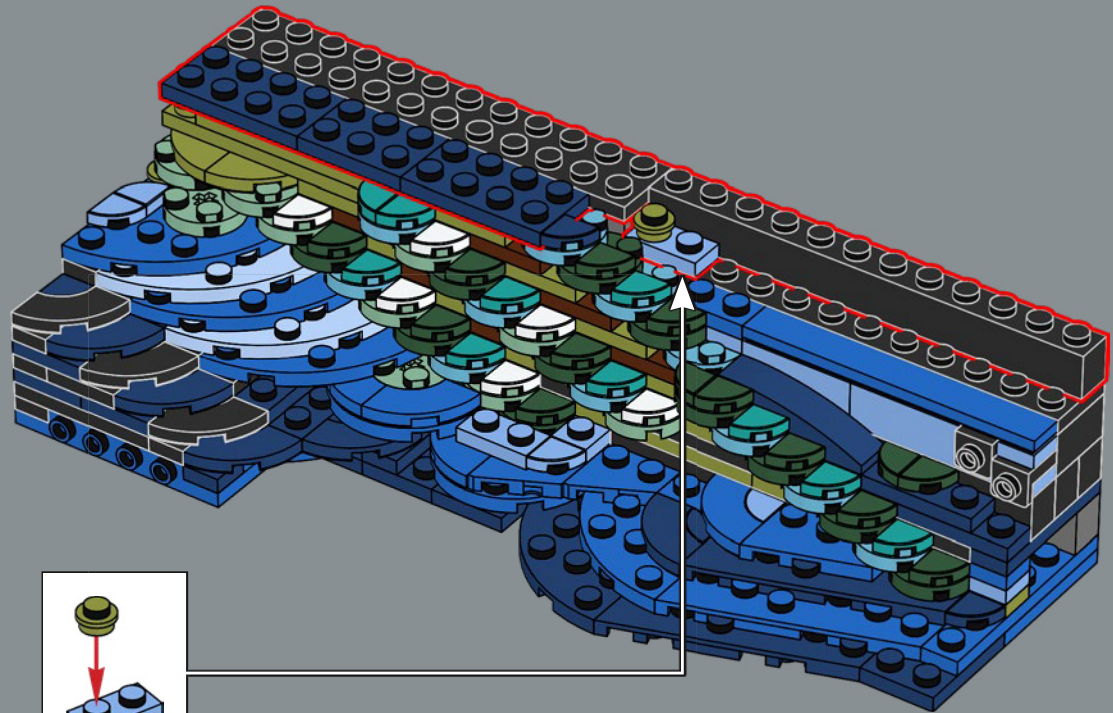

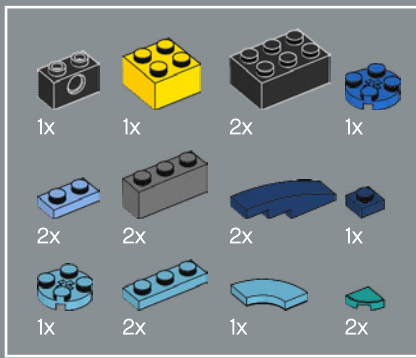

60

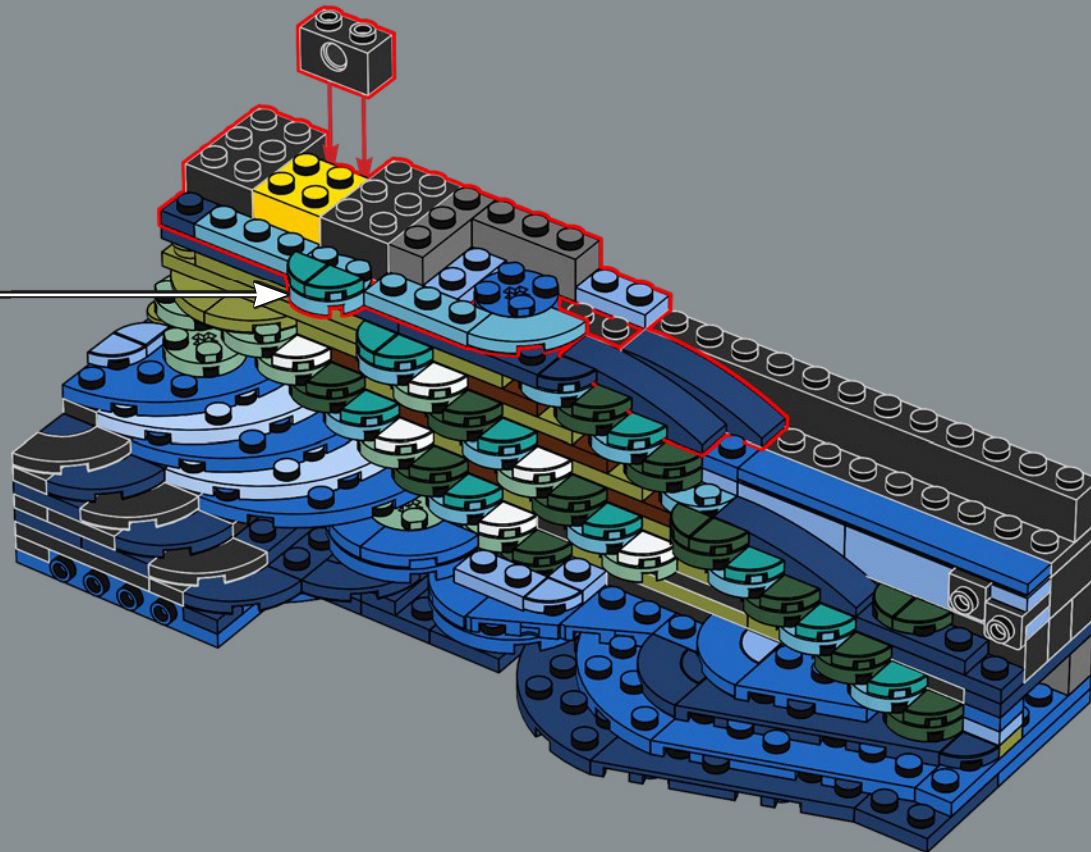
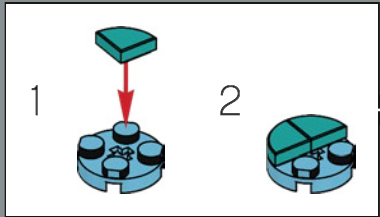

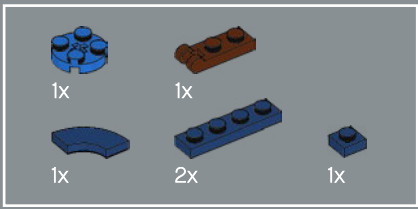

61

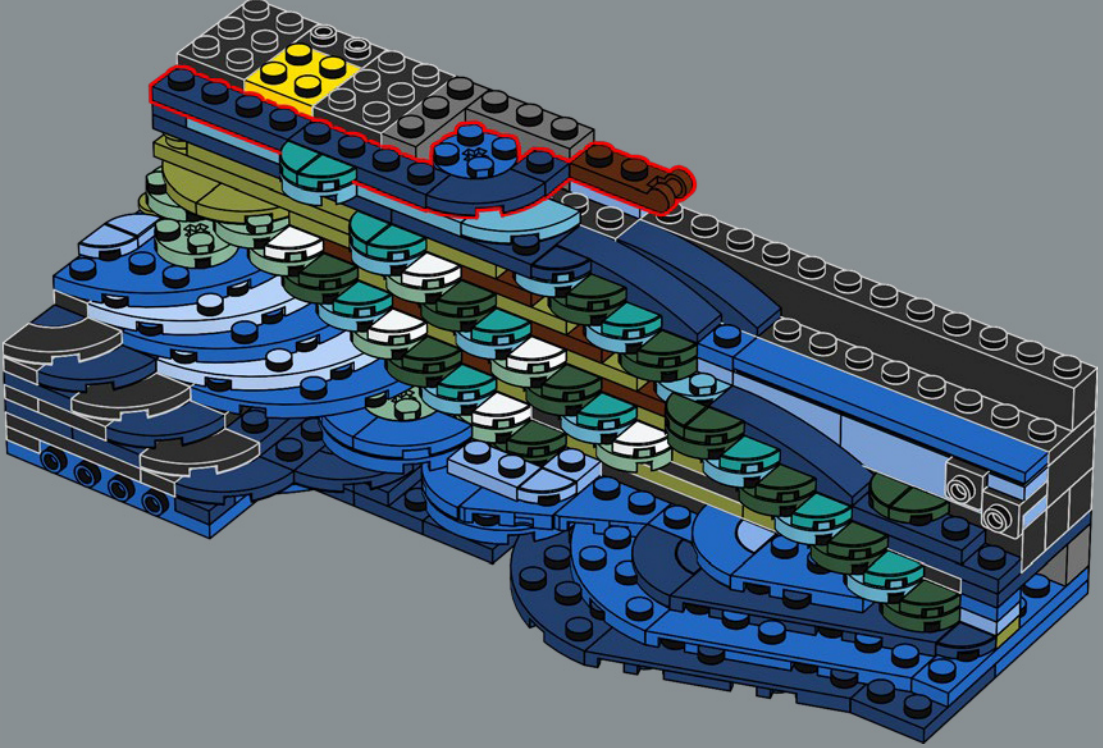

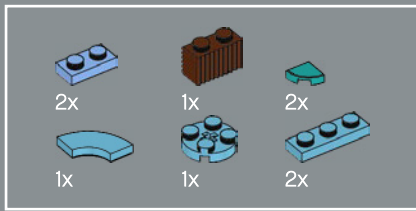

62

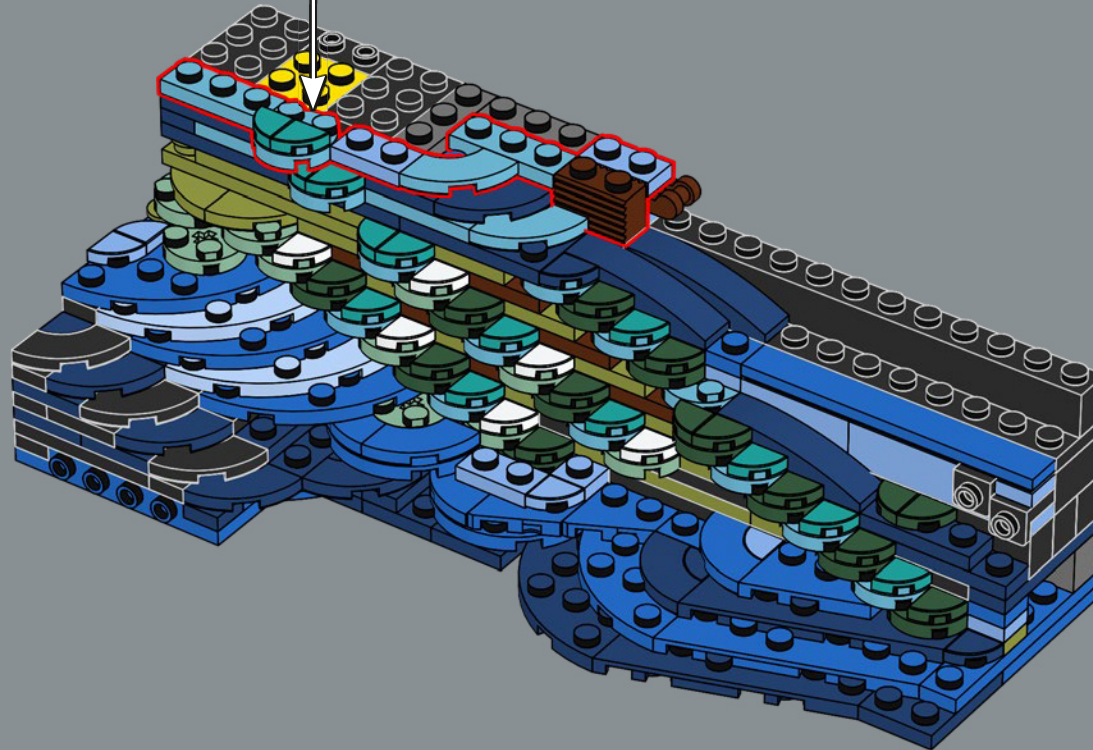
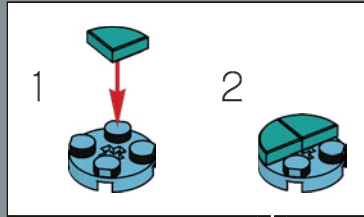

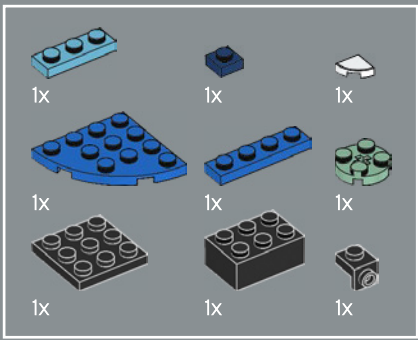

63

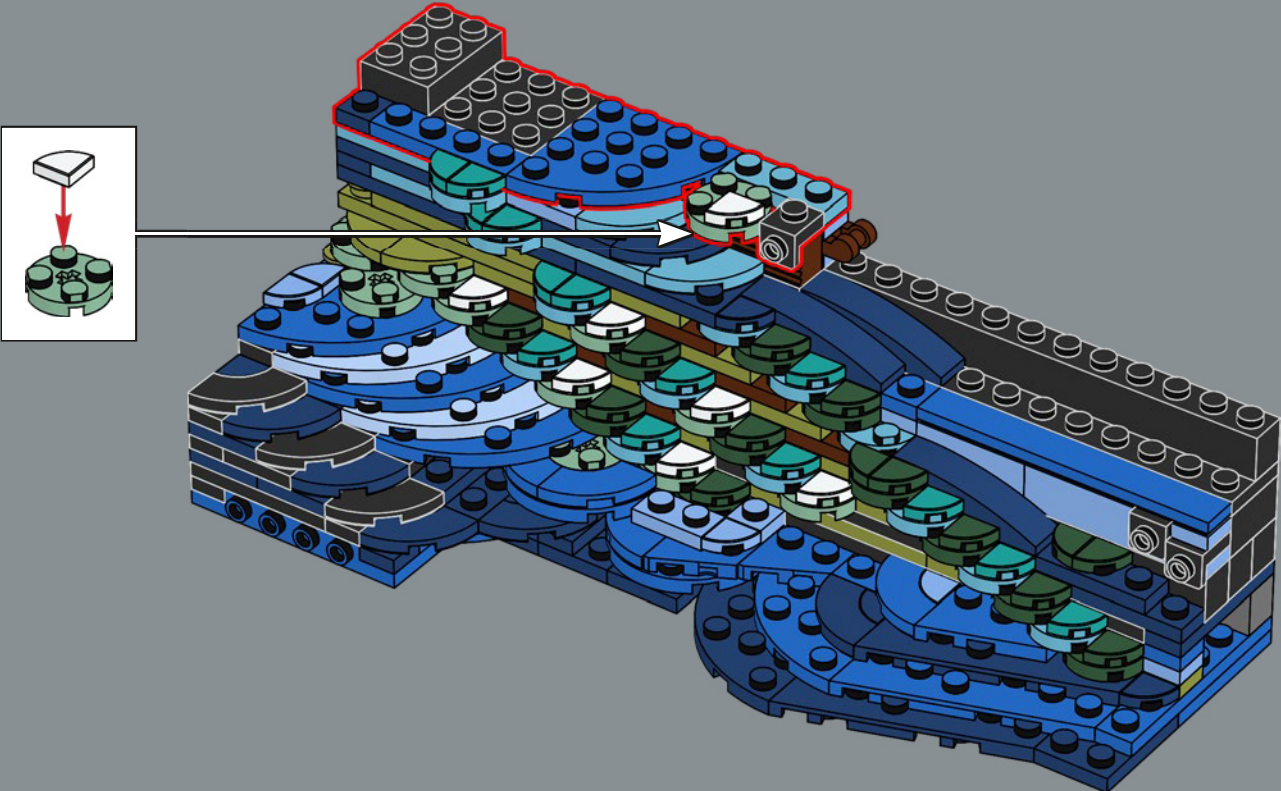

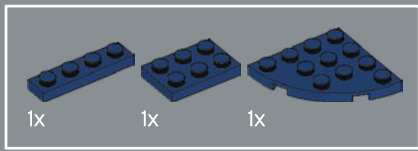

64

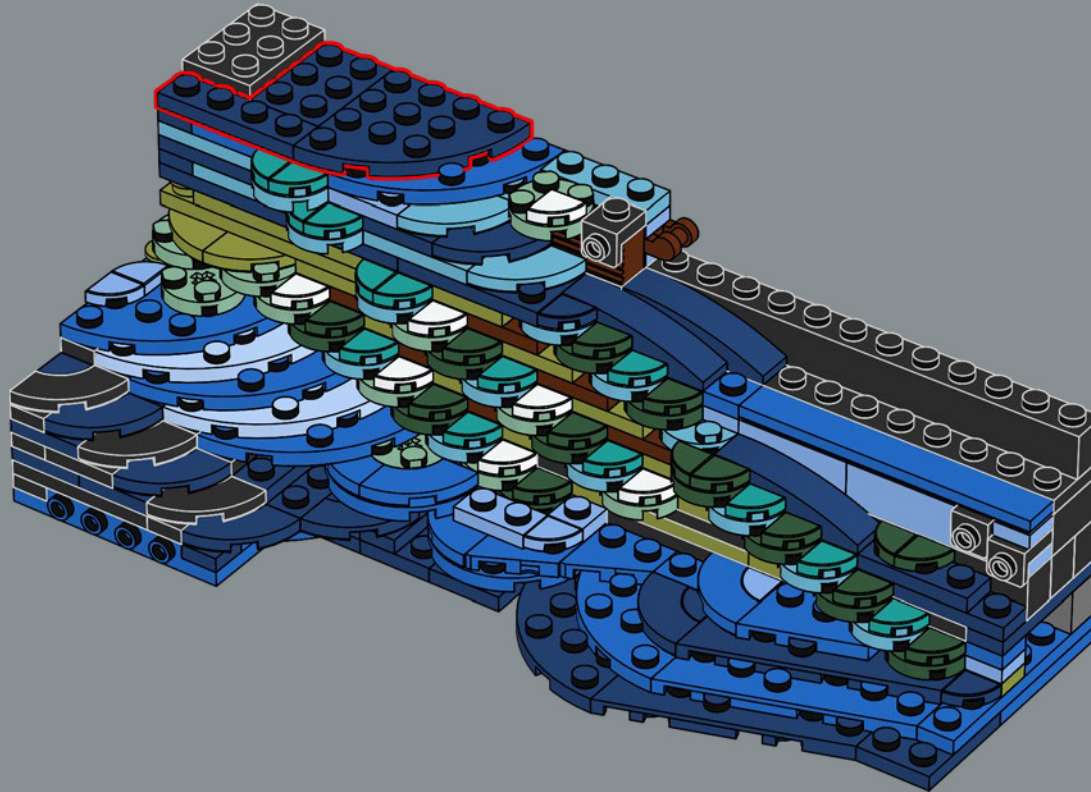

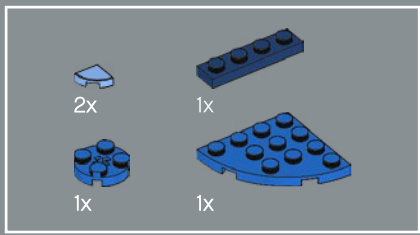

65

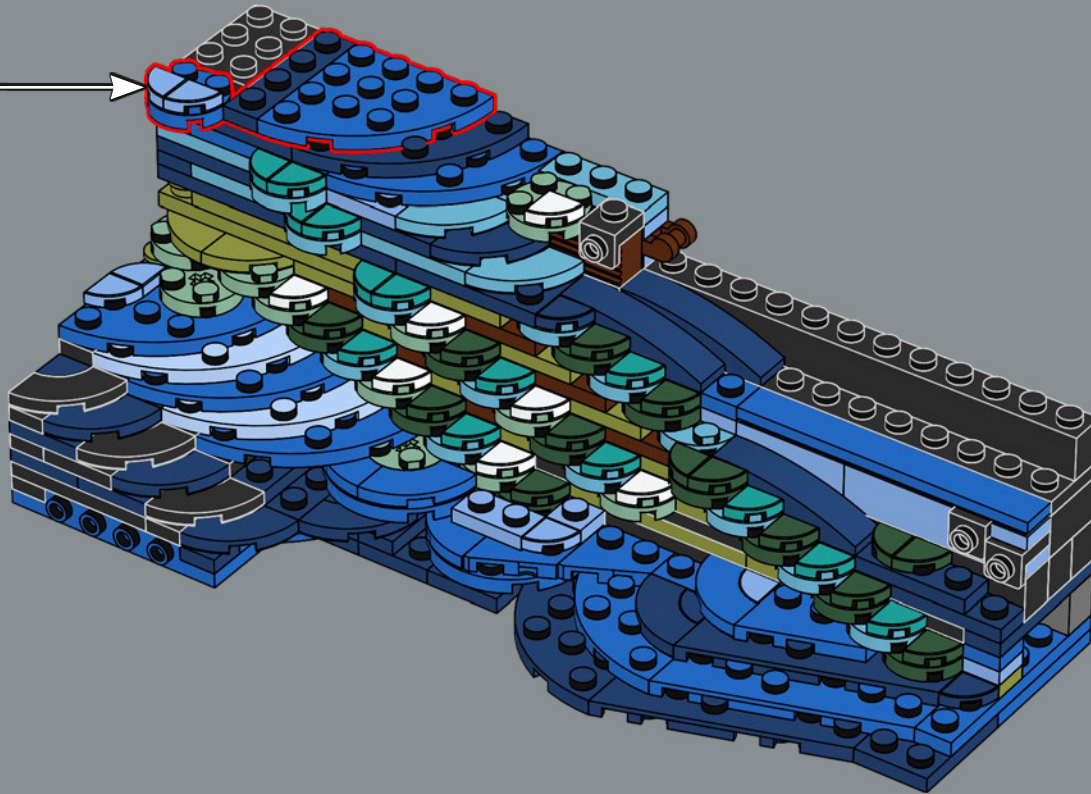
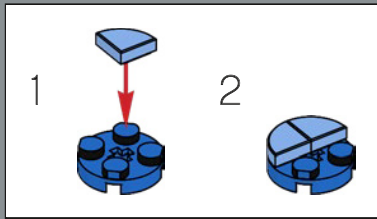

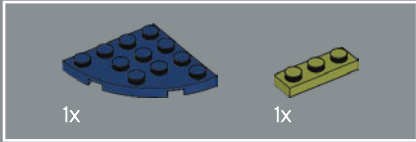

66

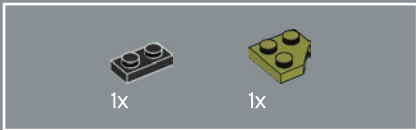
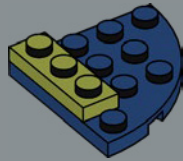

67

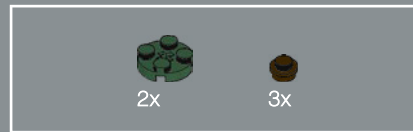
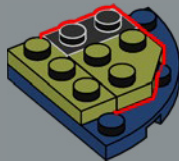

68

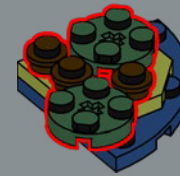

69

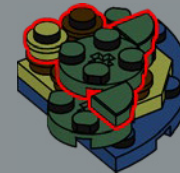

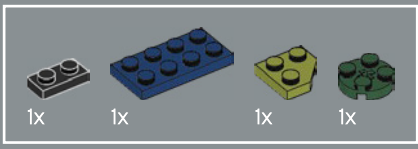

70

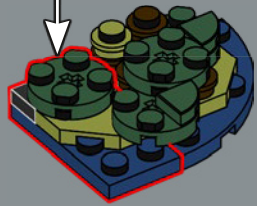
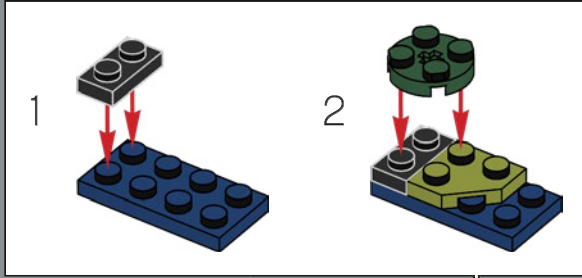

71

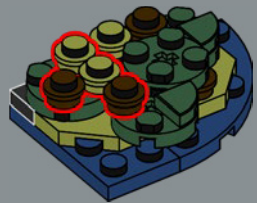

78



72

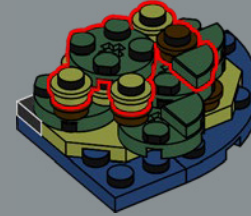

73

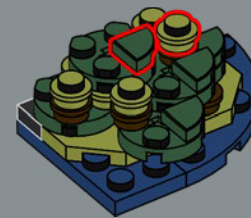

74

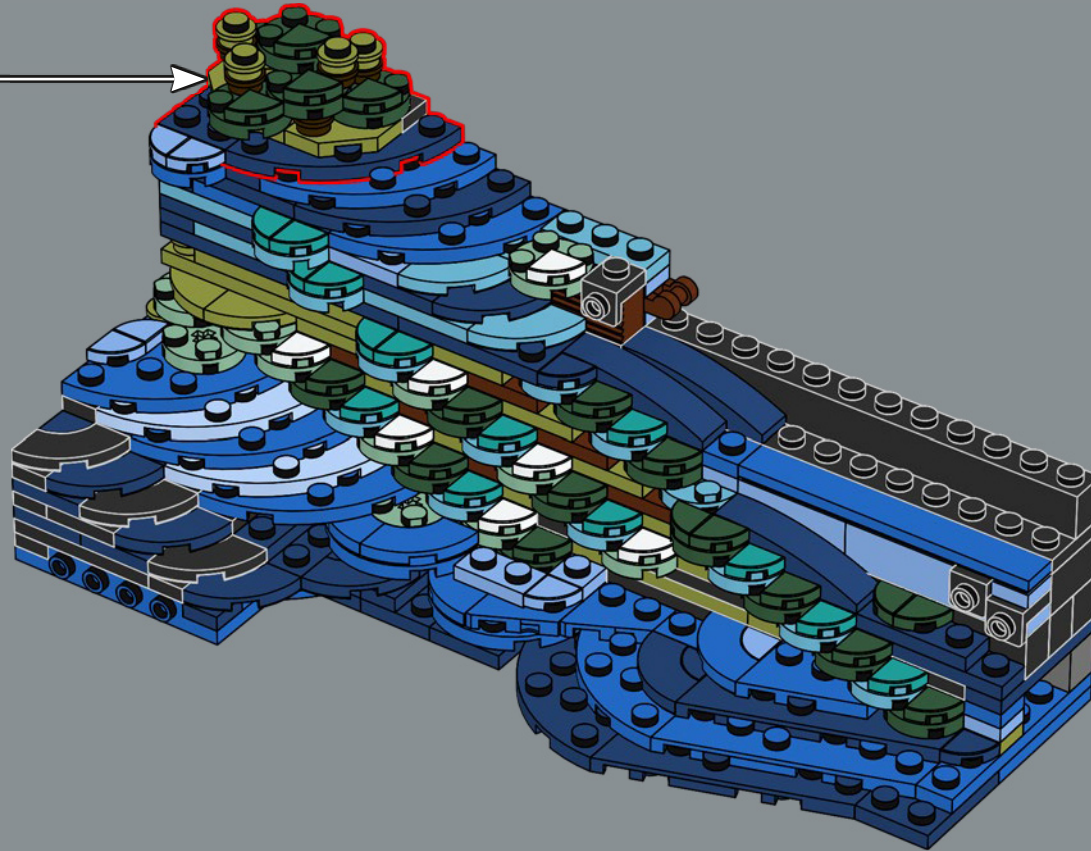

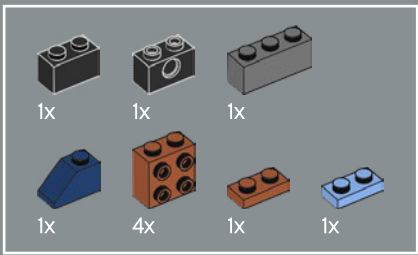

75

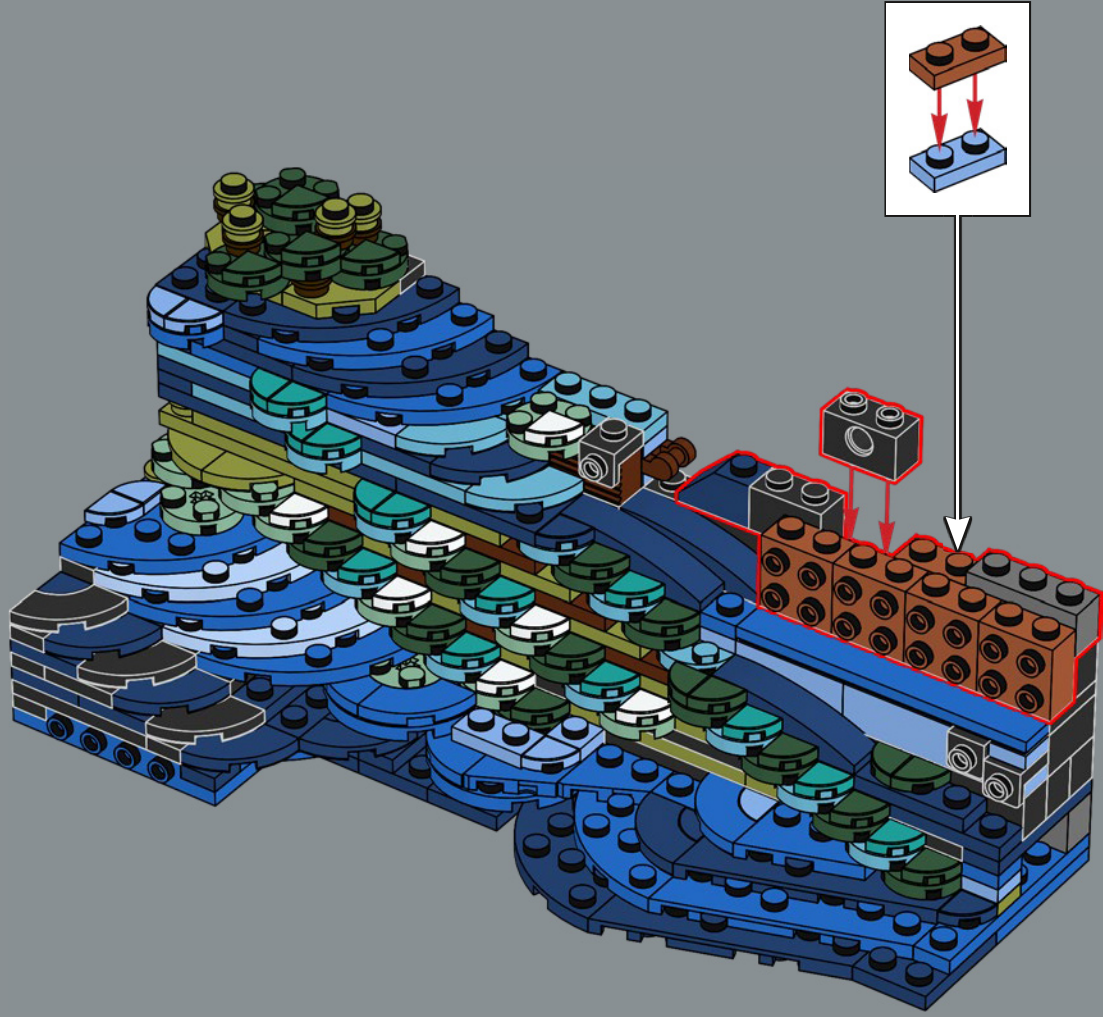

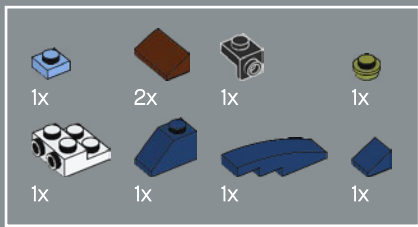

76

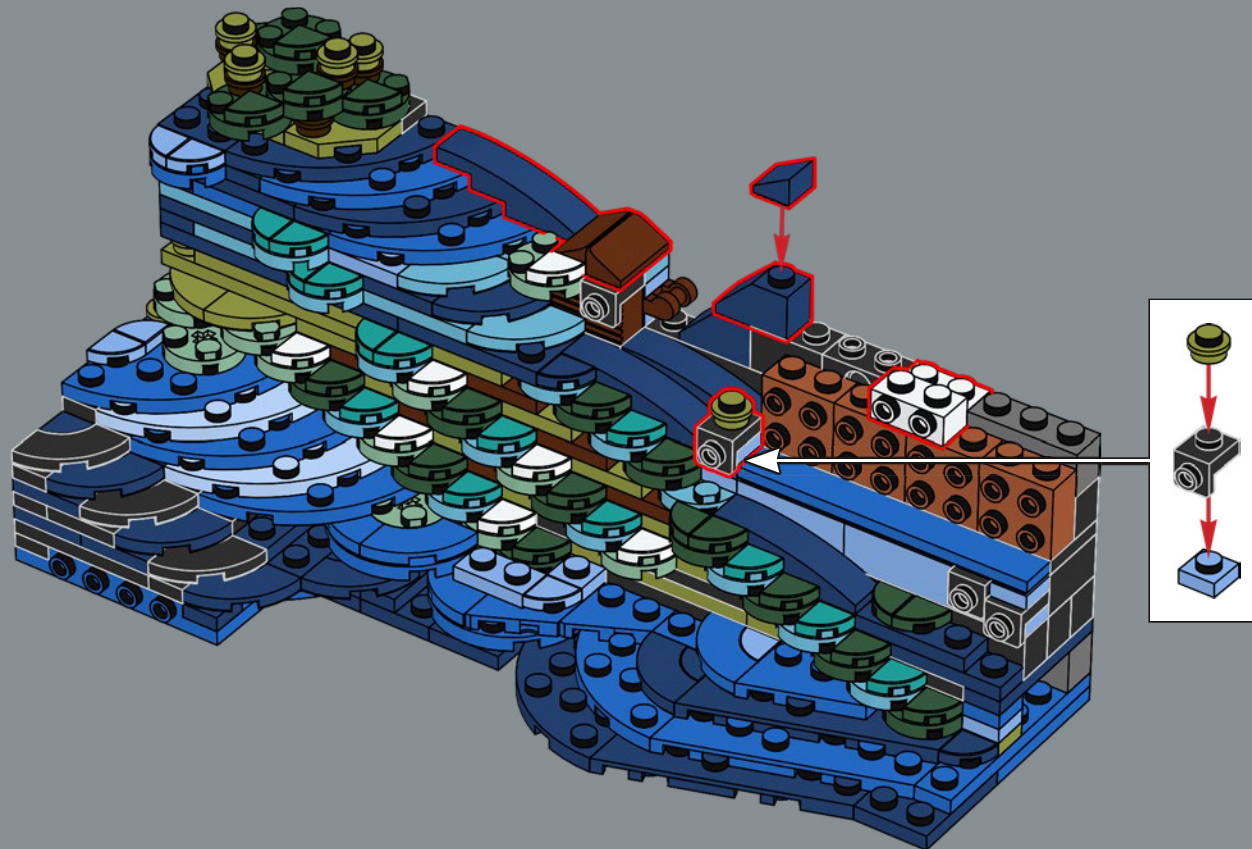

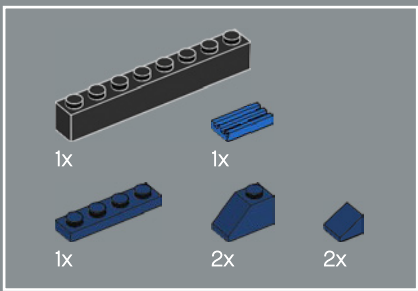

77

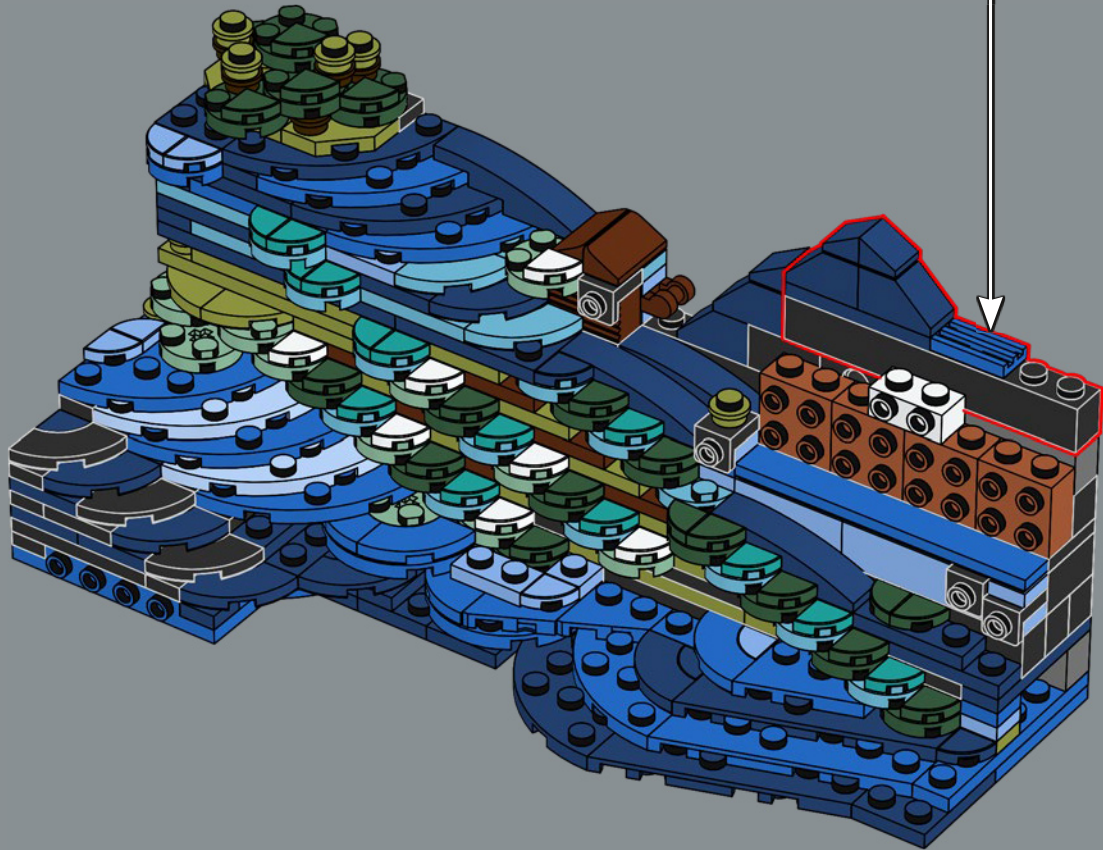
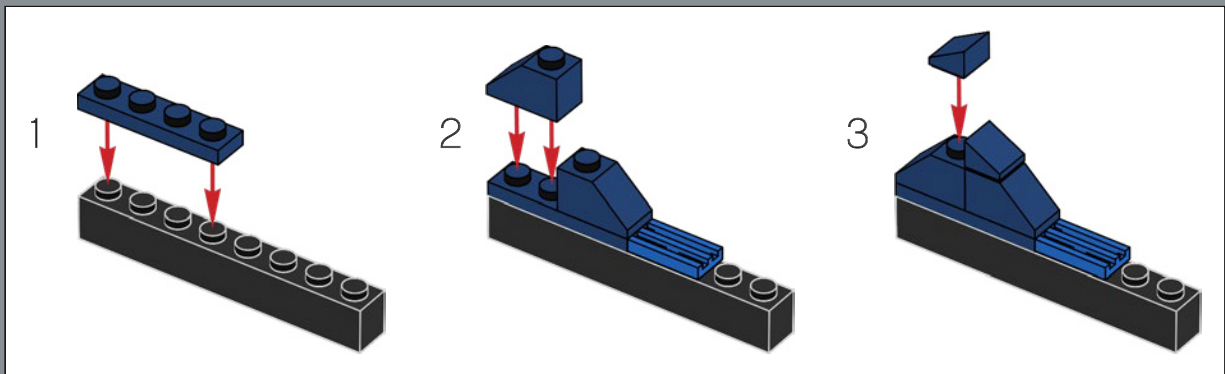

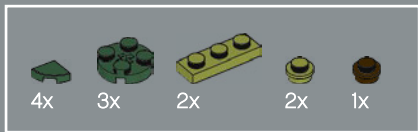

78

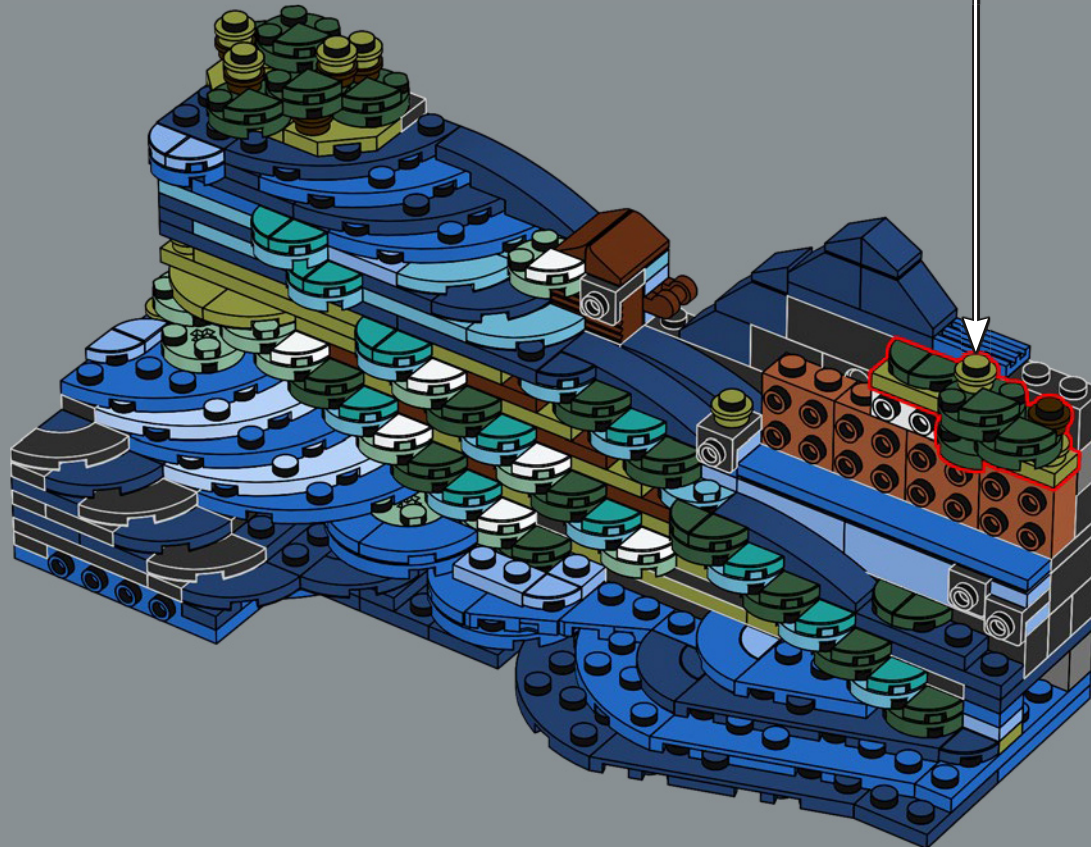
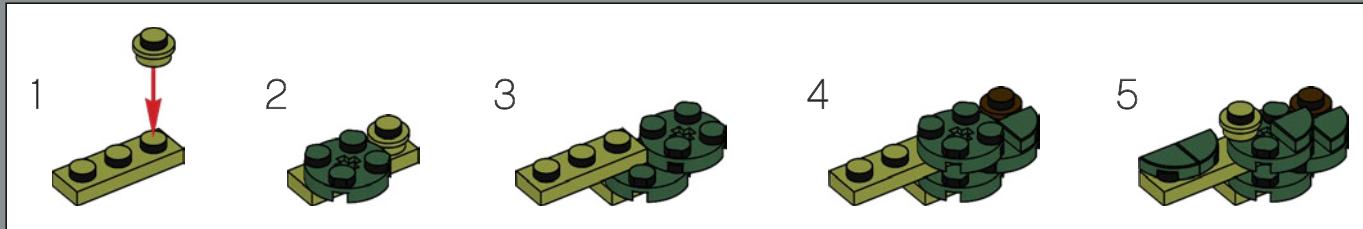

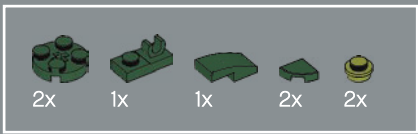

79

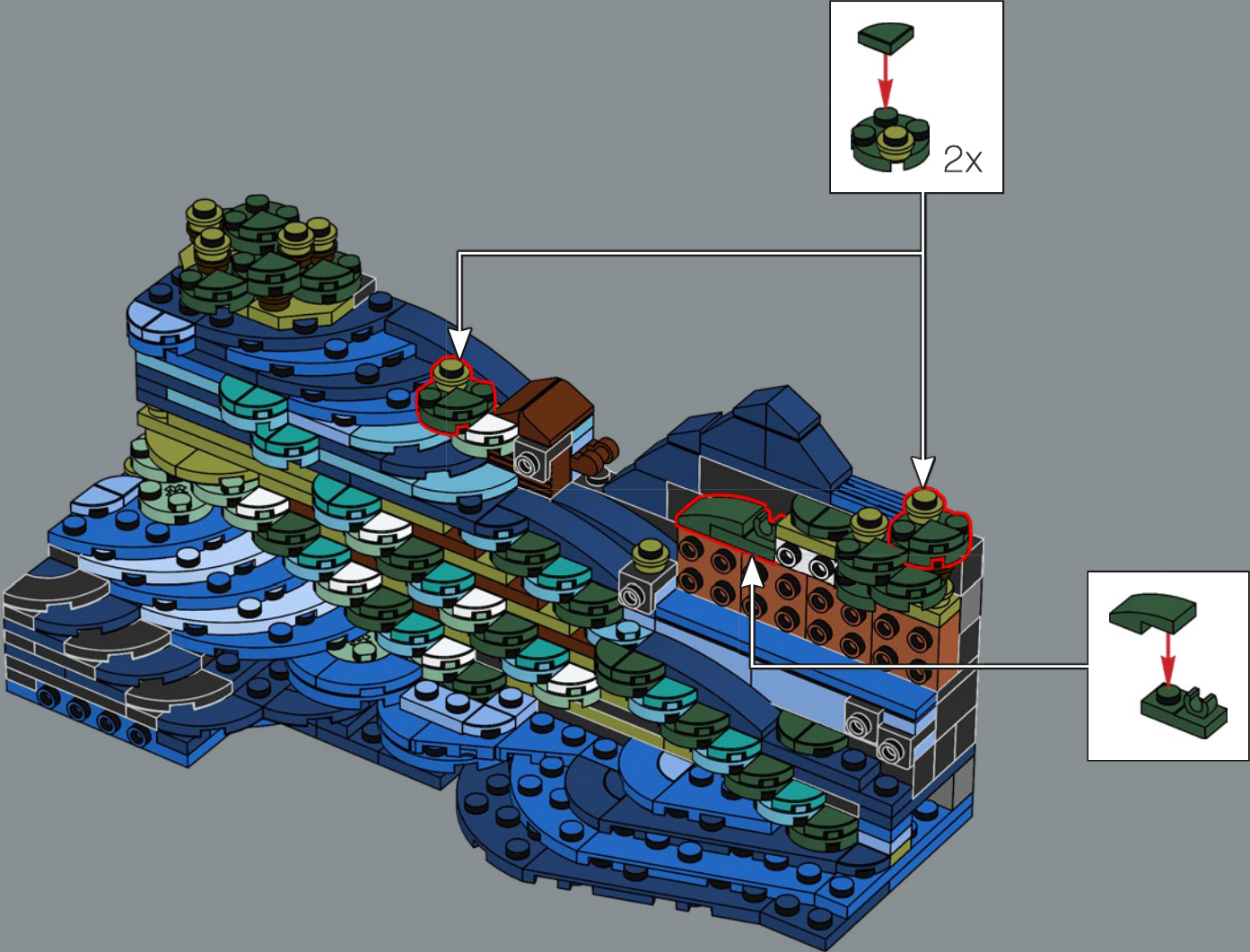

- 
4x
- 
4x
- 
2x
- 
2x

80

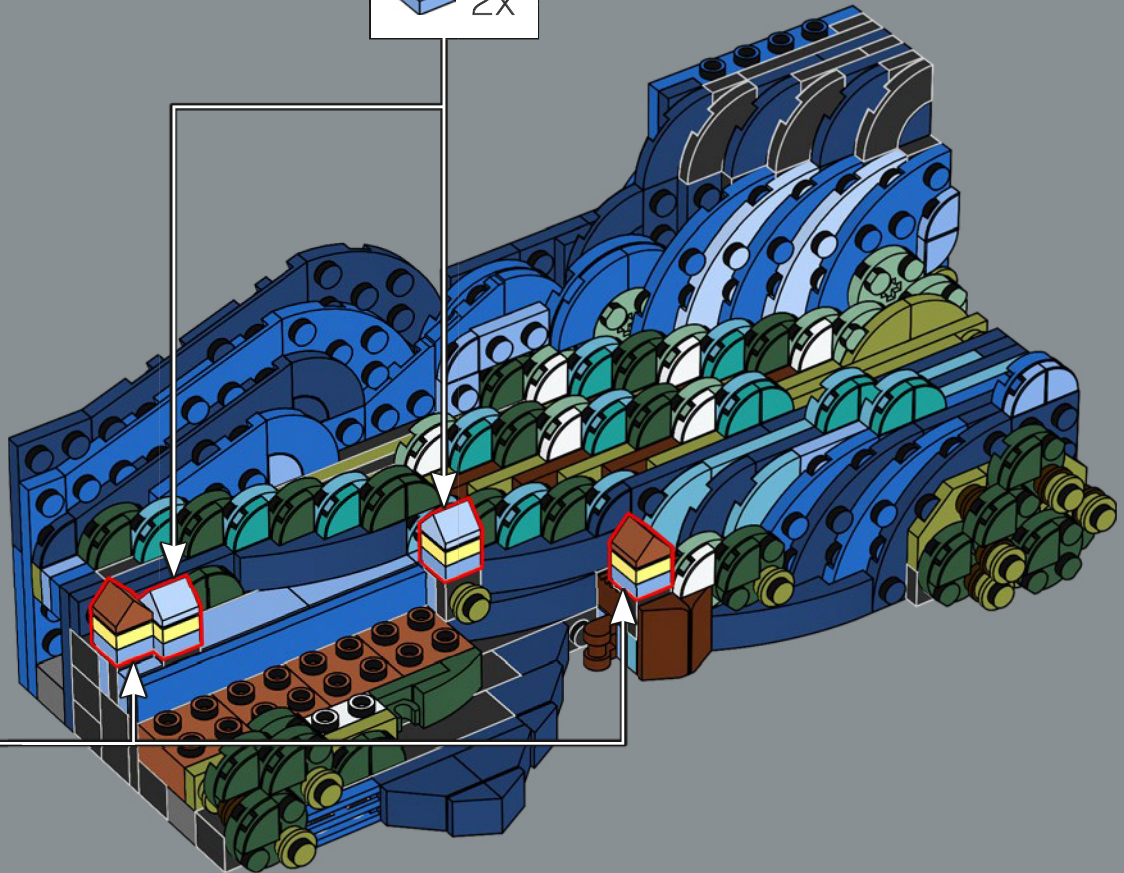
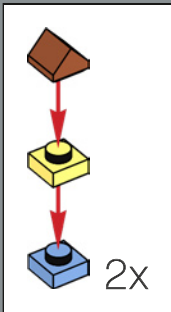
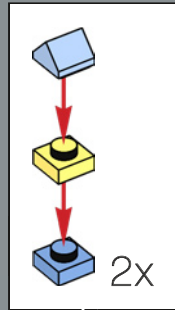

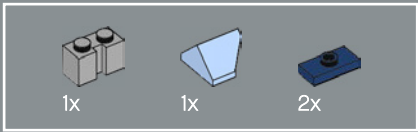

81

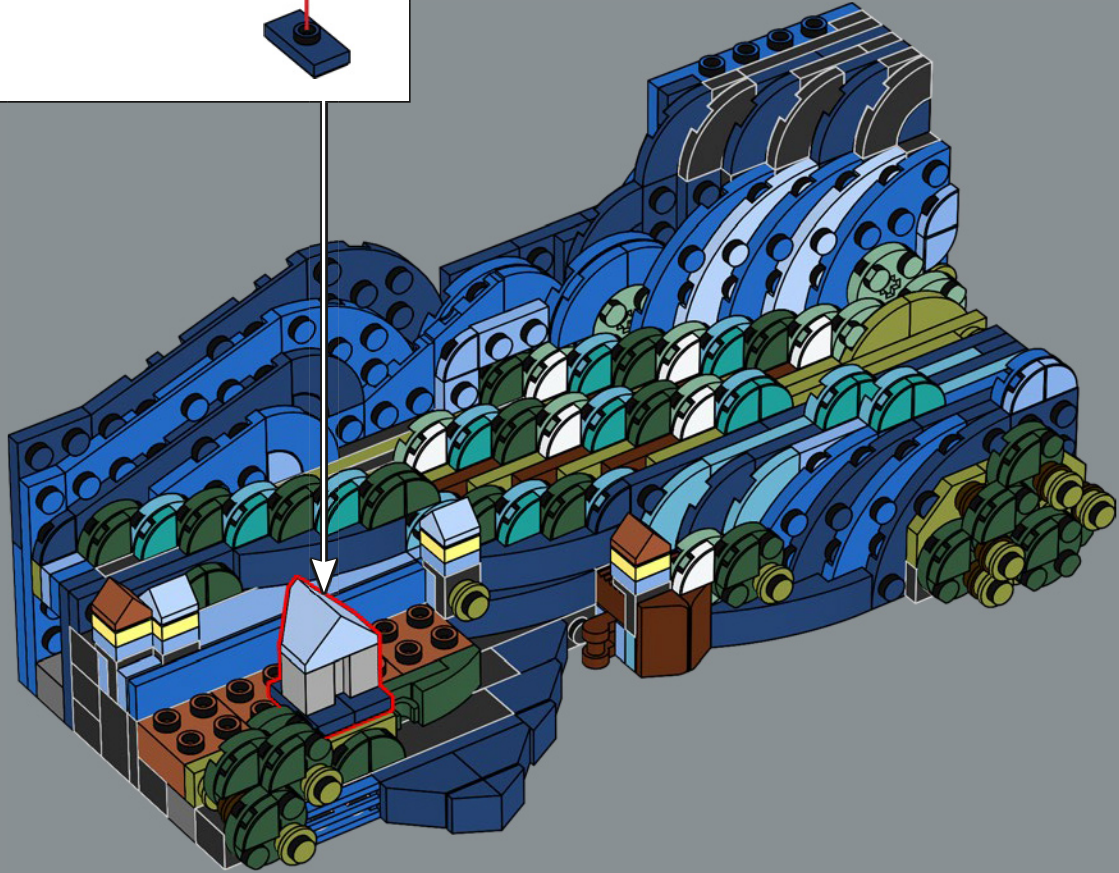
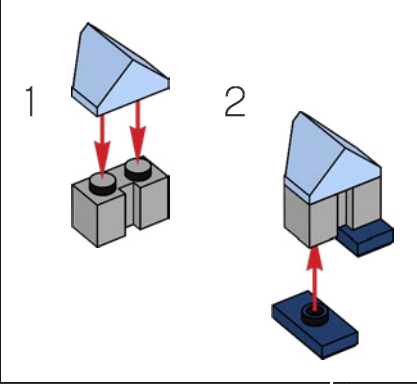

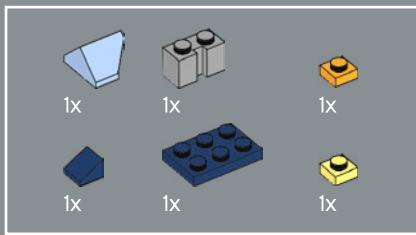

82

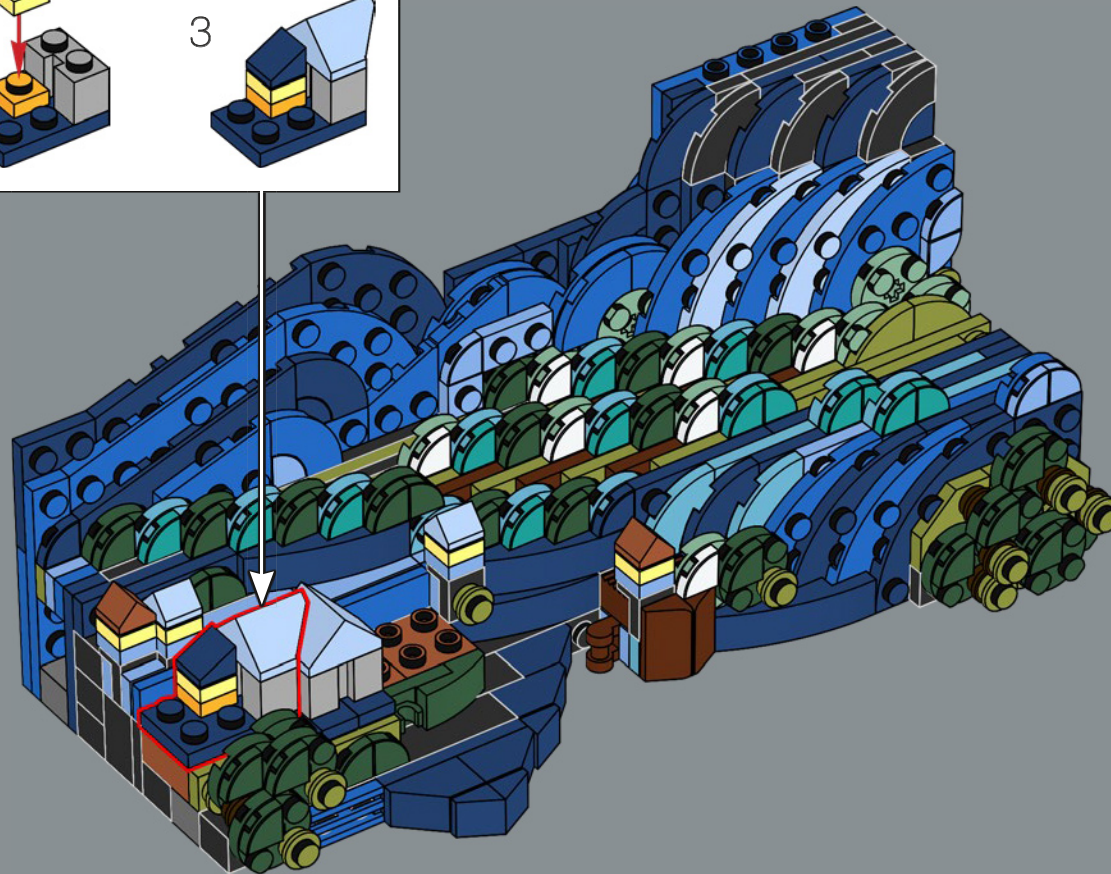
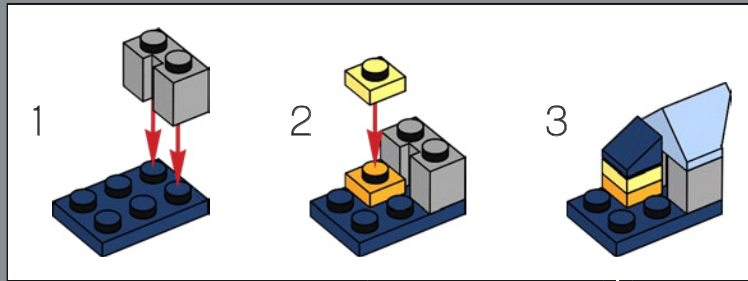

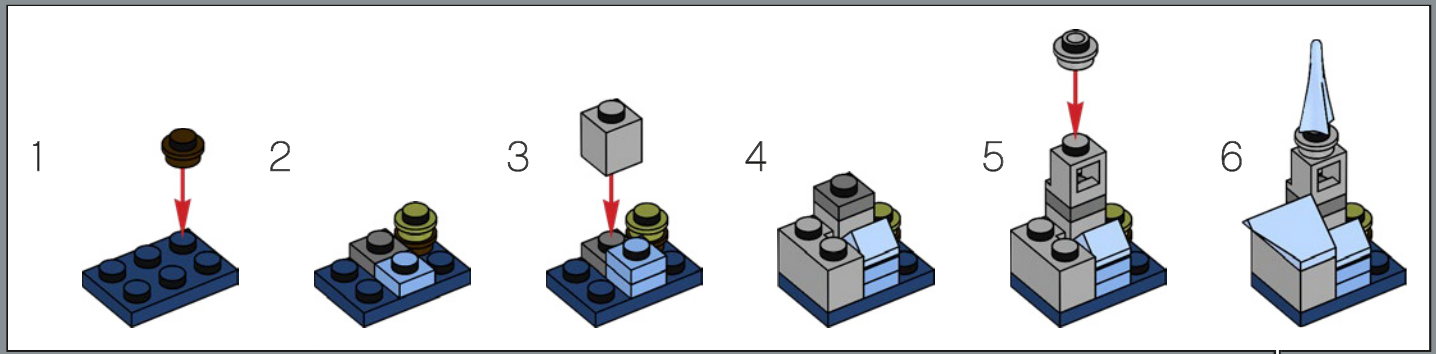
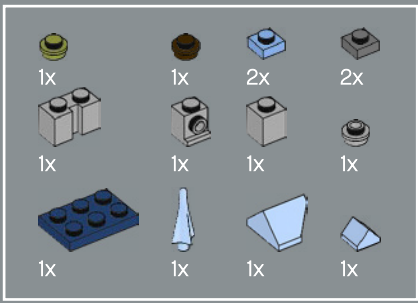

83

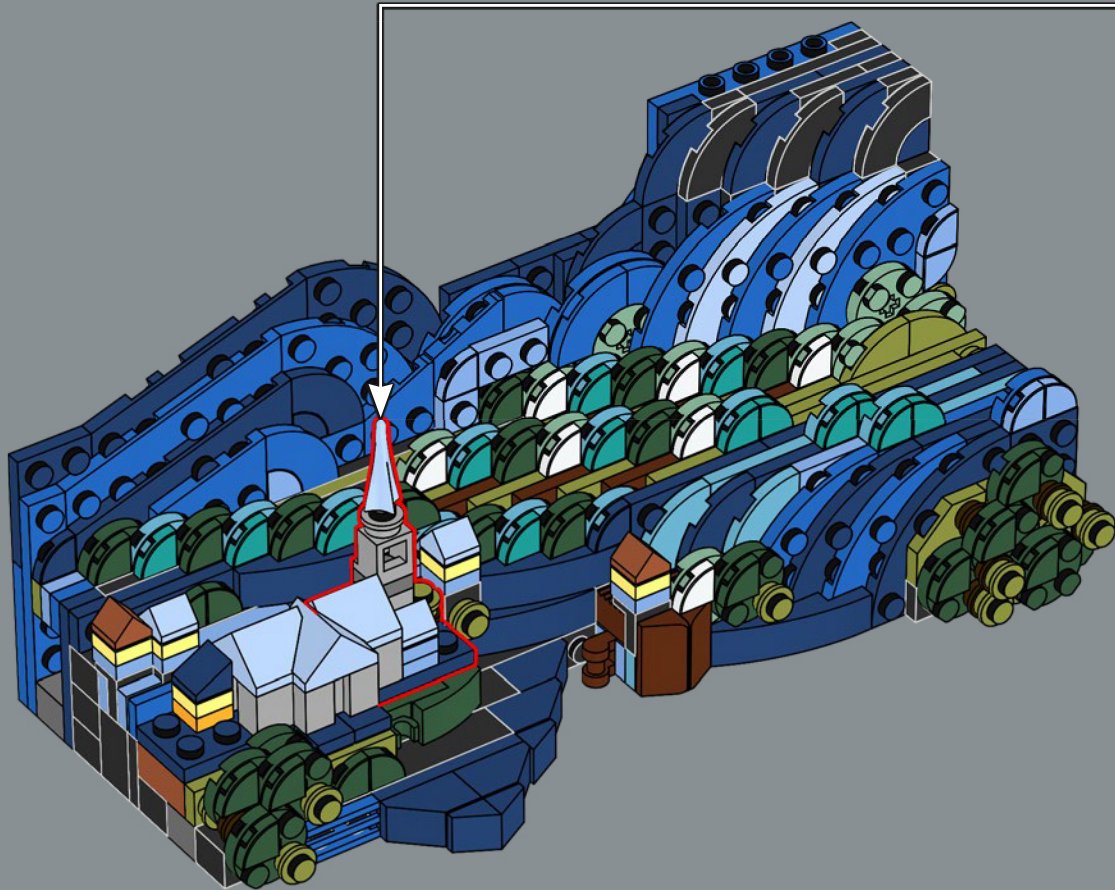

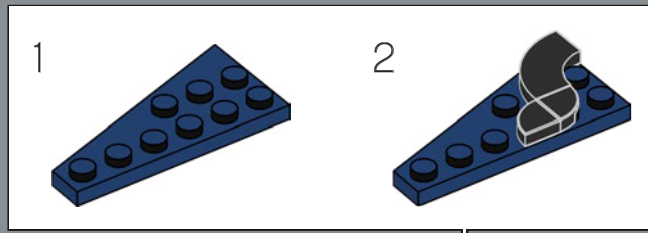
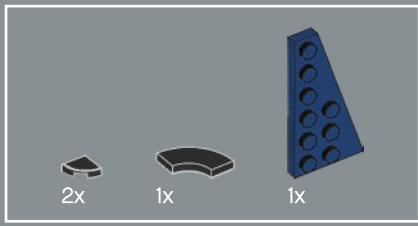

84

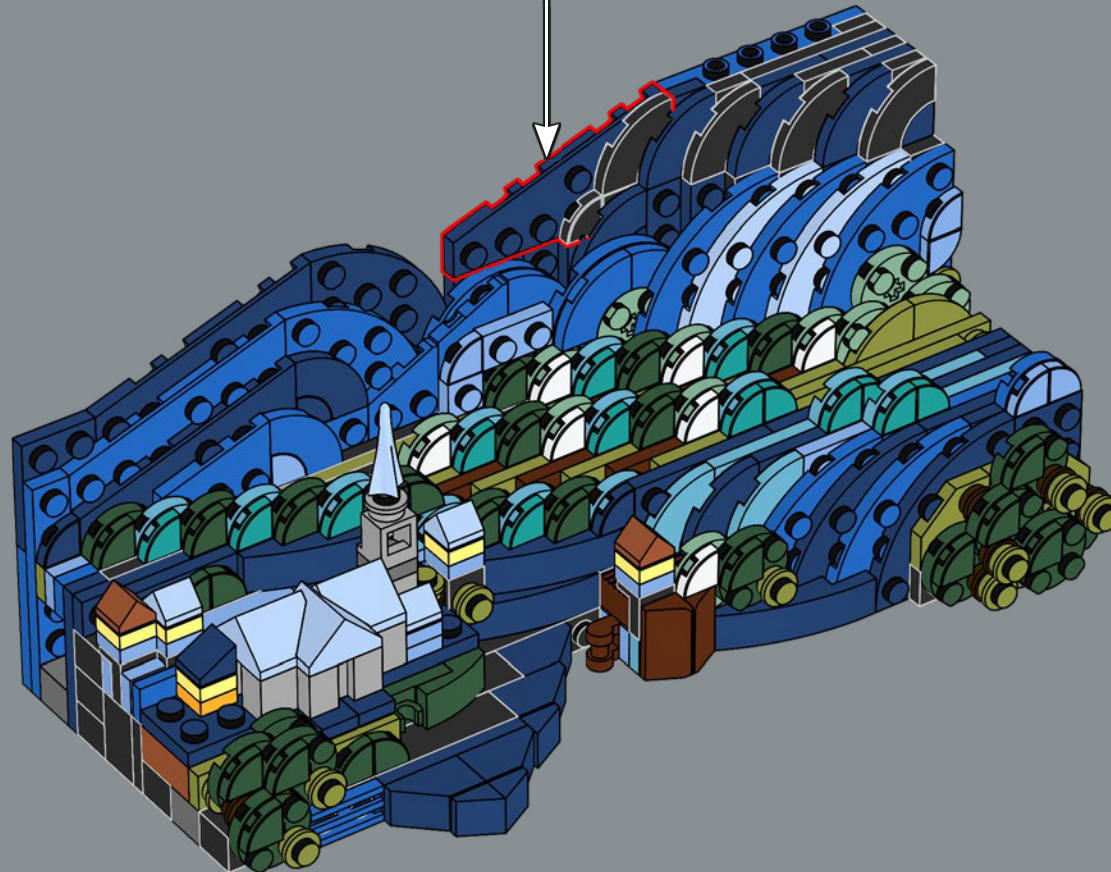

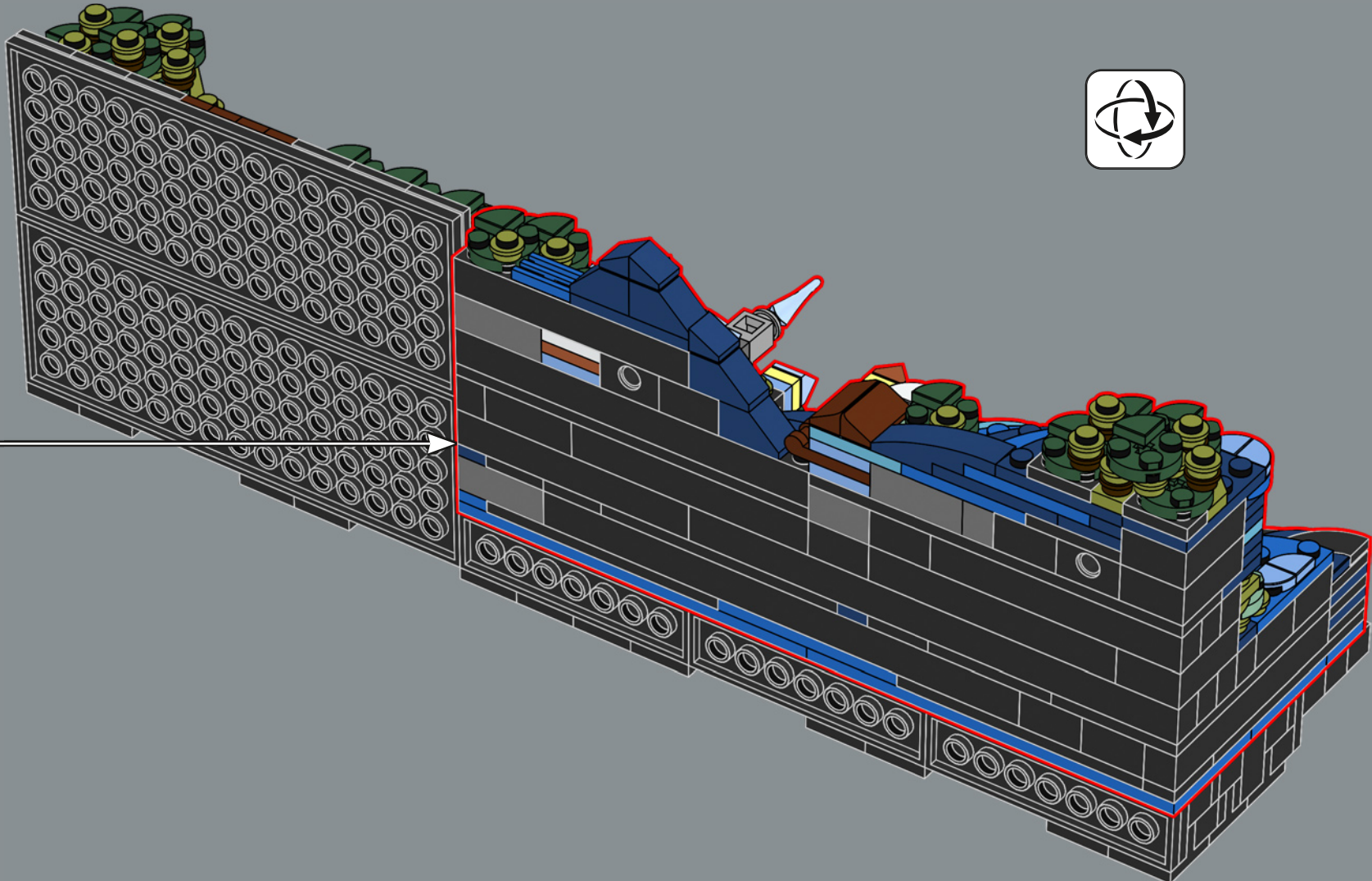

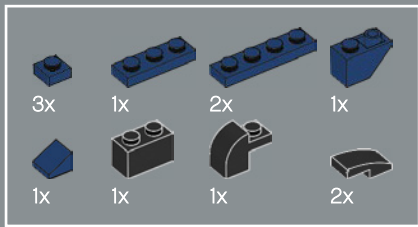

86

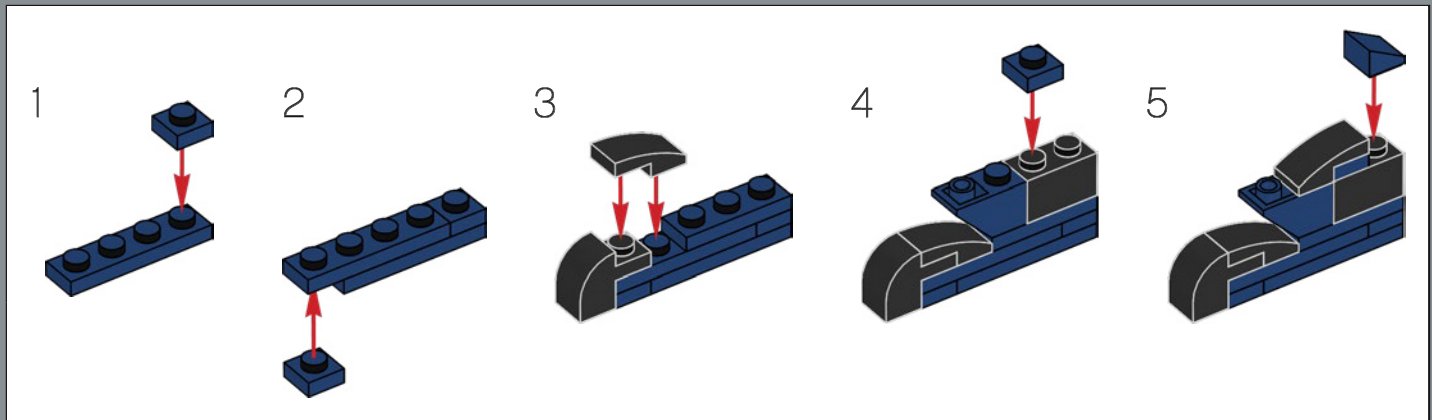



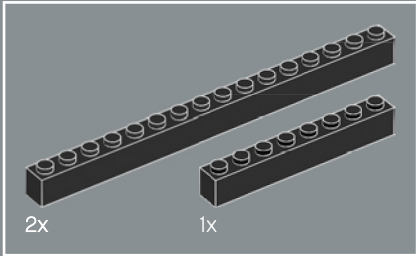
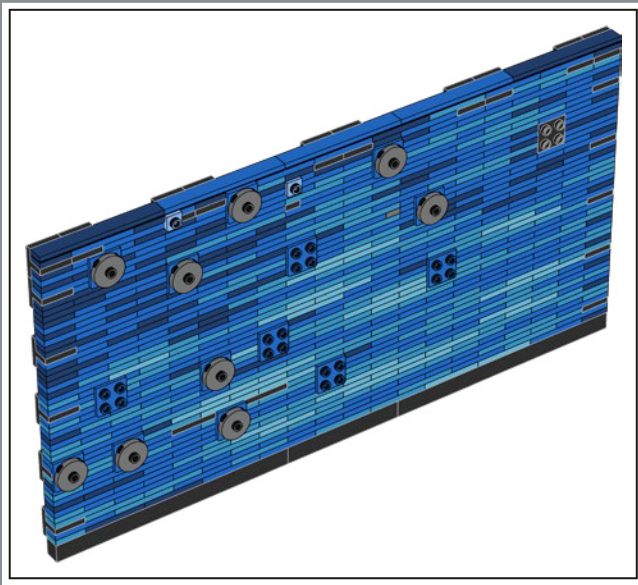

87

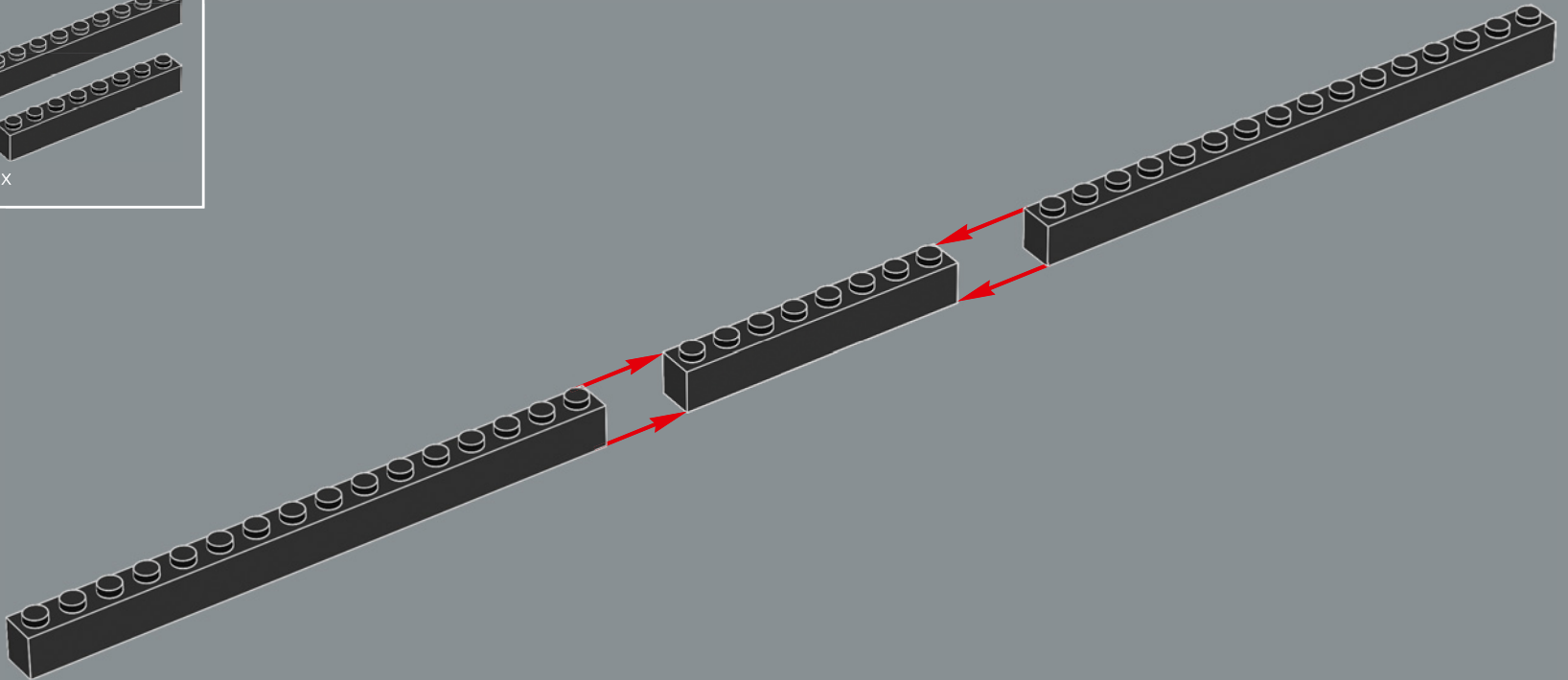

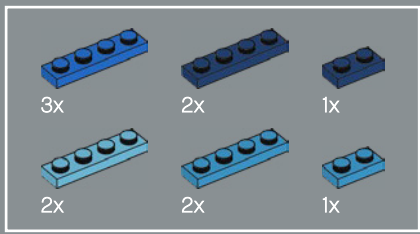

88

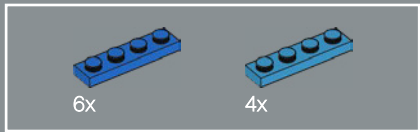
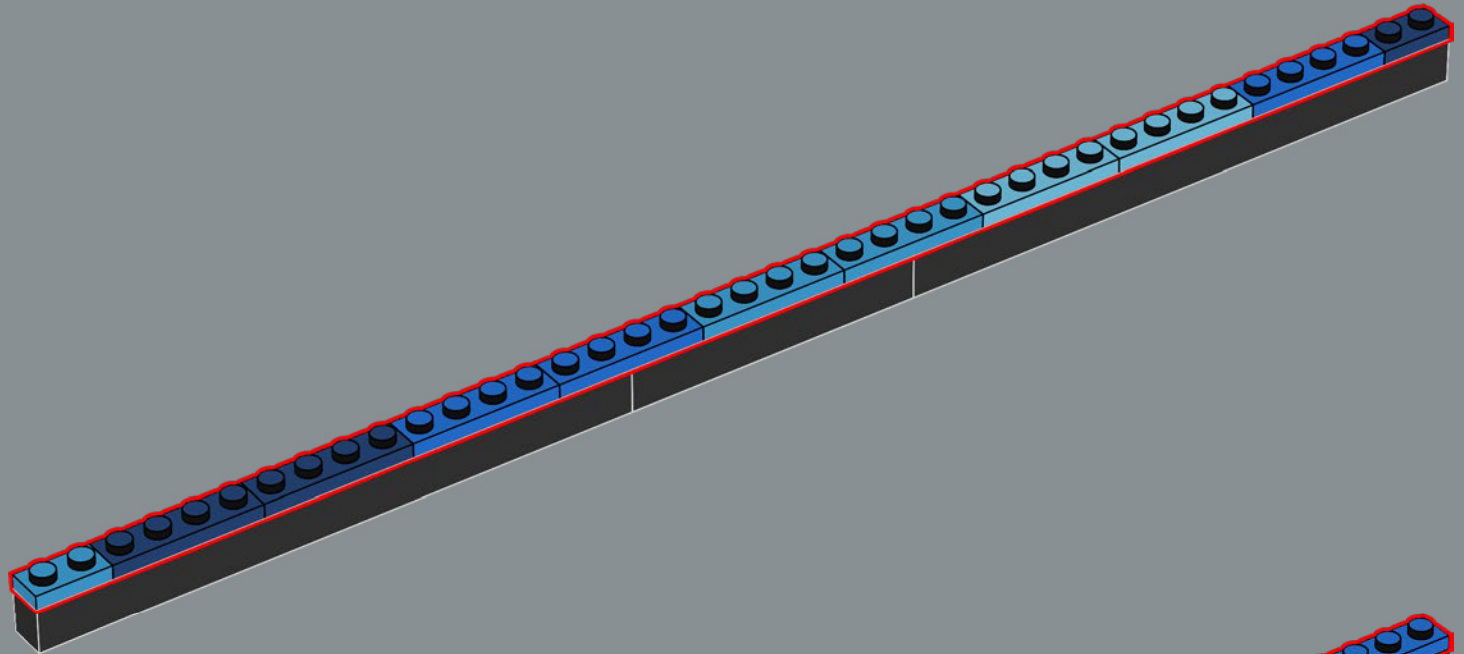

89

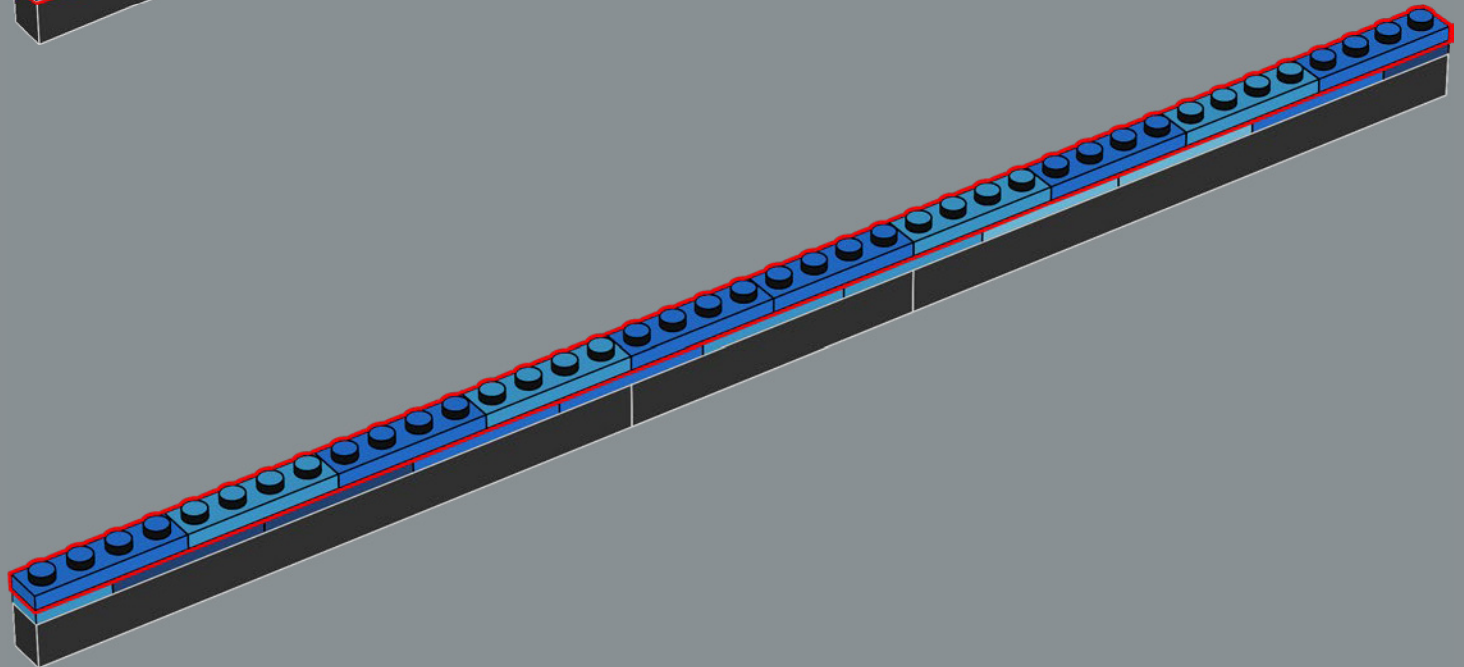

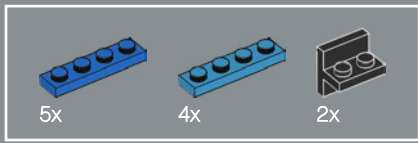

90

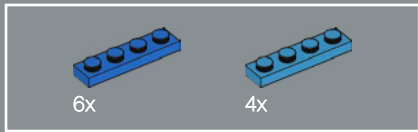
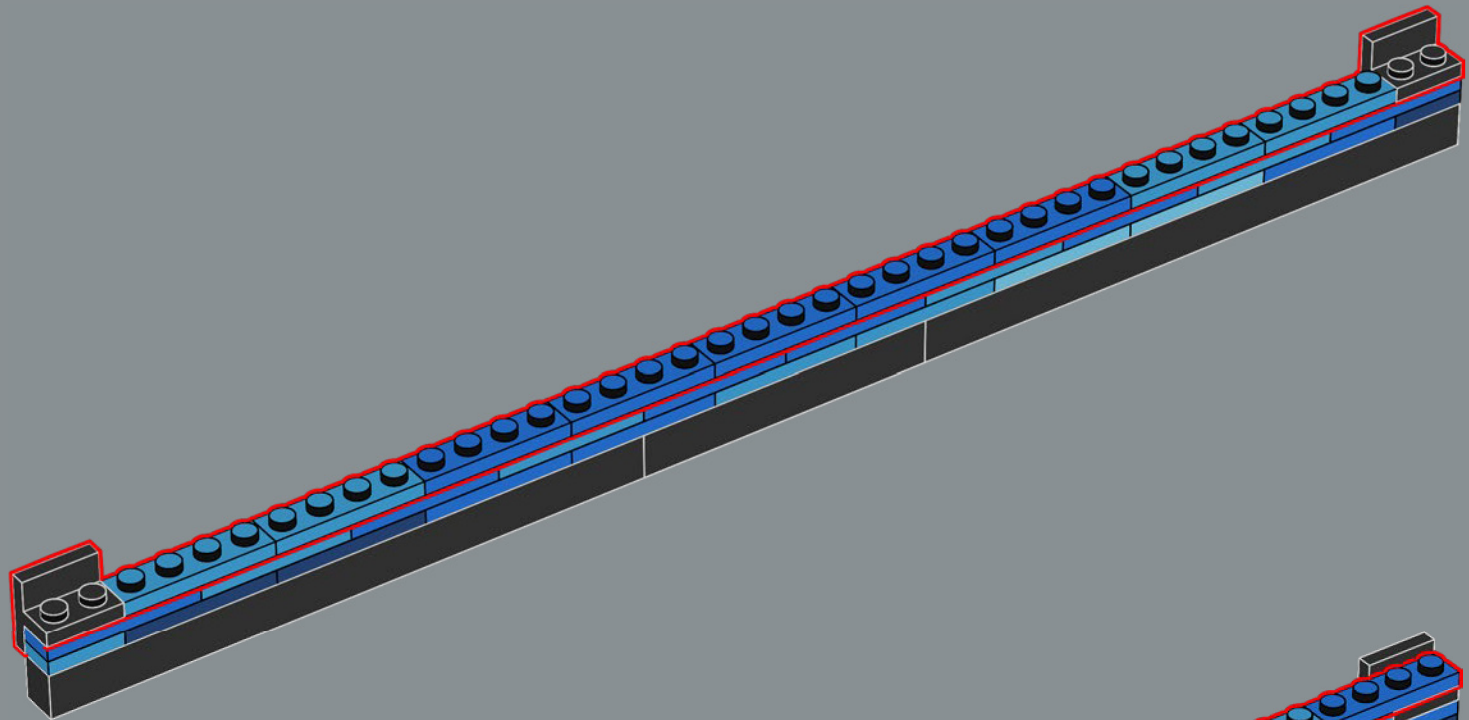

91

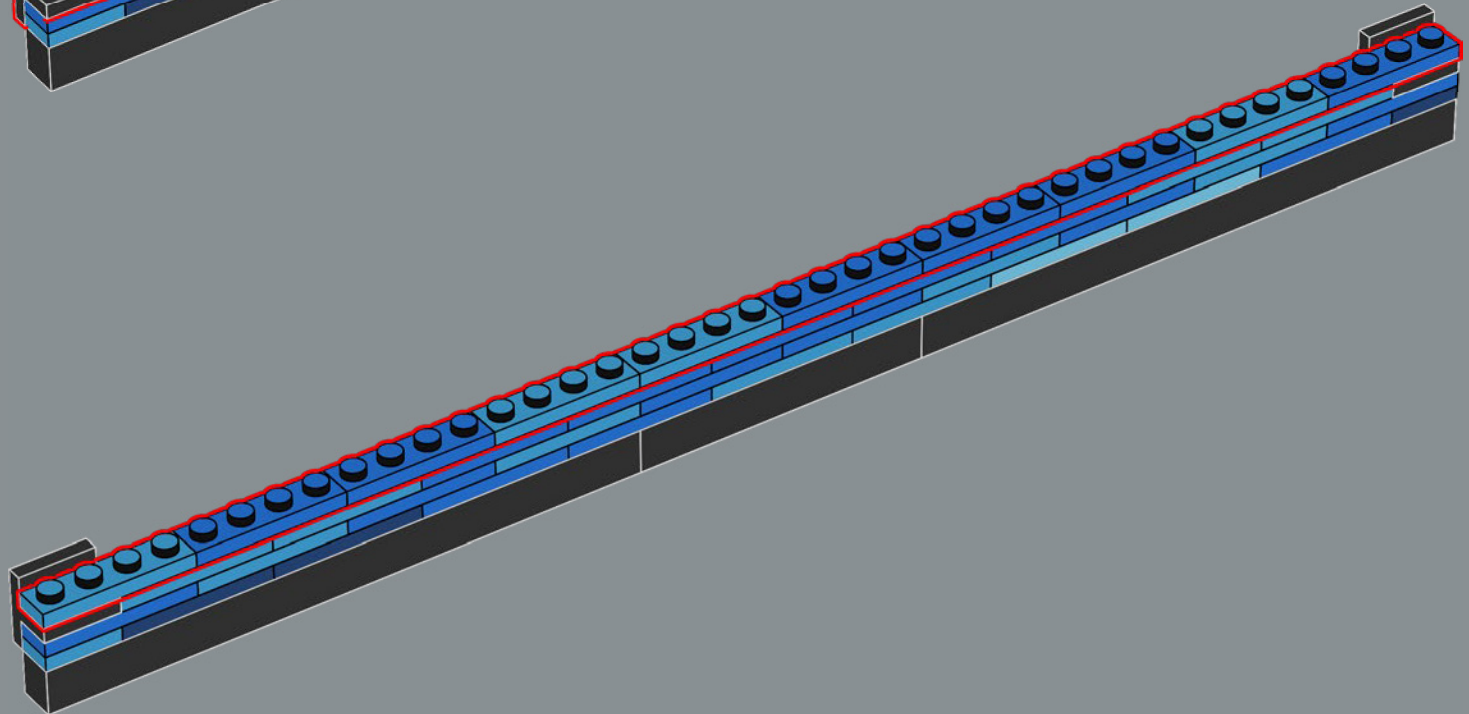

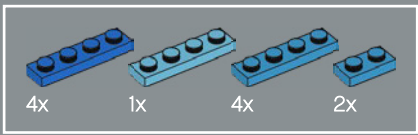

92

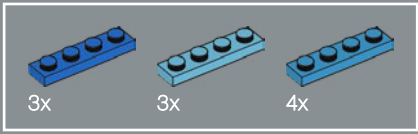
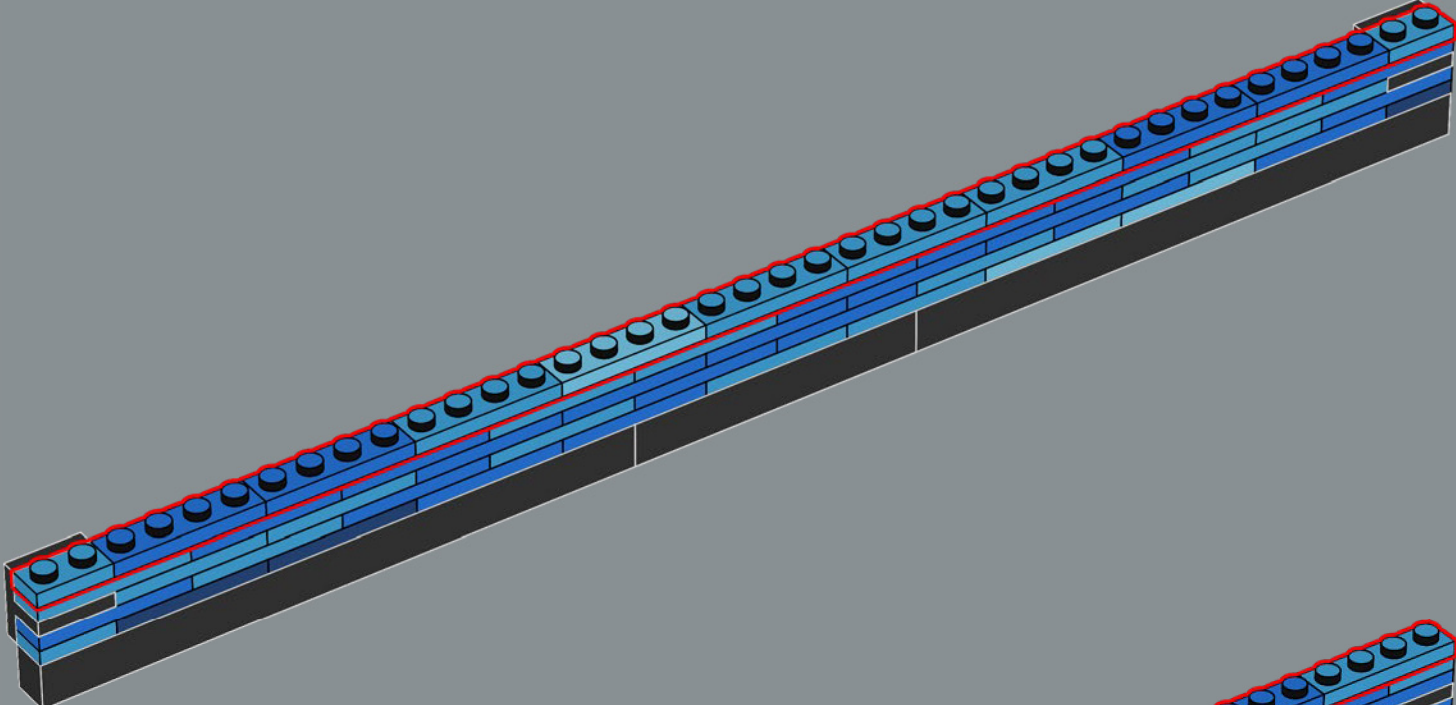

93

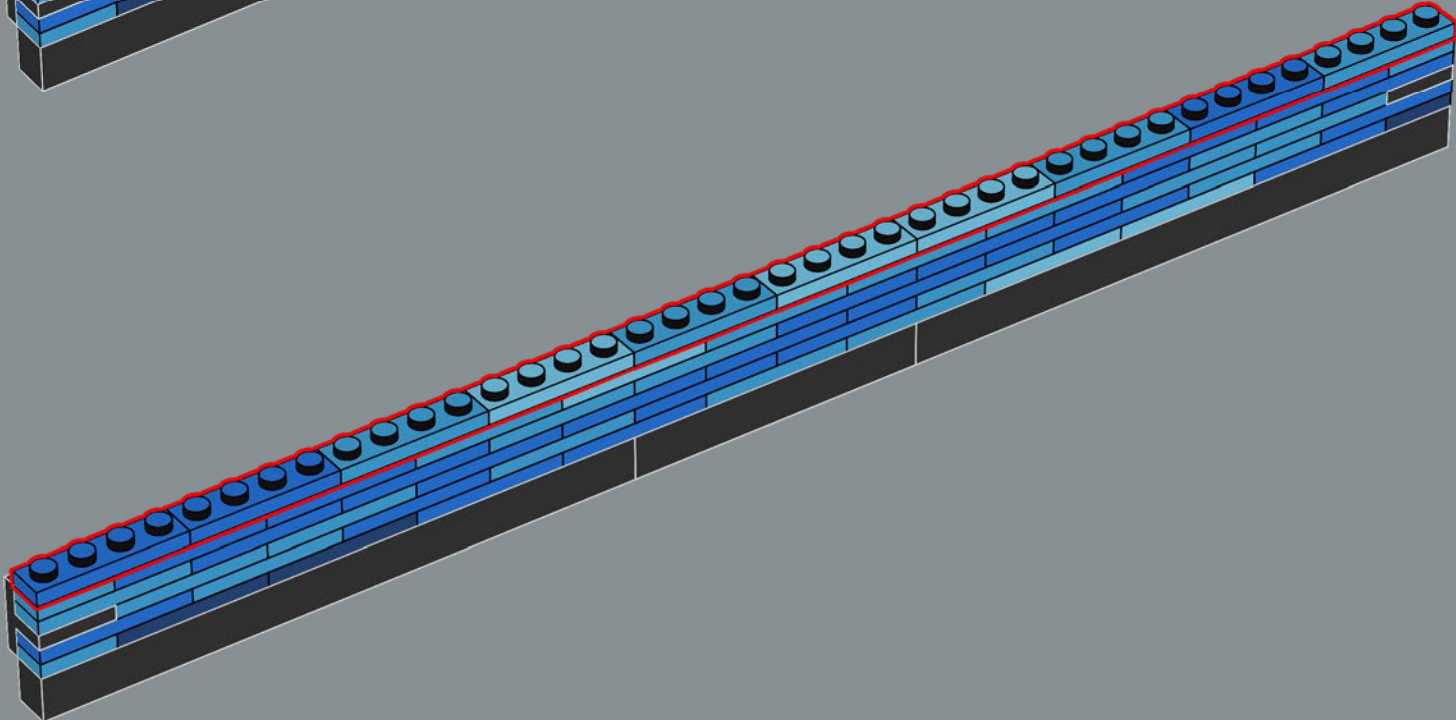

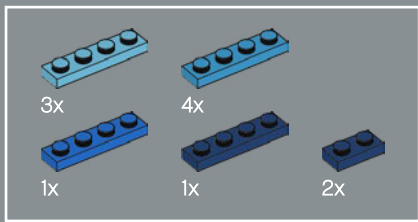

94

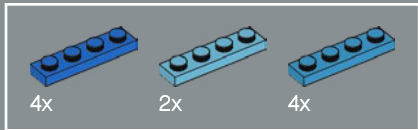
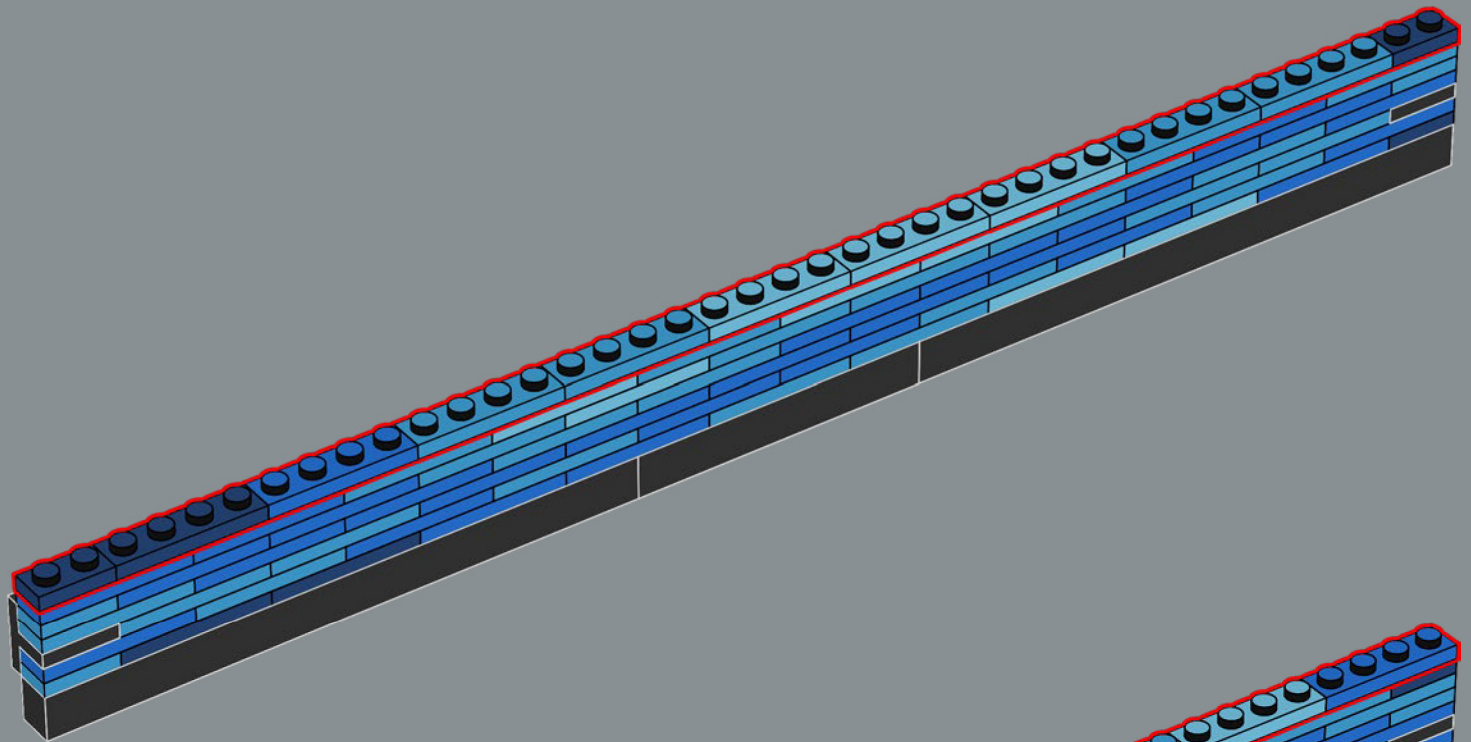

95

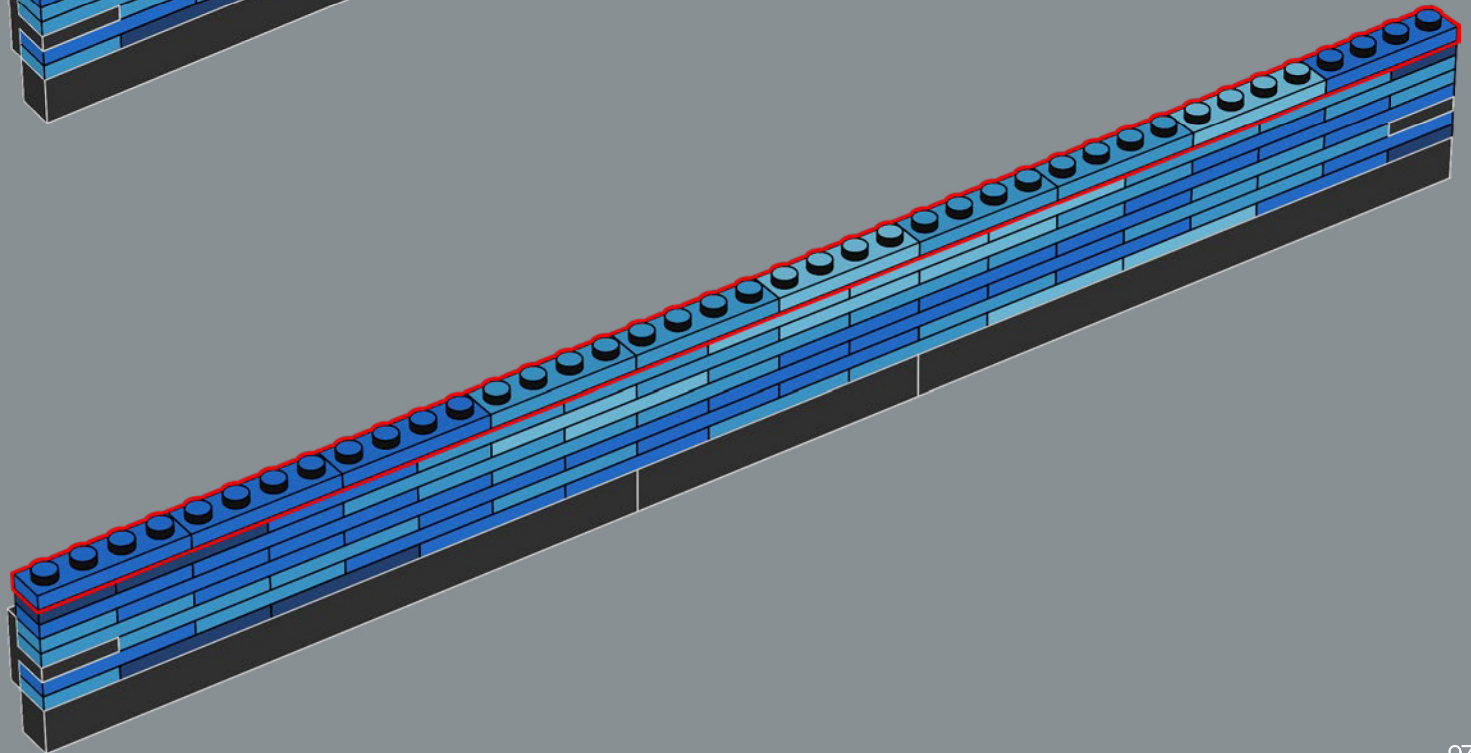

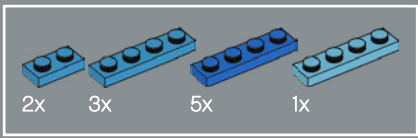

96

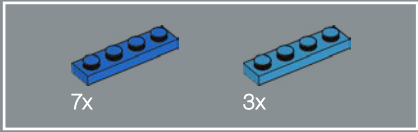
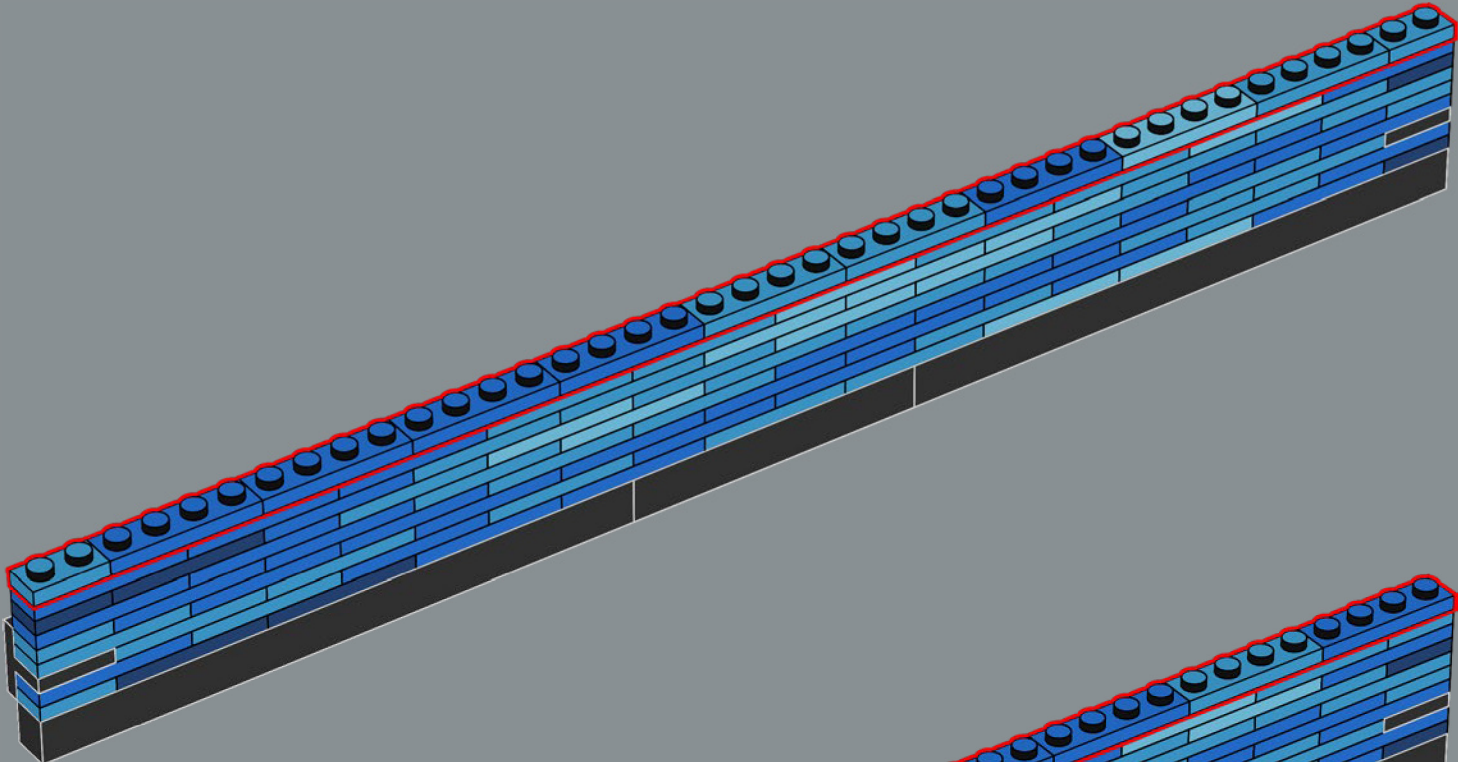

97

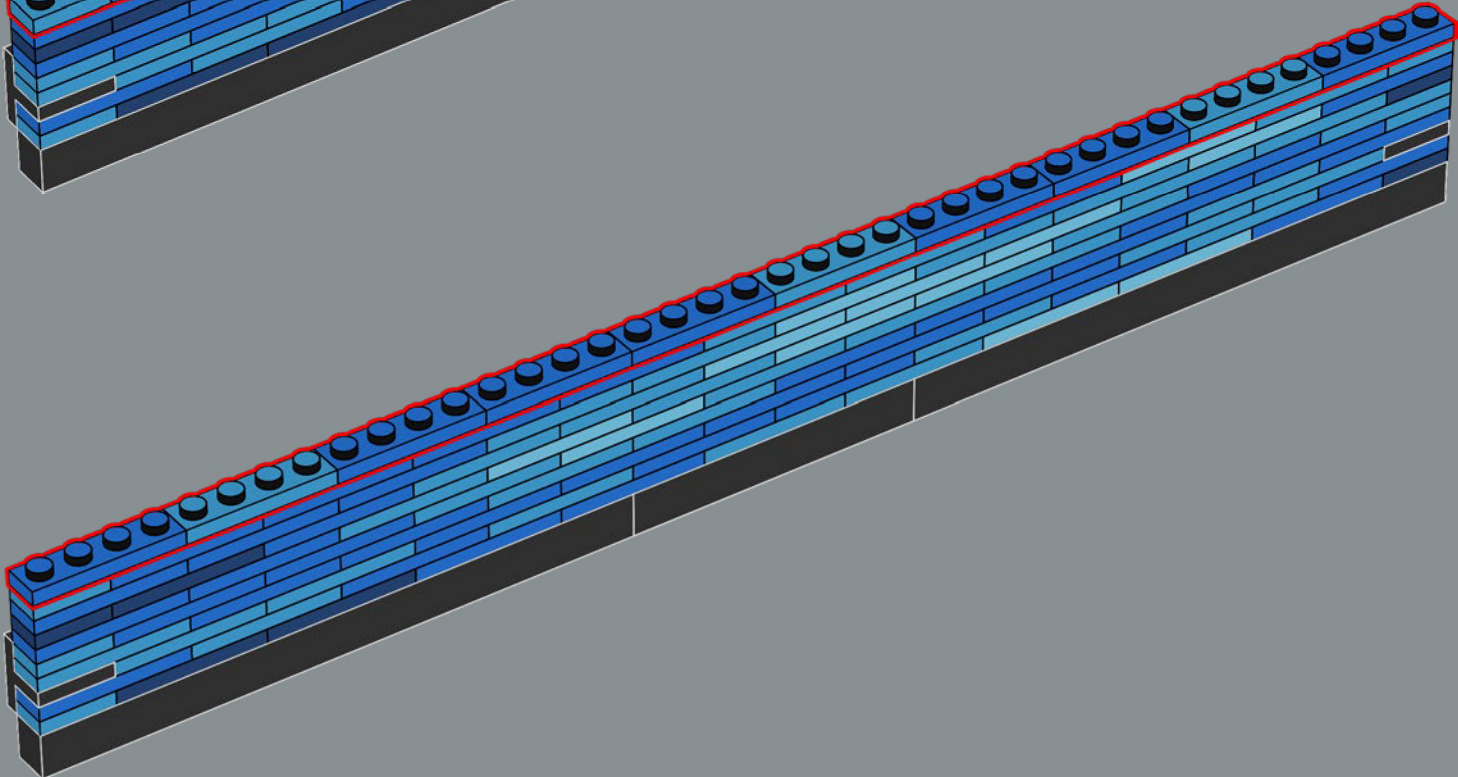

98

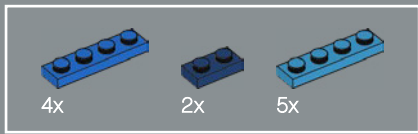

98

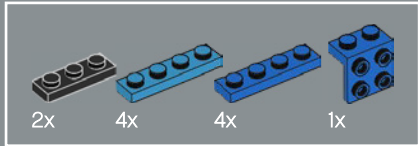
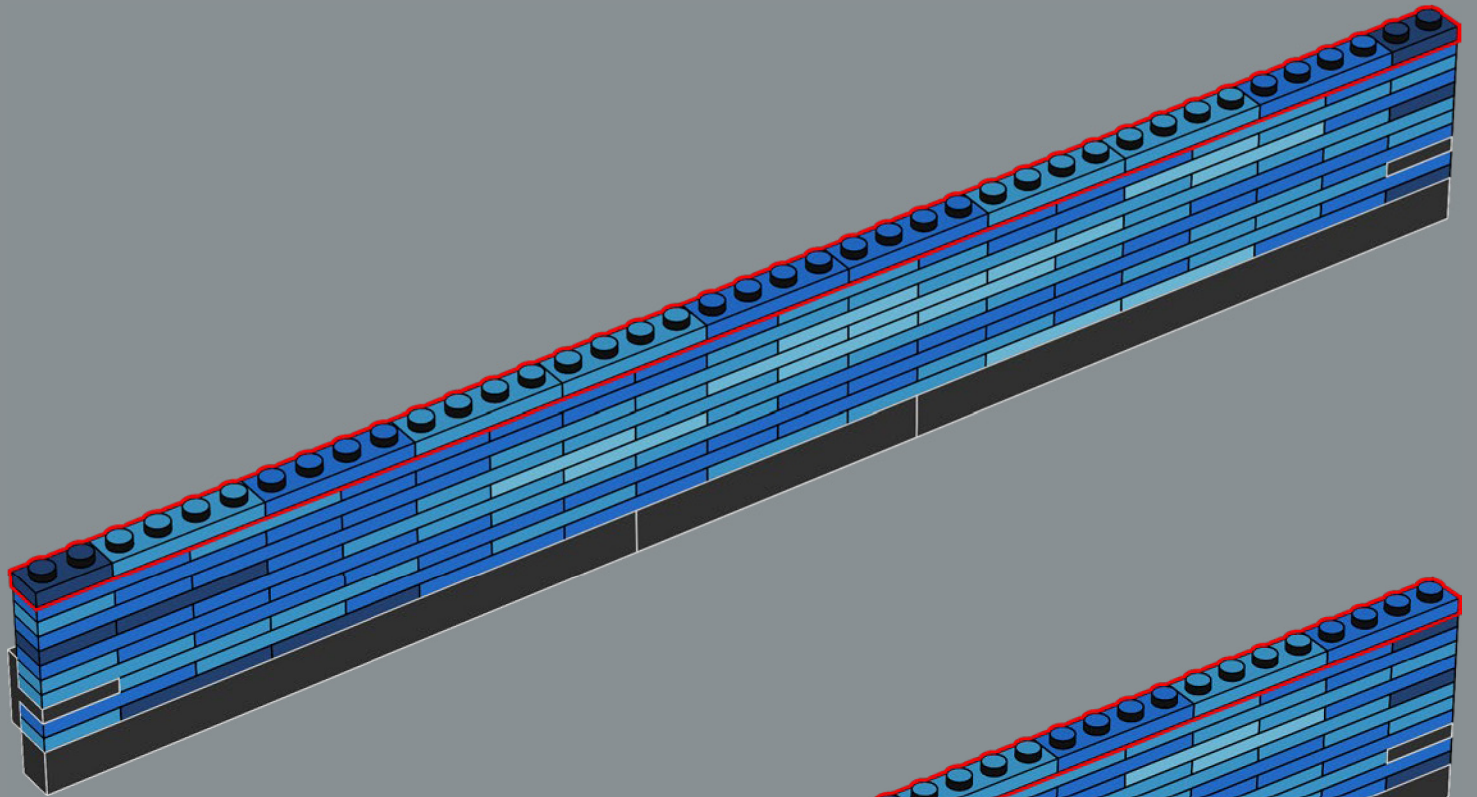

99

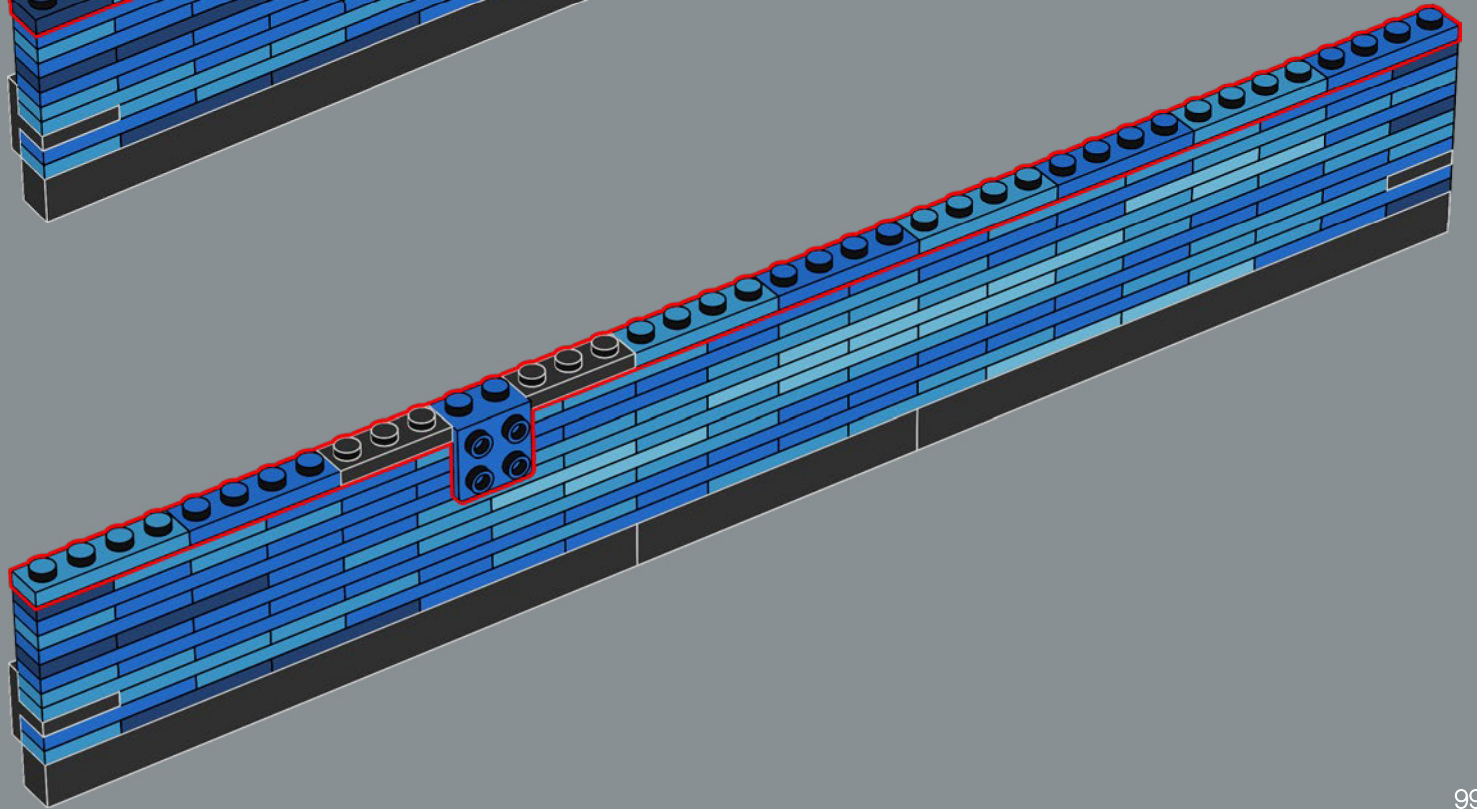

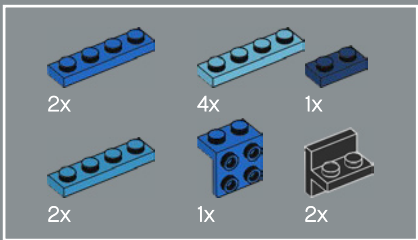

100

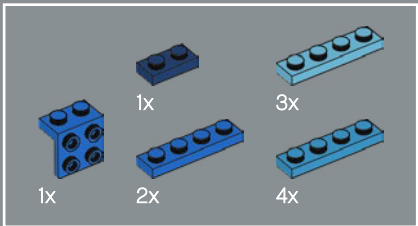
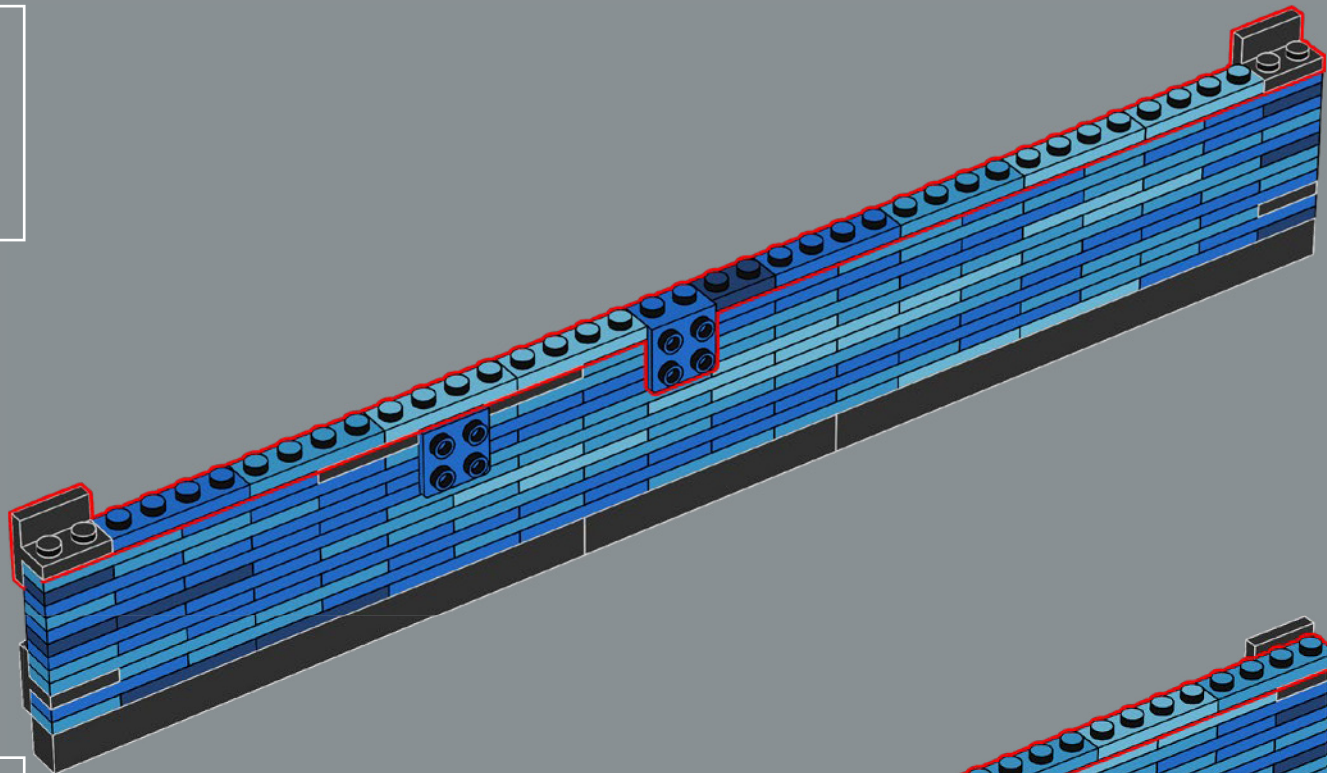

101

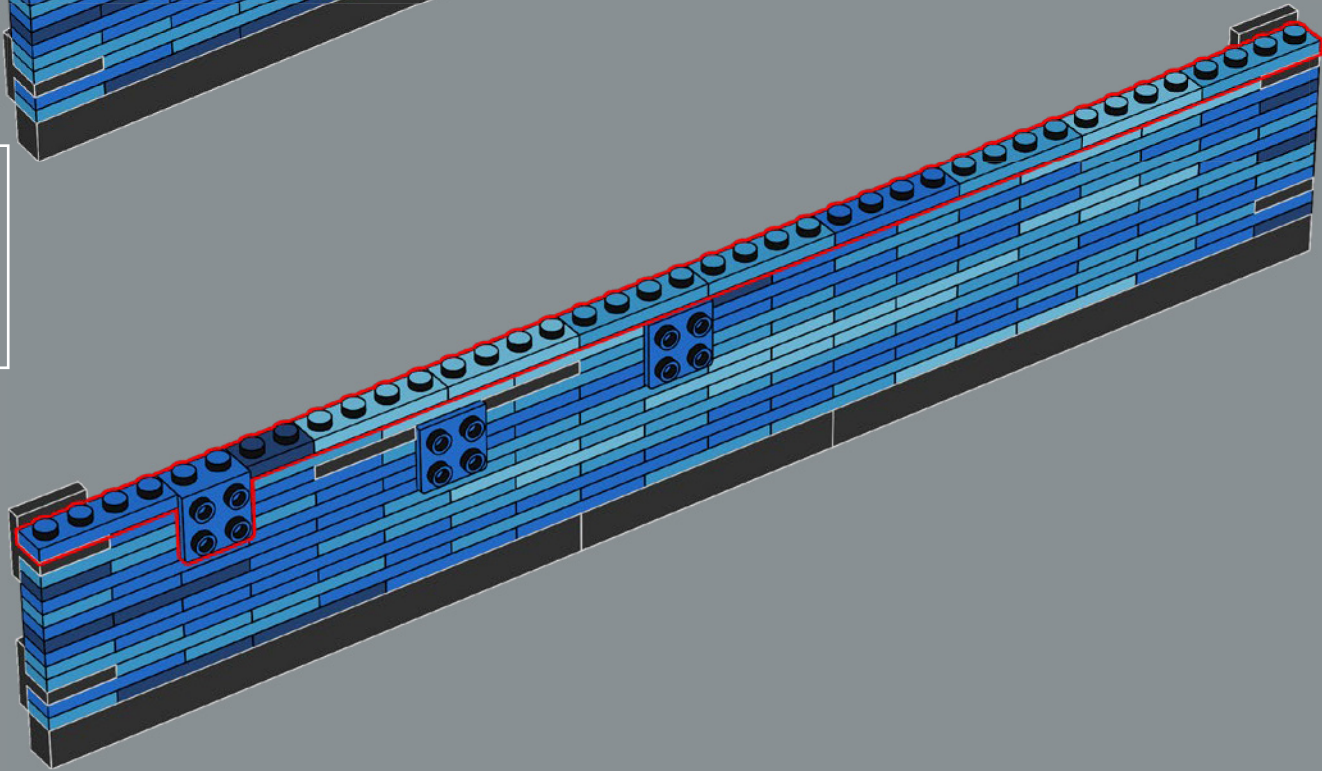

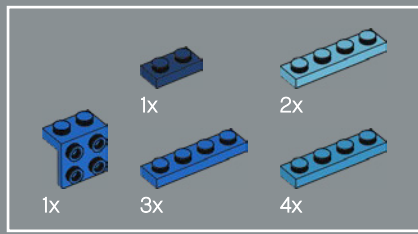

102

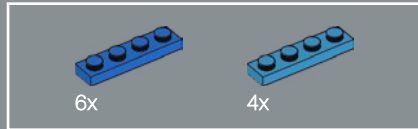
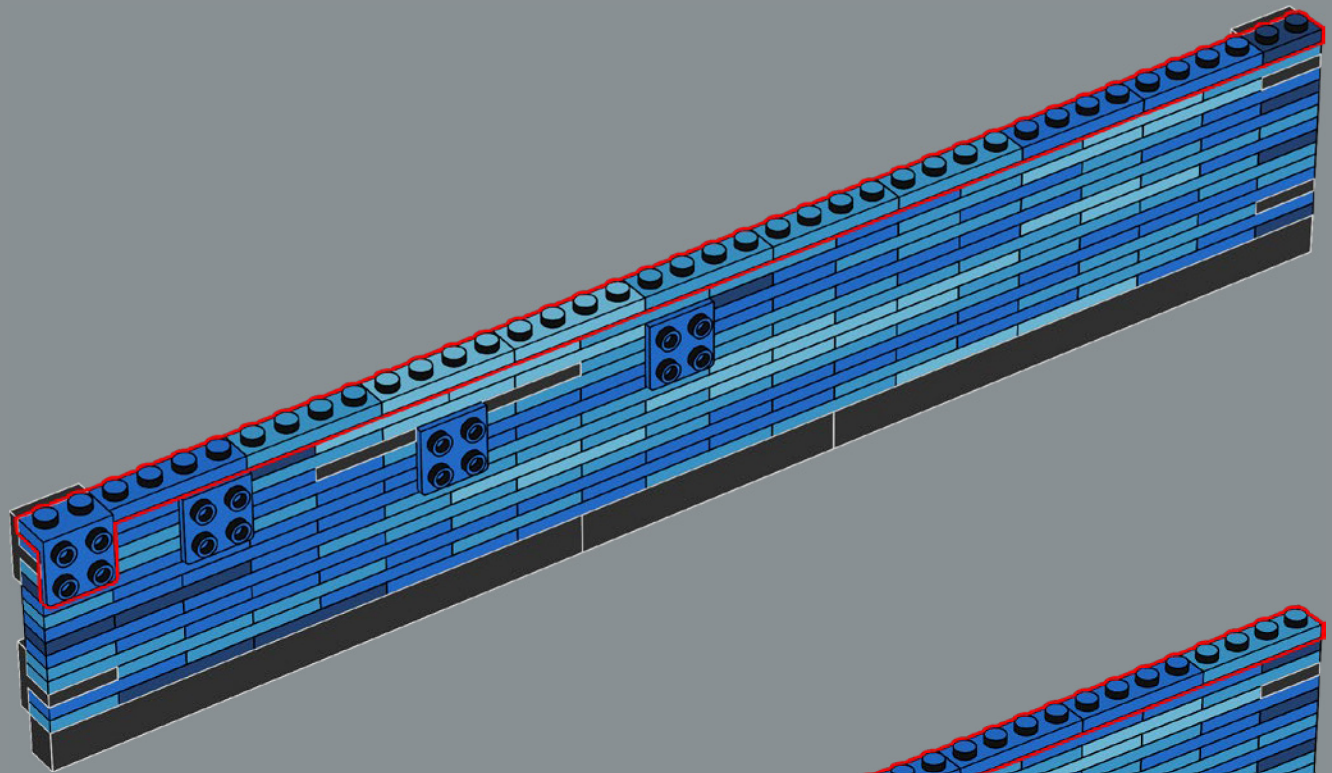

103

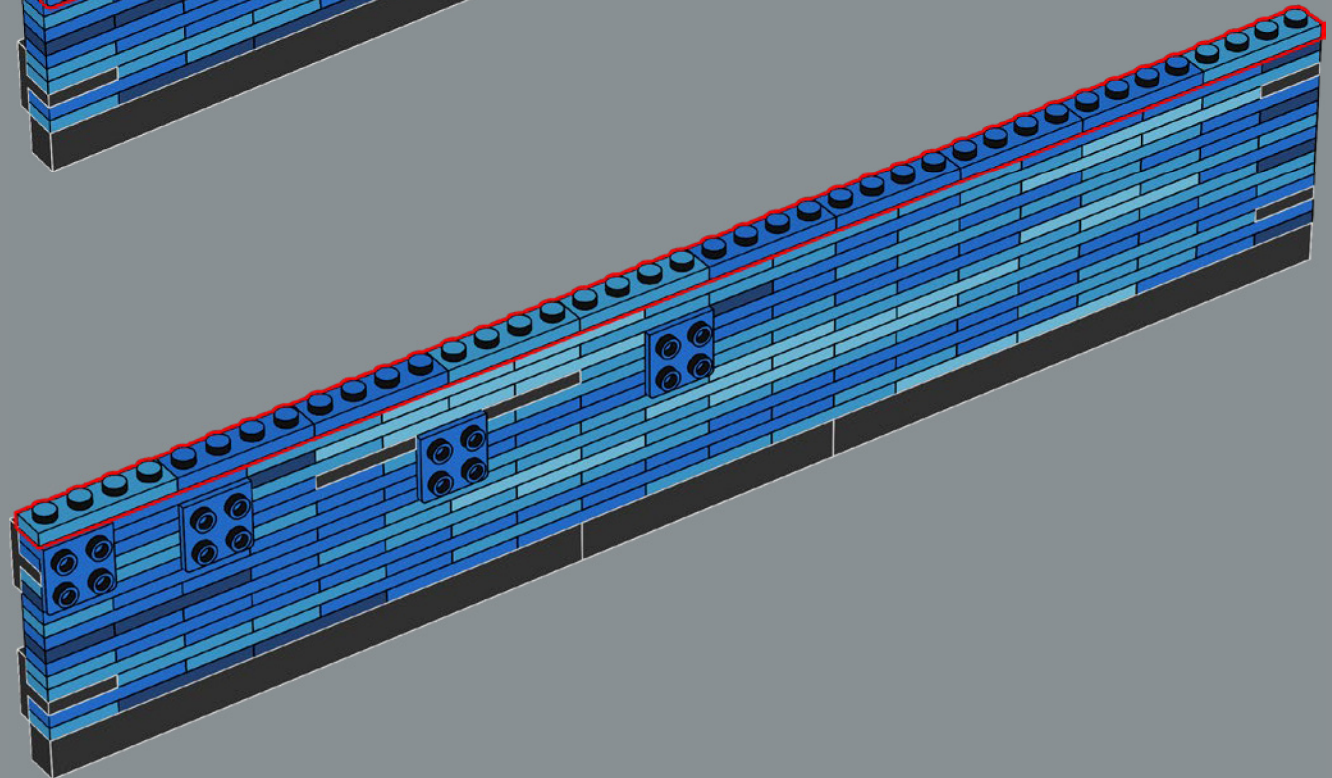

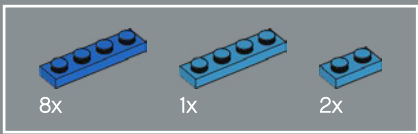

104

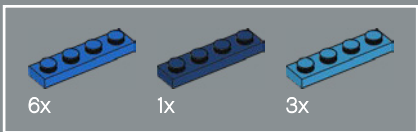
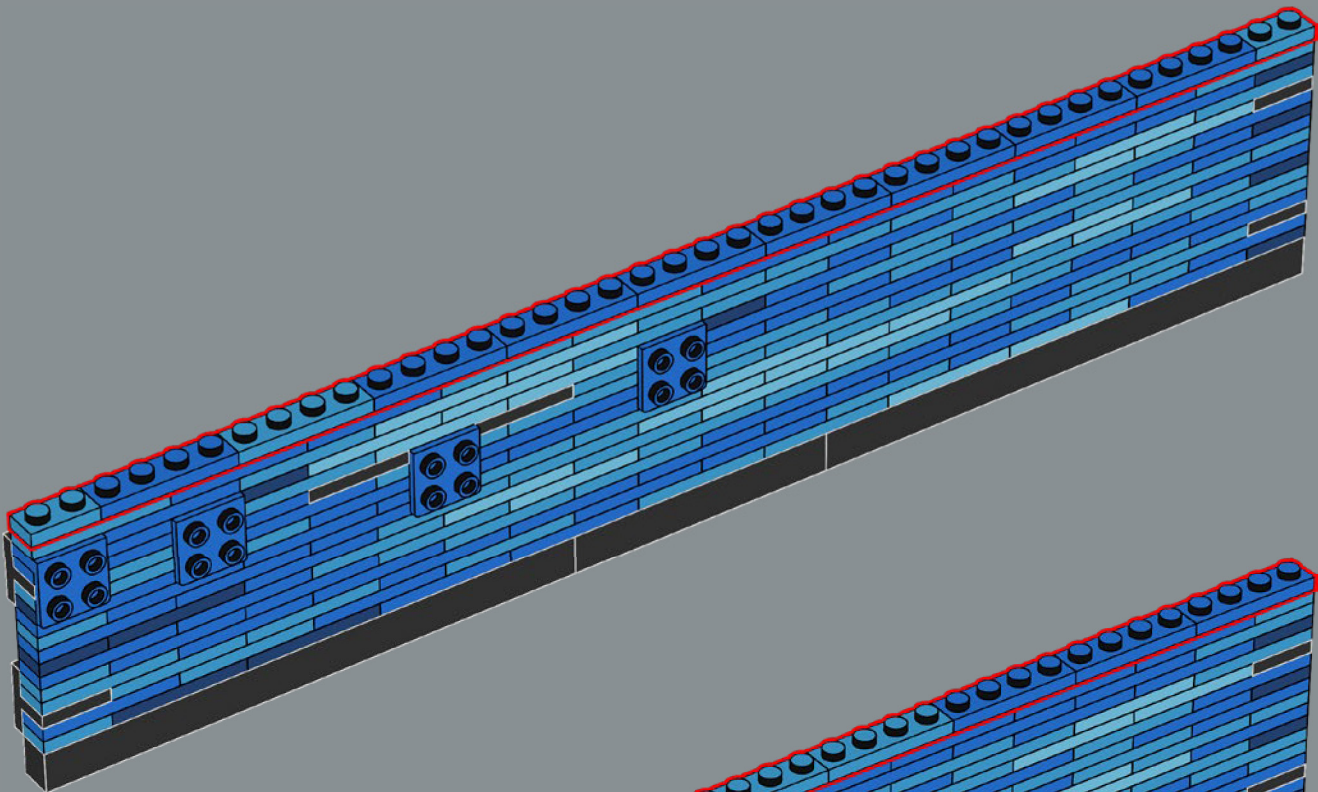

105

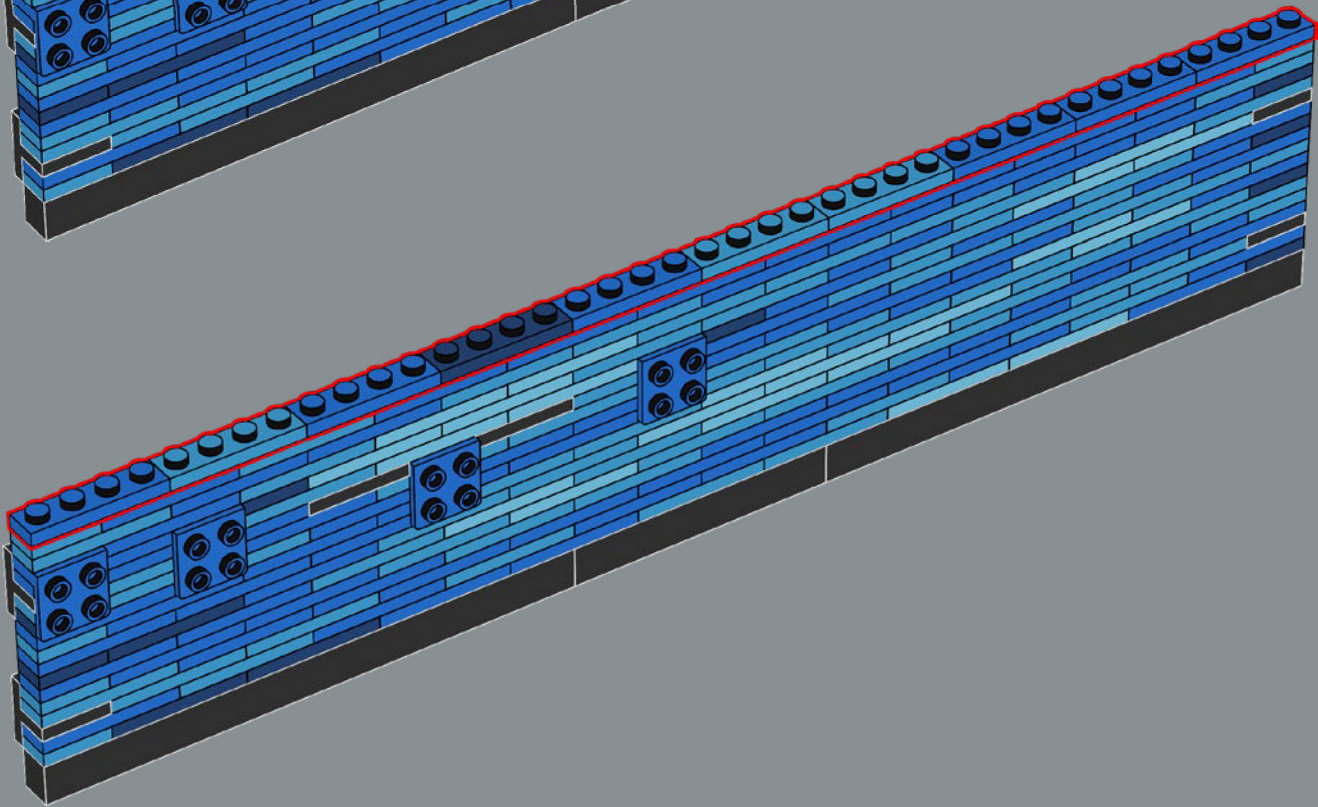

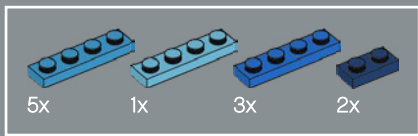

106

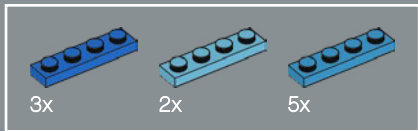
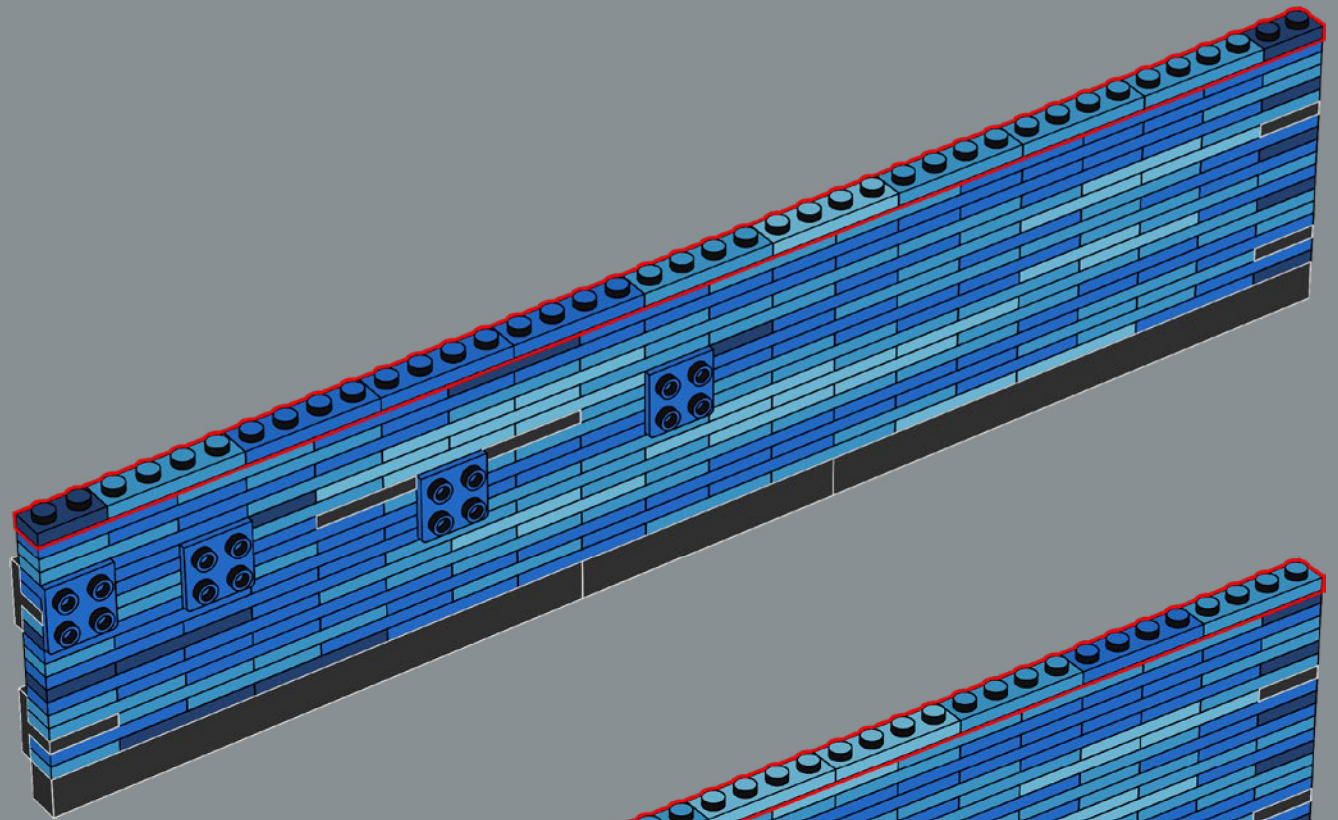

107

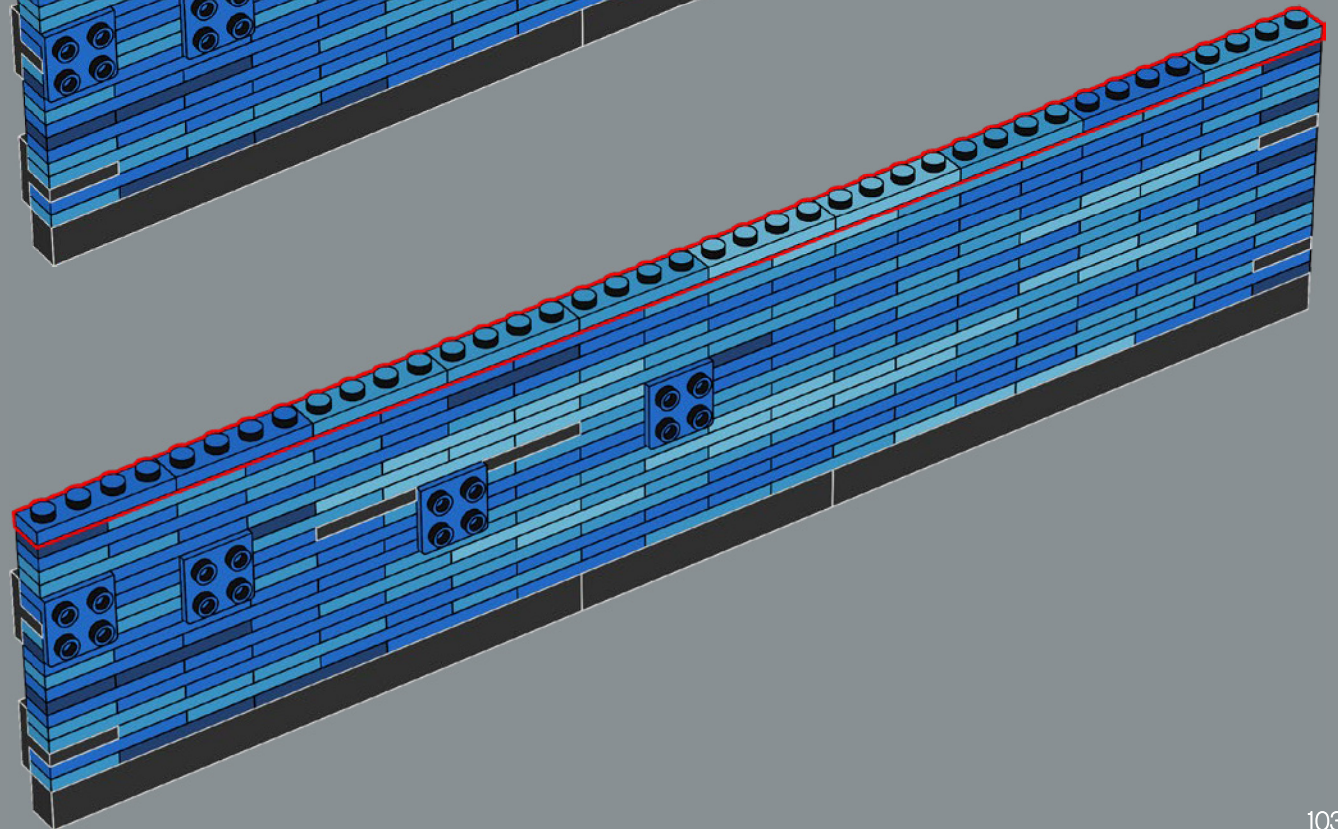

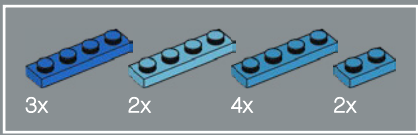

108

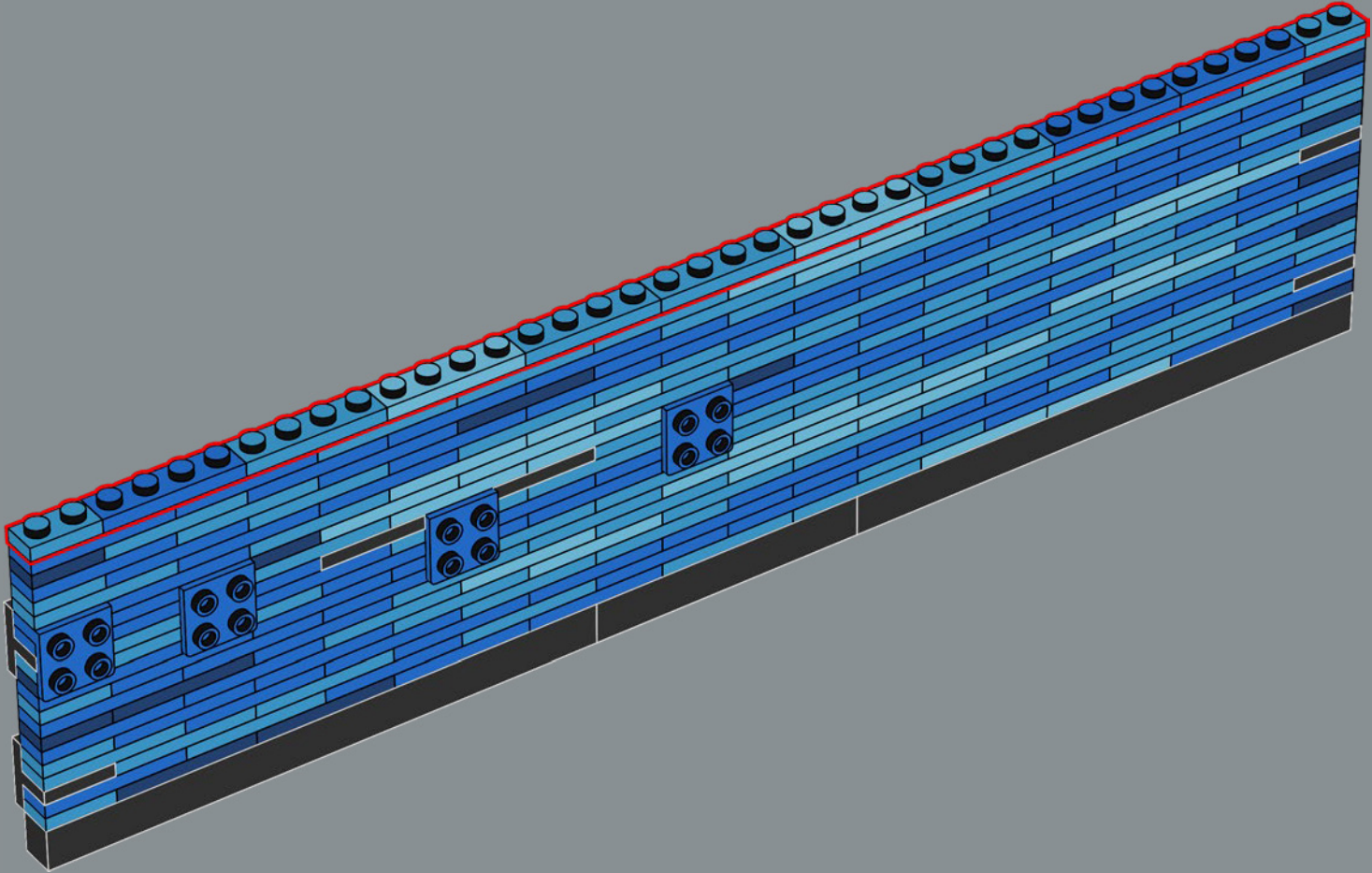

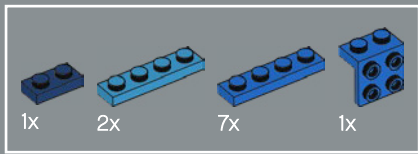

109

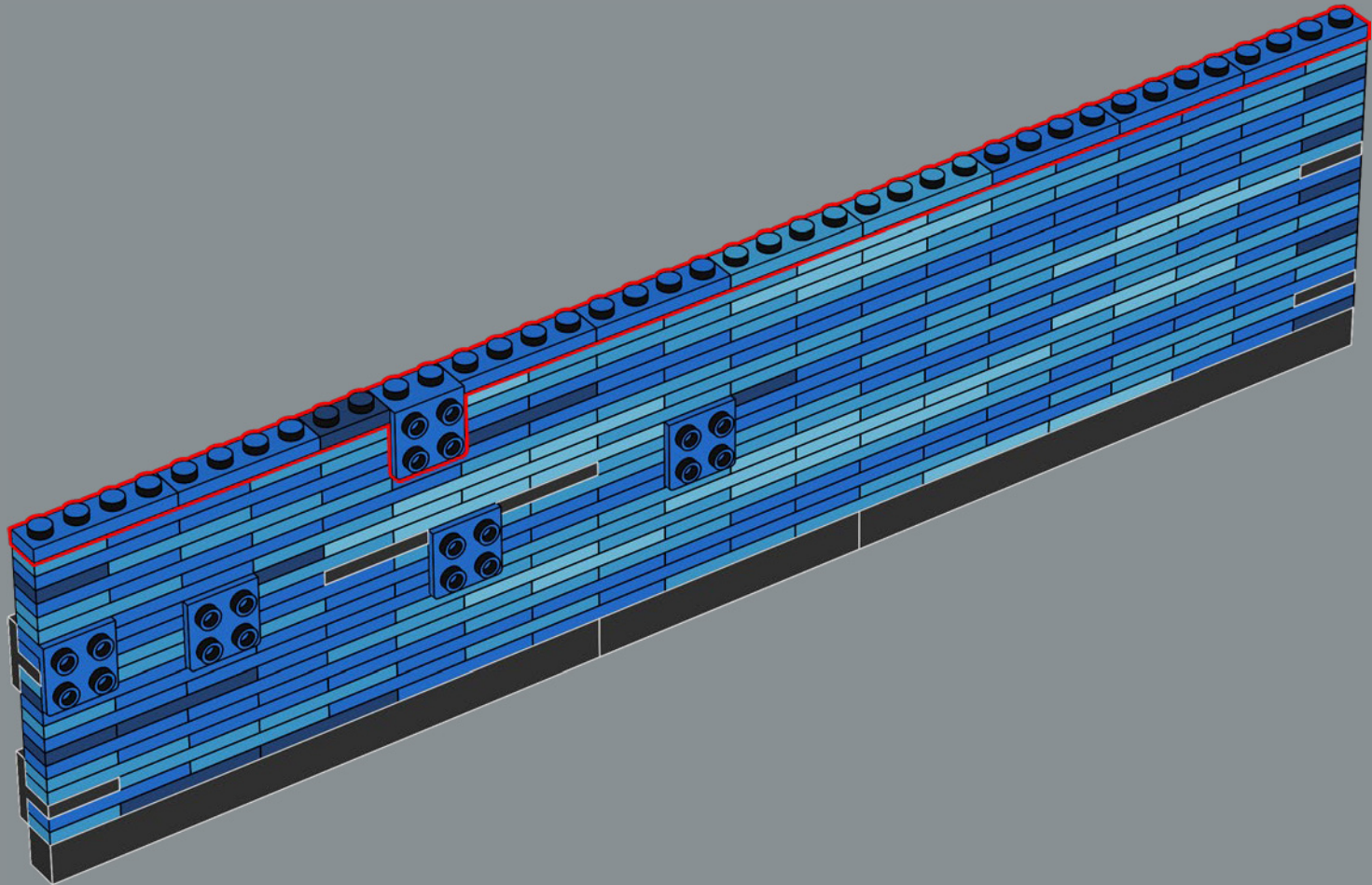

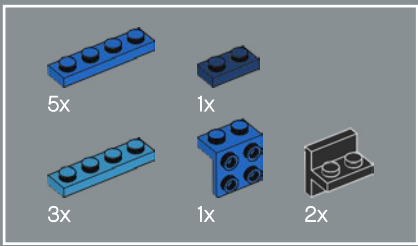

110

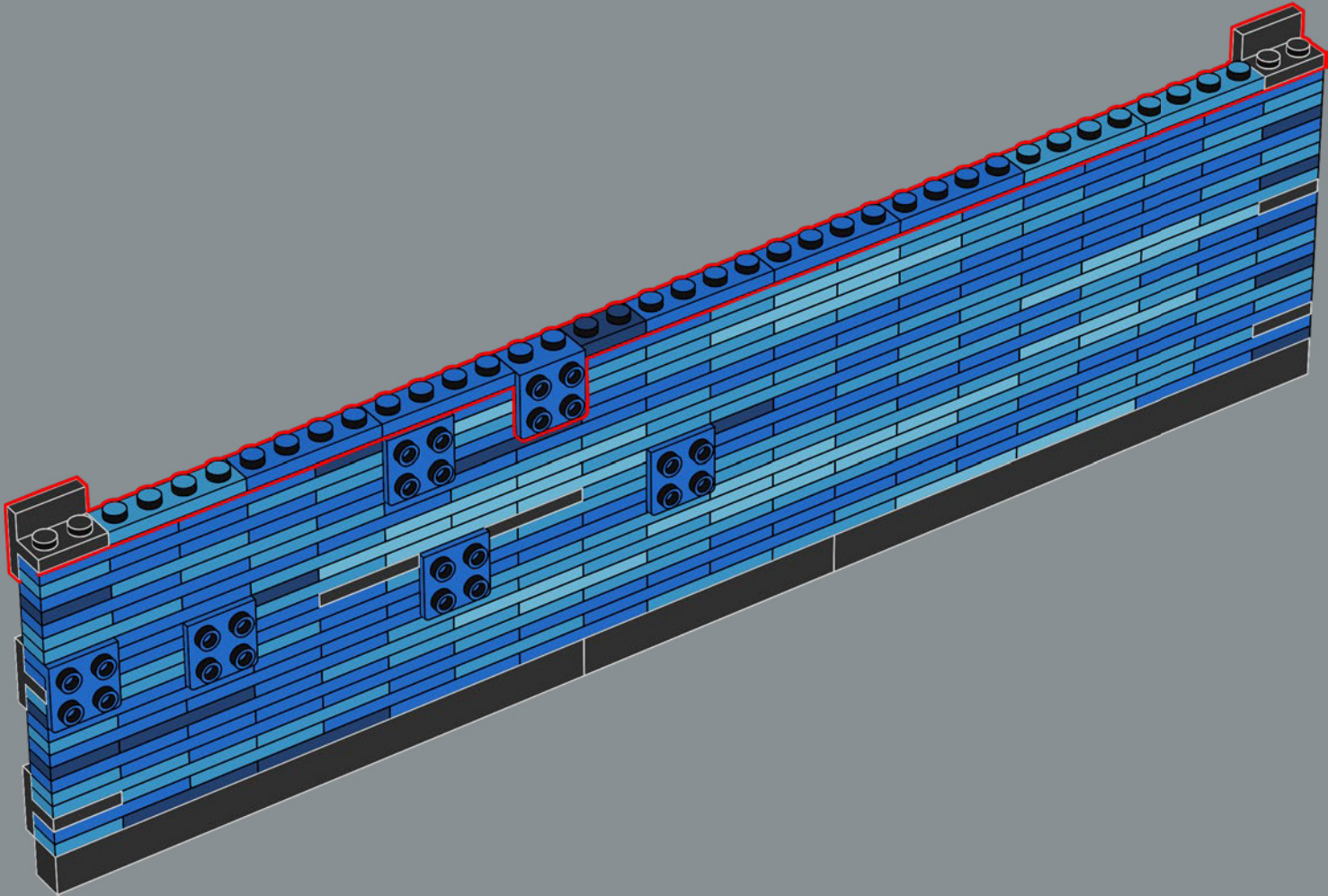

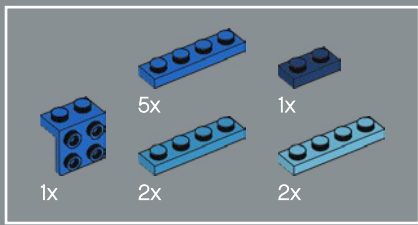

111

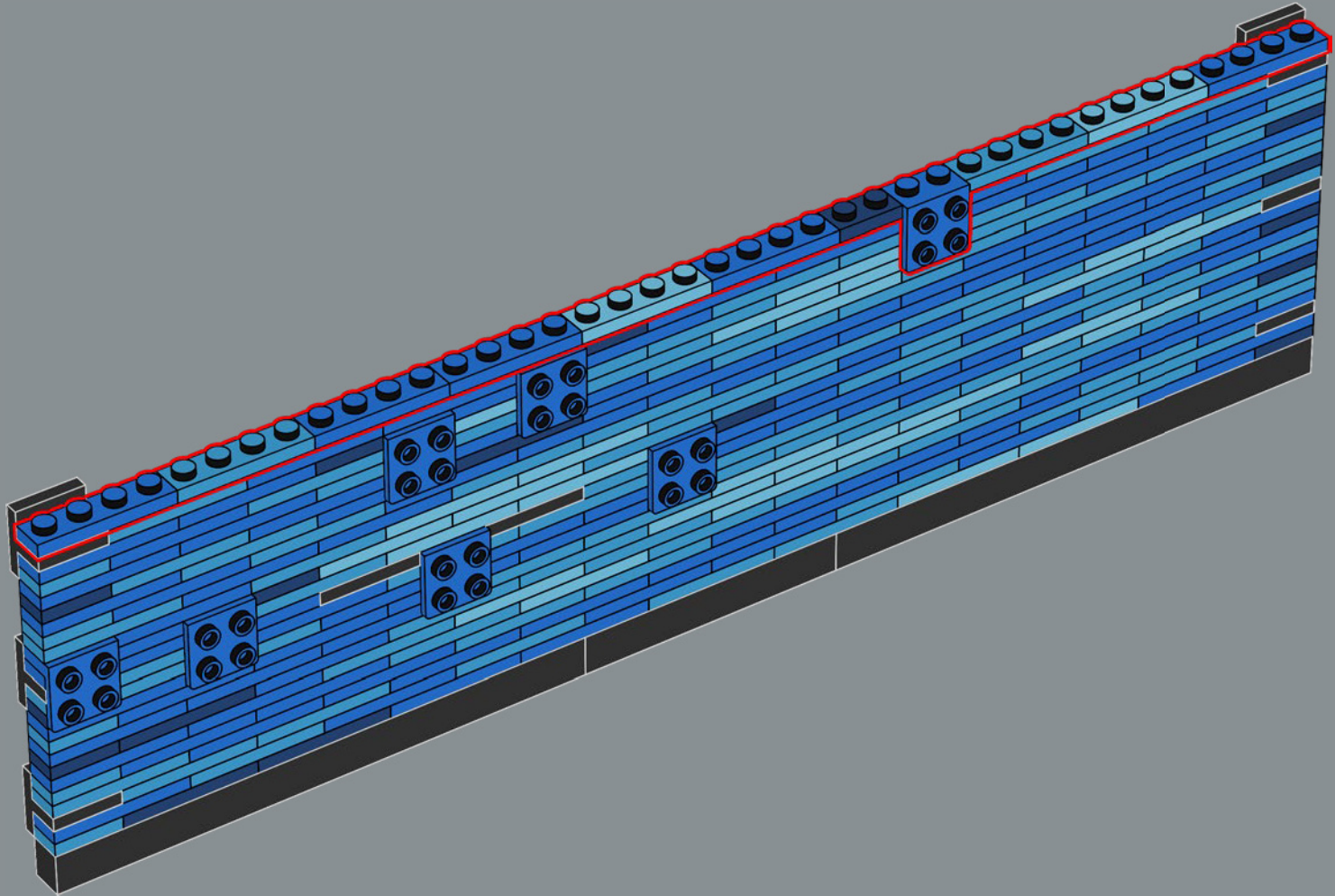

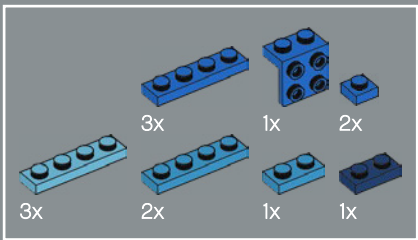

112

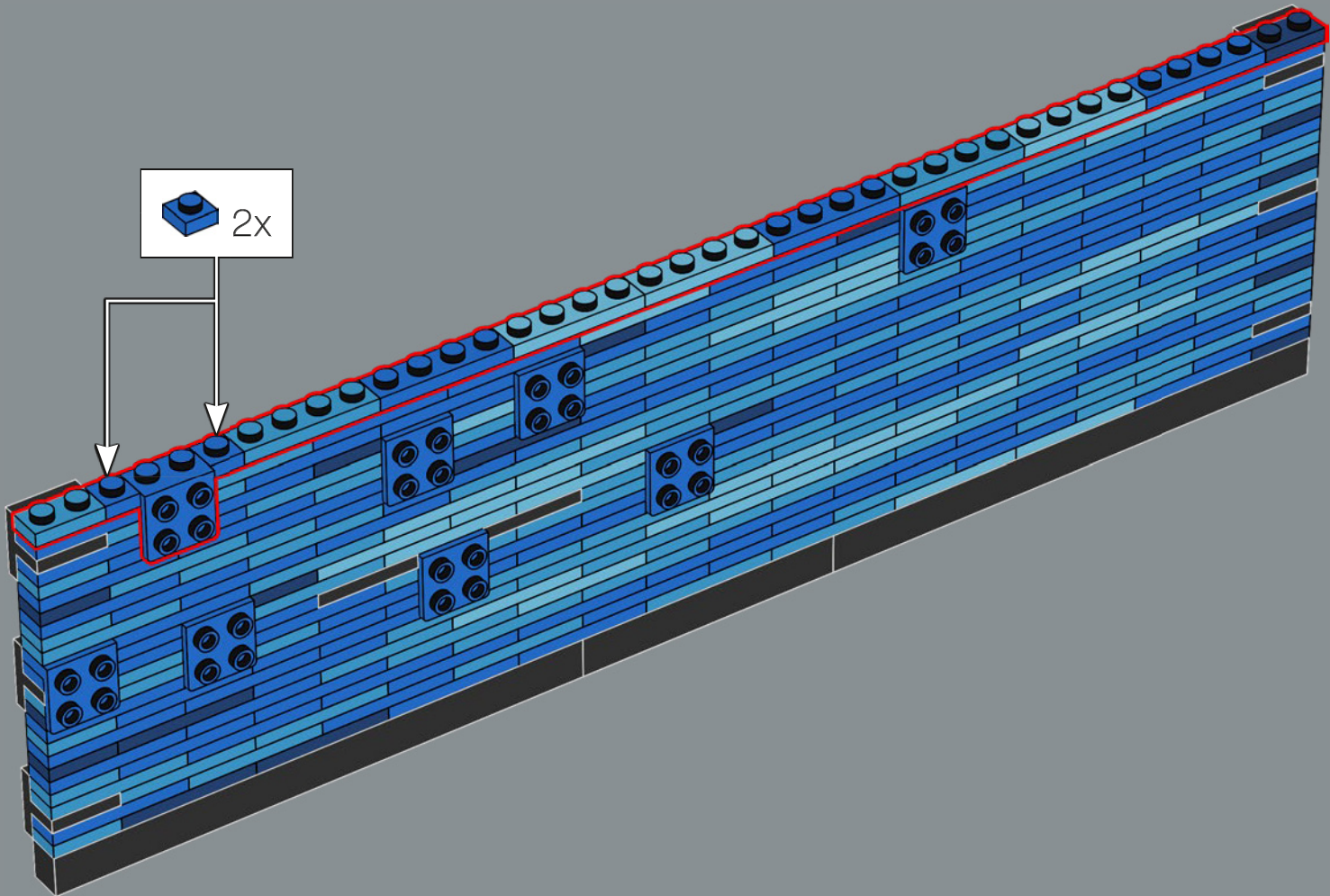

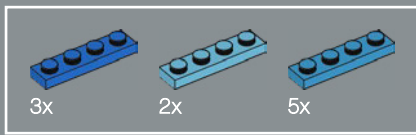

113

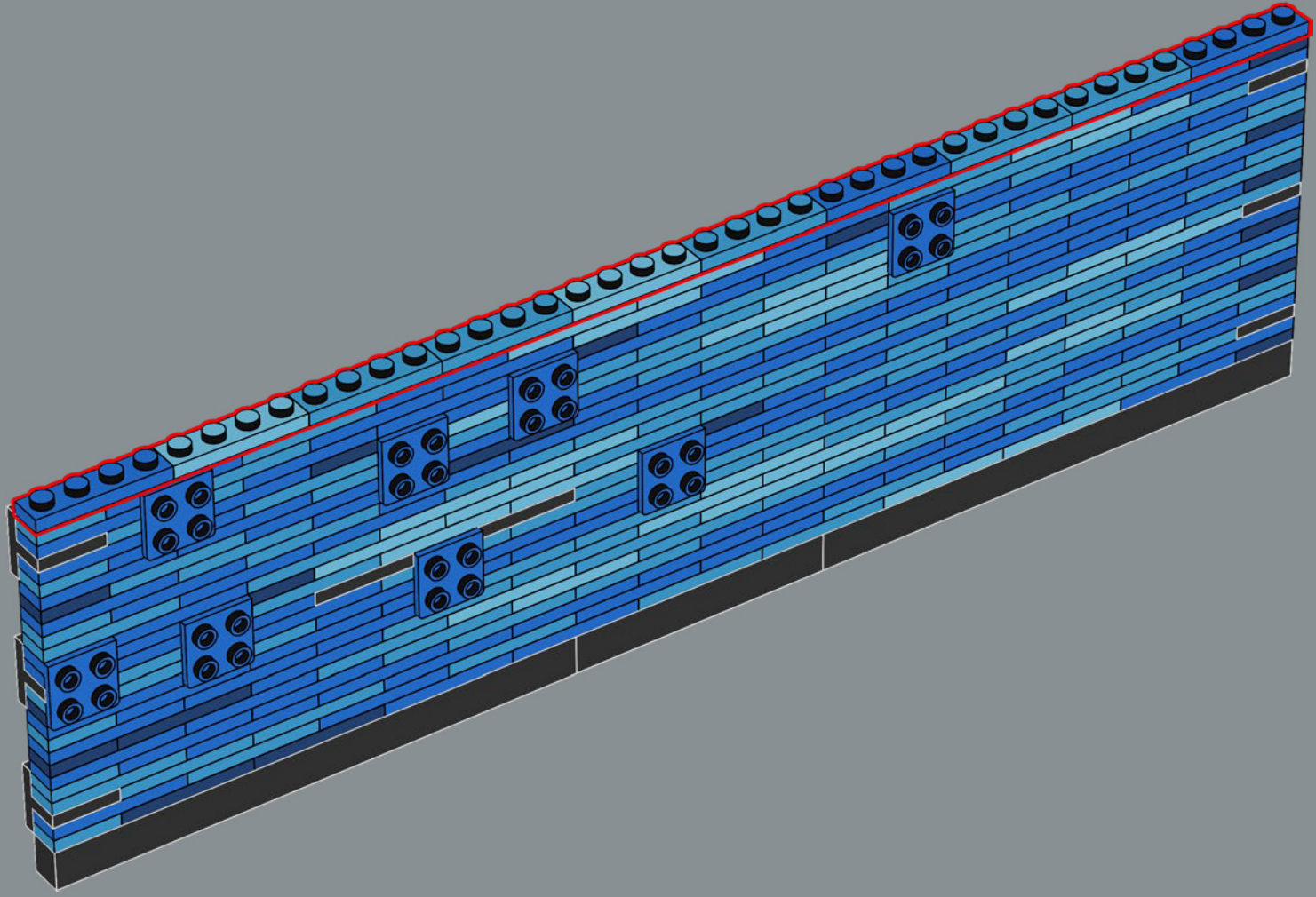

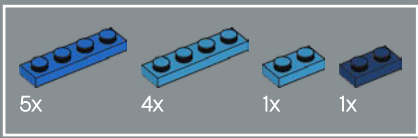

114

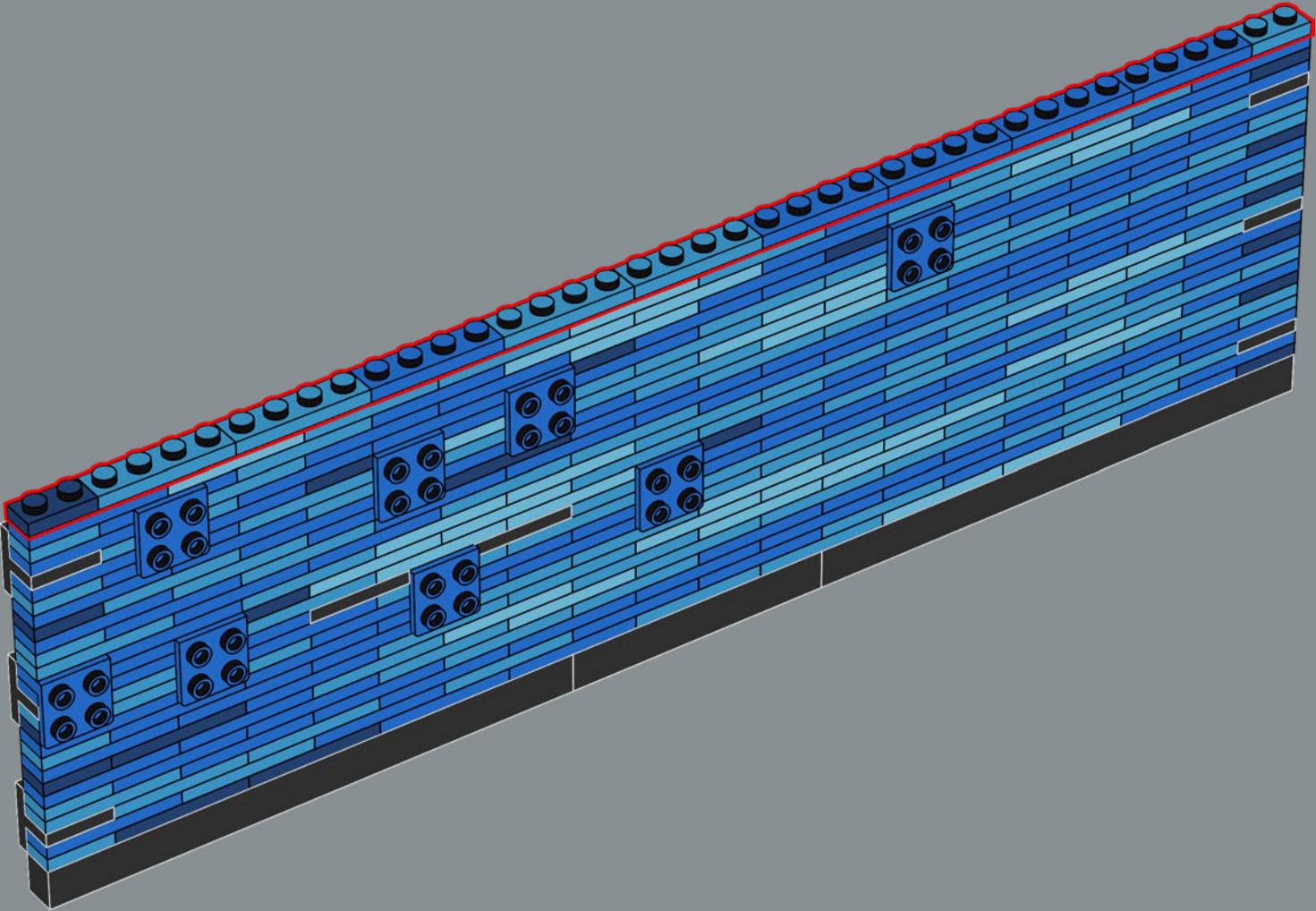

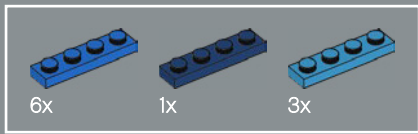

115

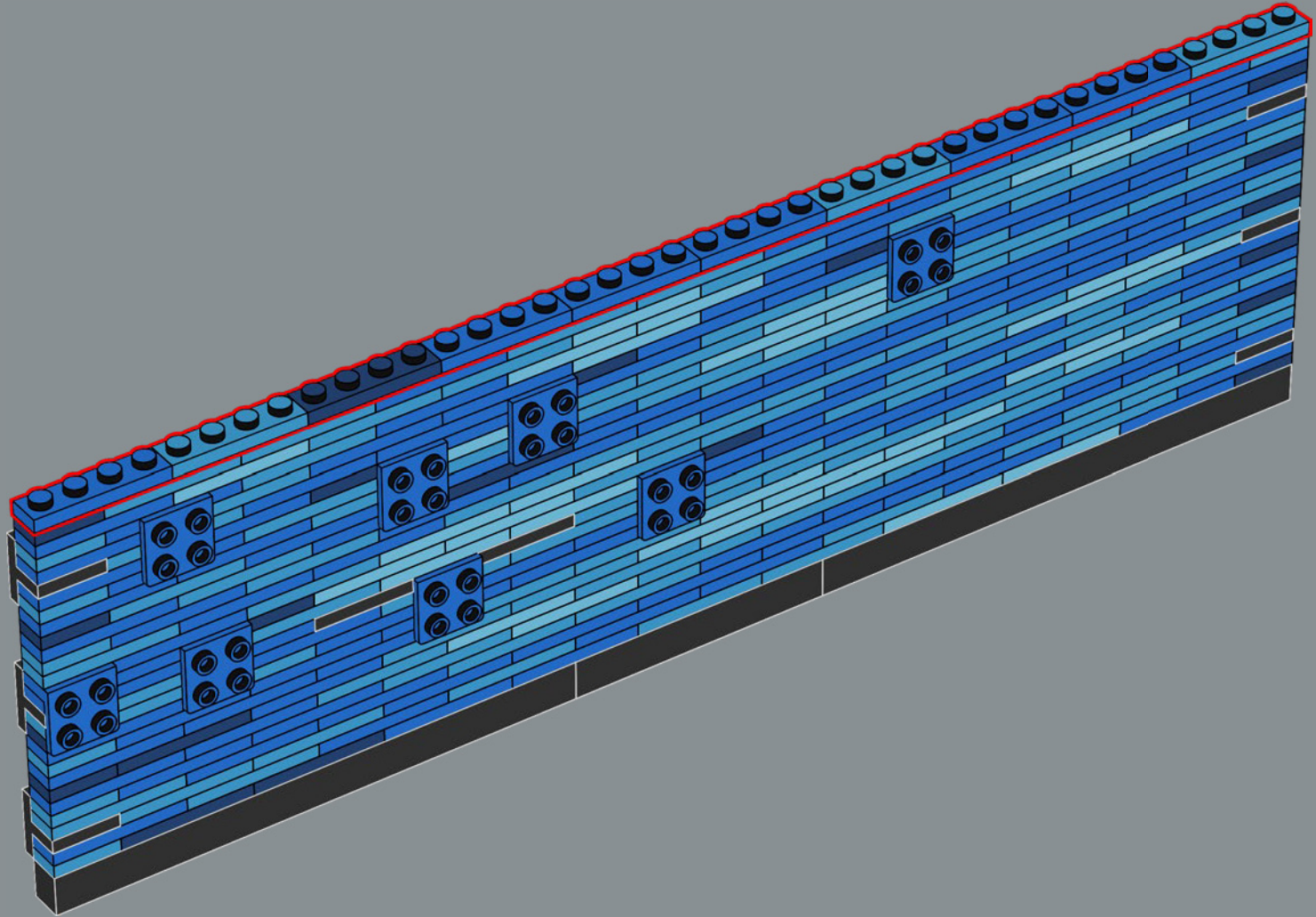

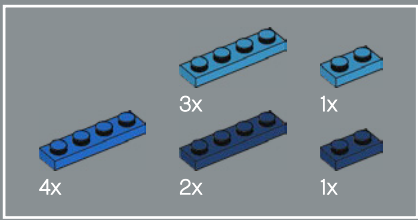

116

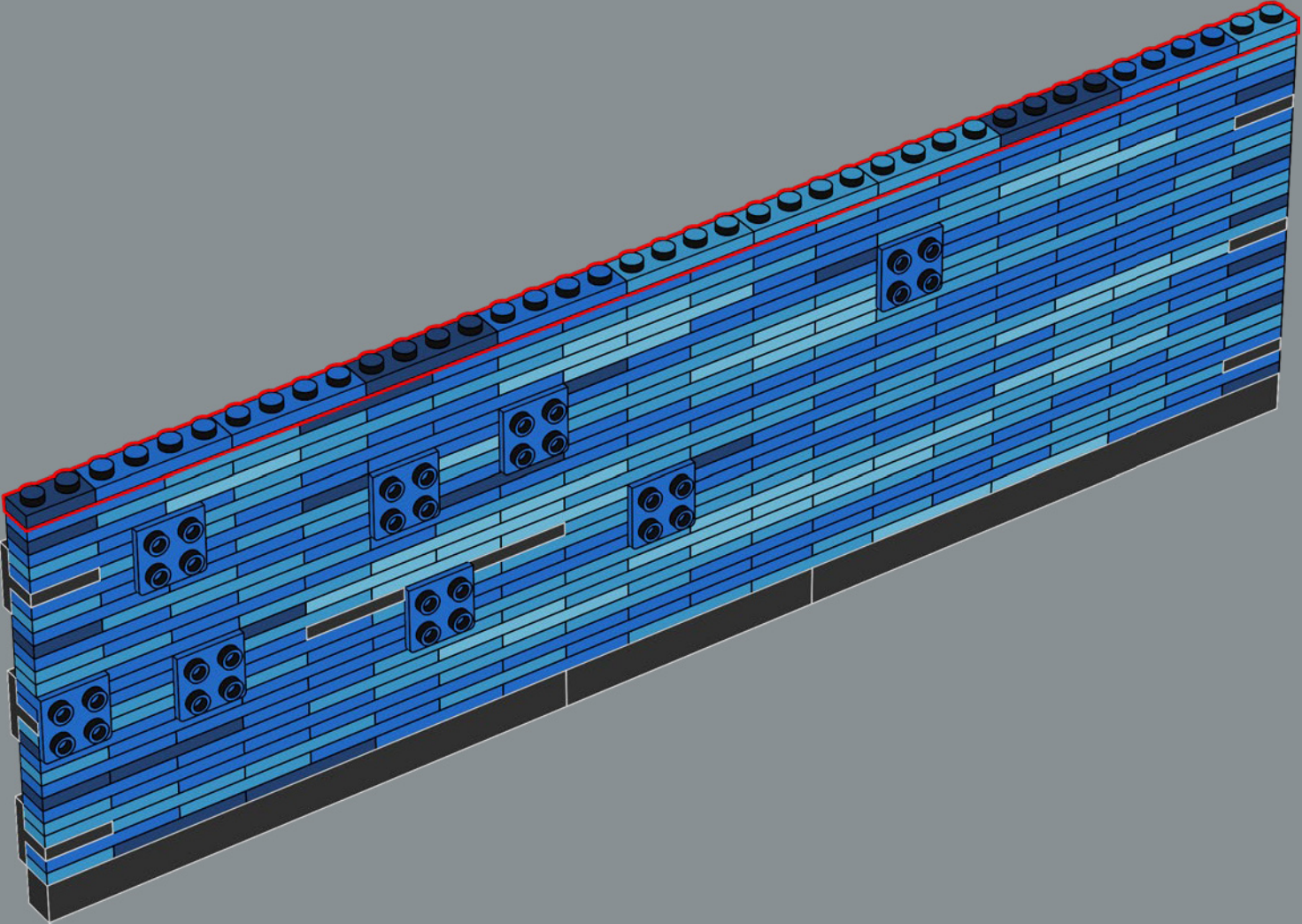

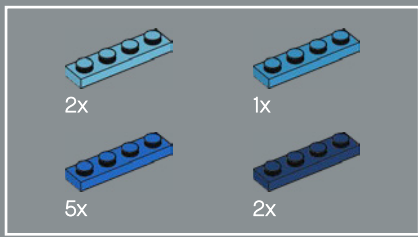

117

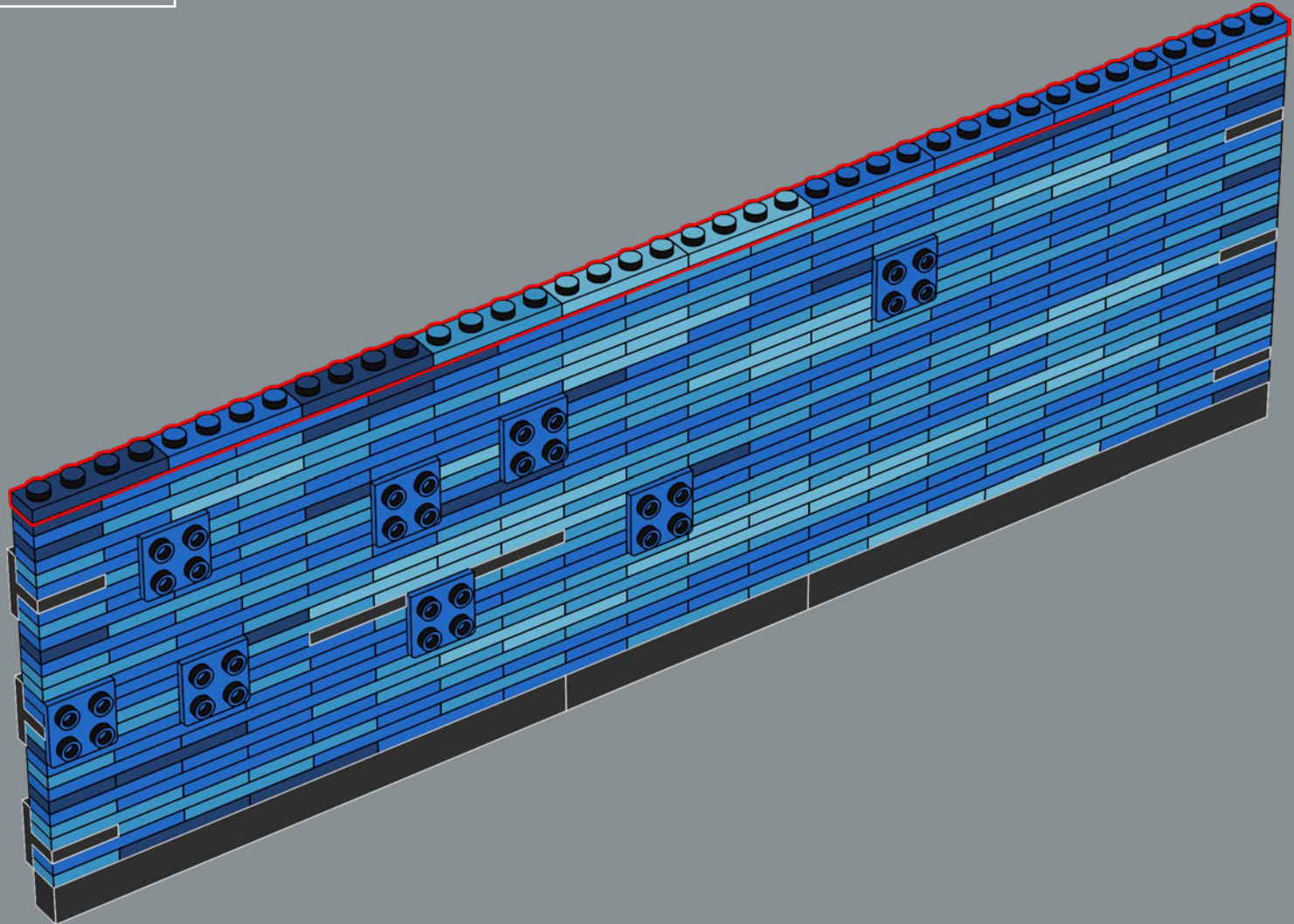

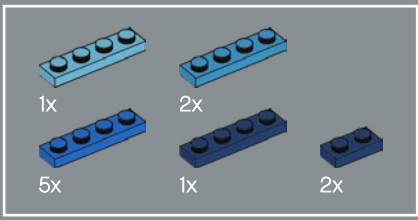

118

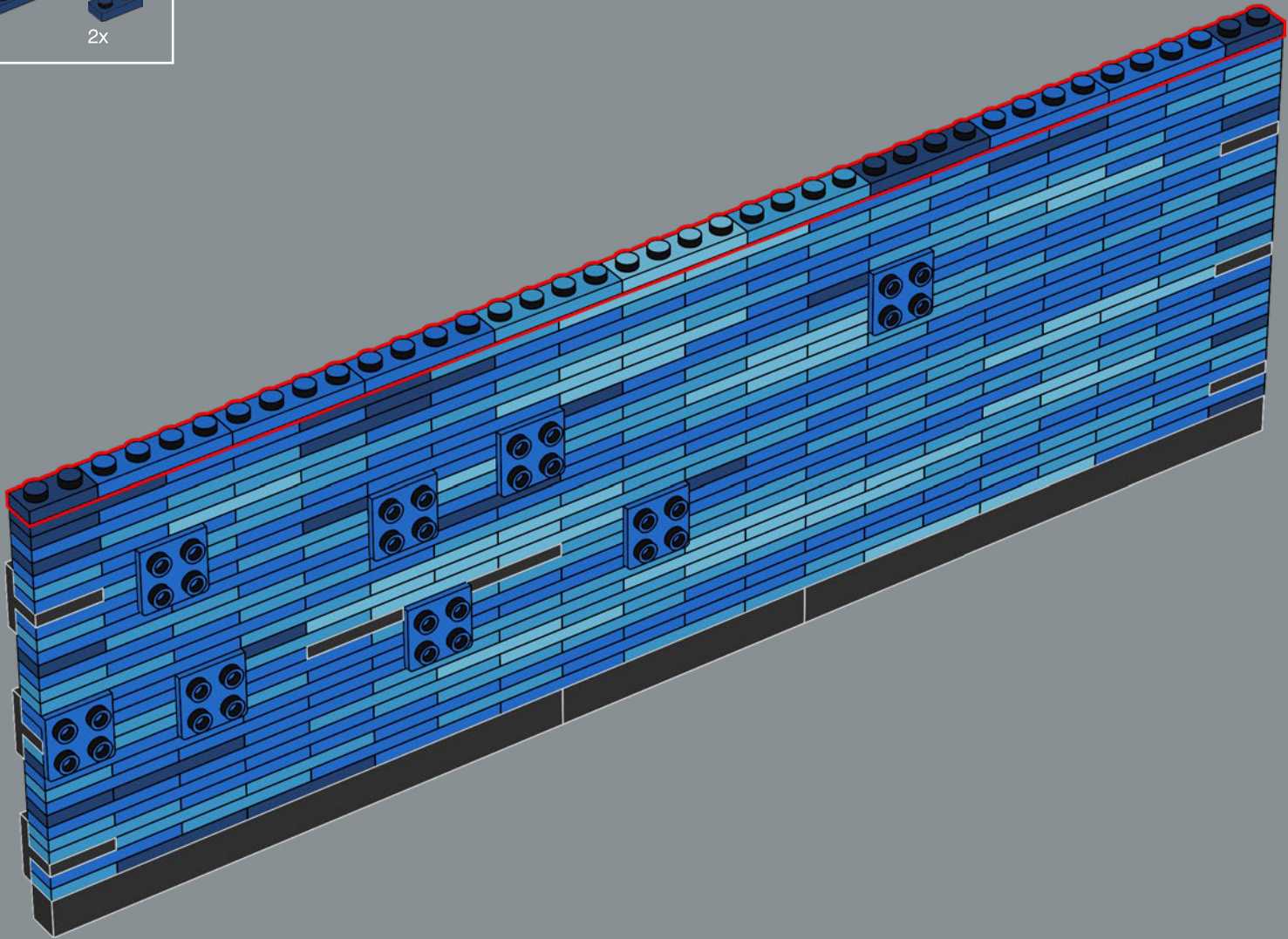

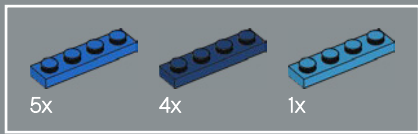

119

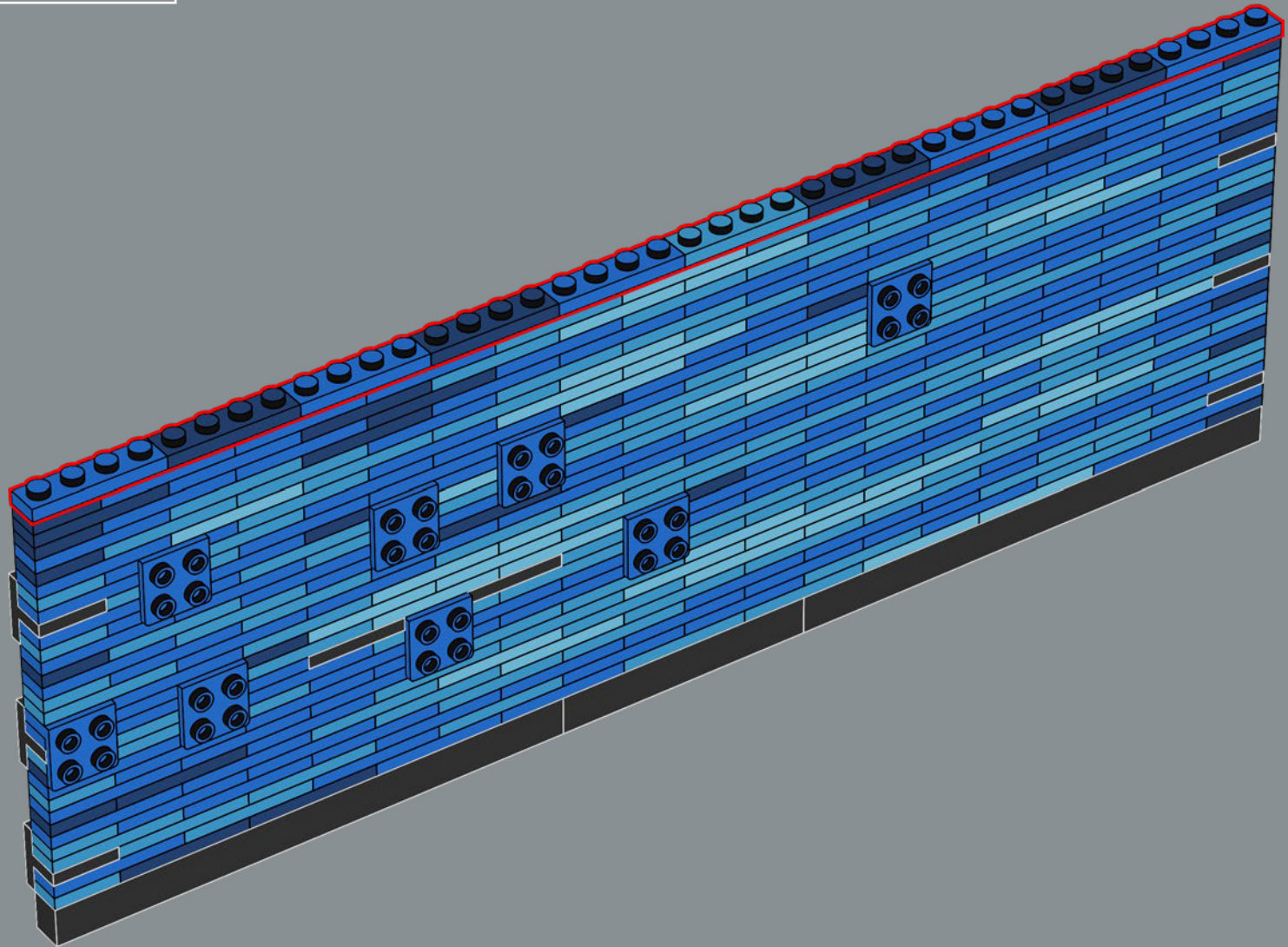

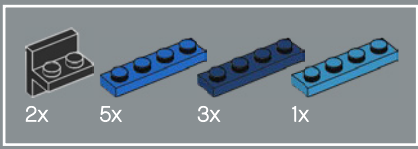

120

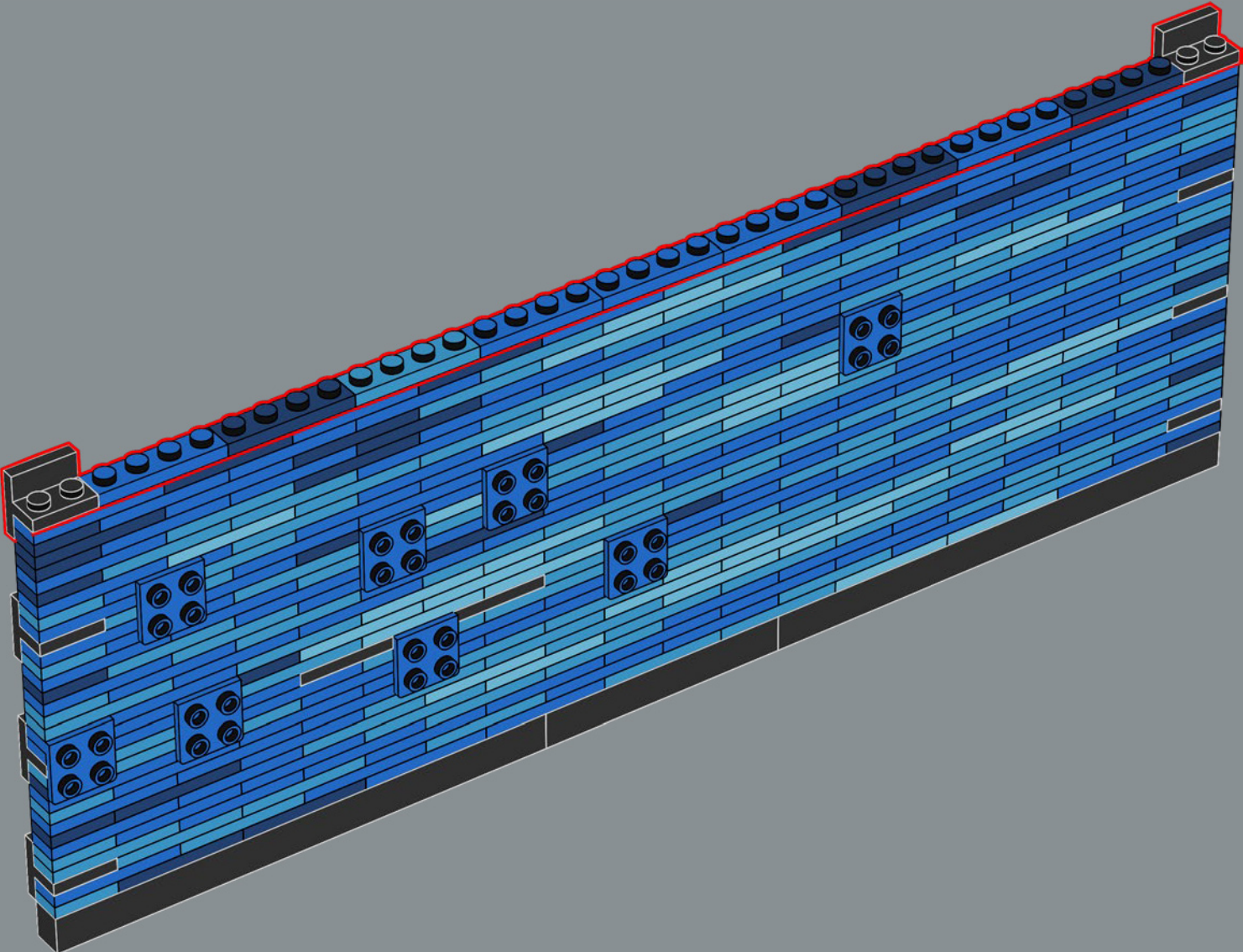

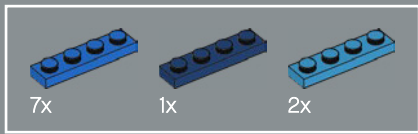

121

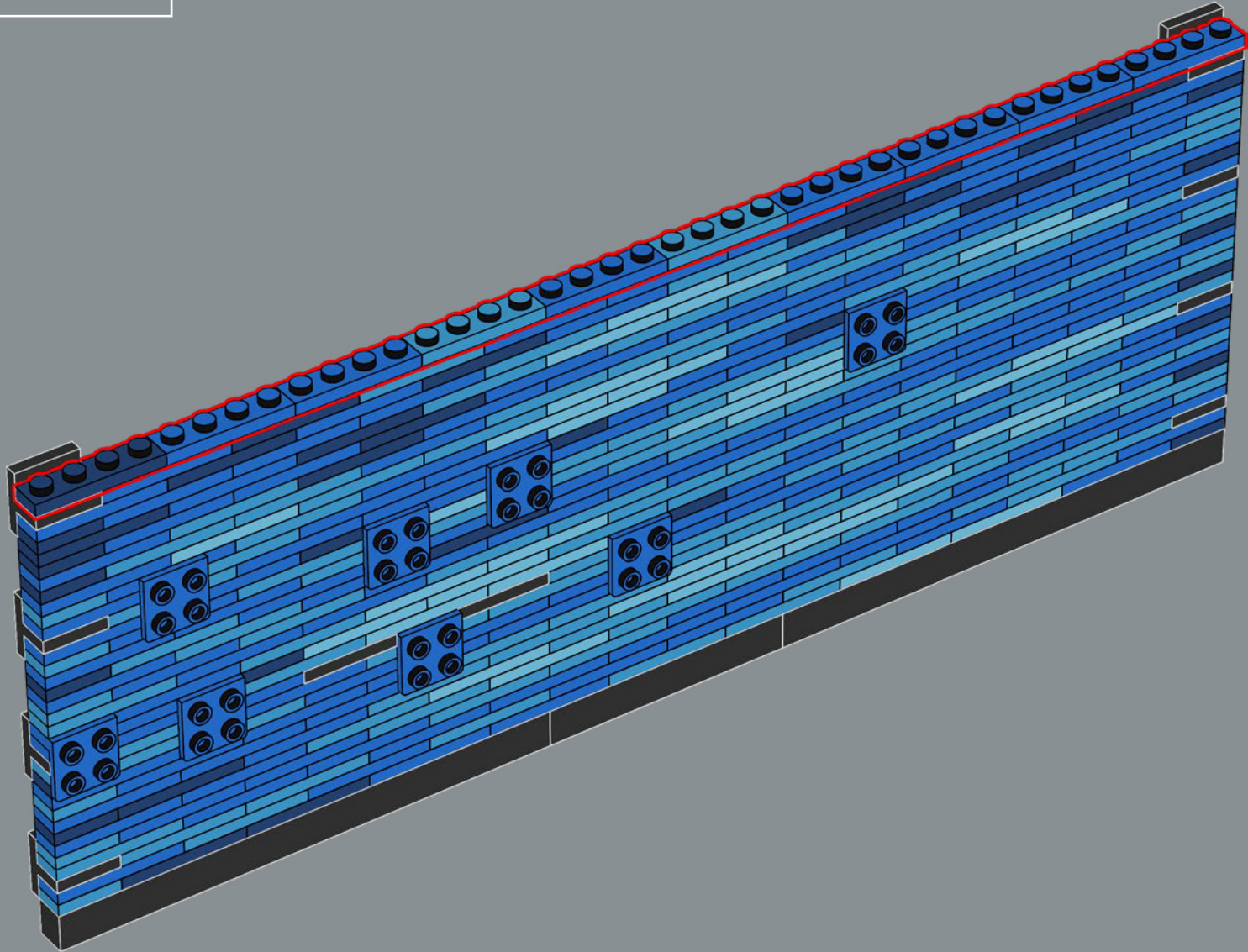

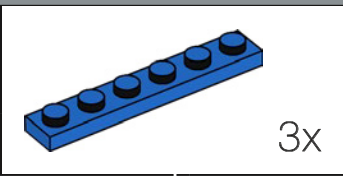
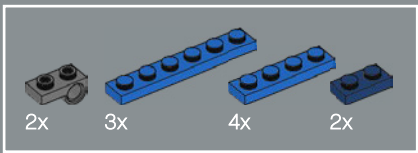

122

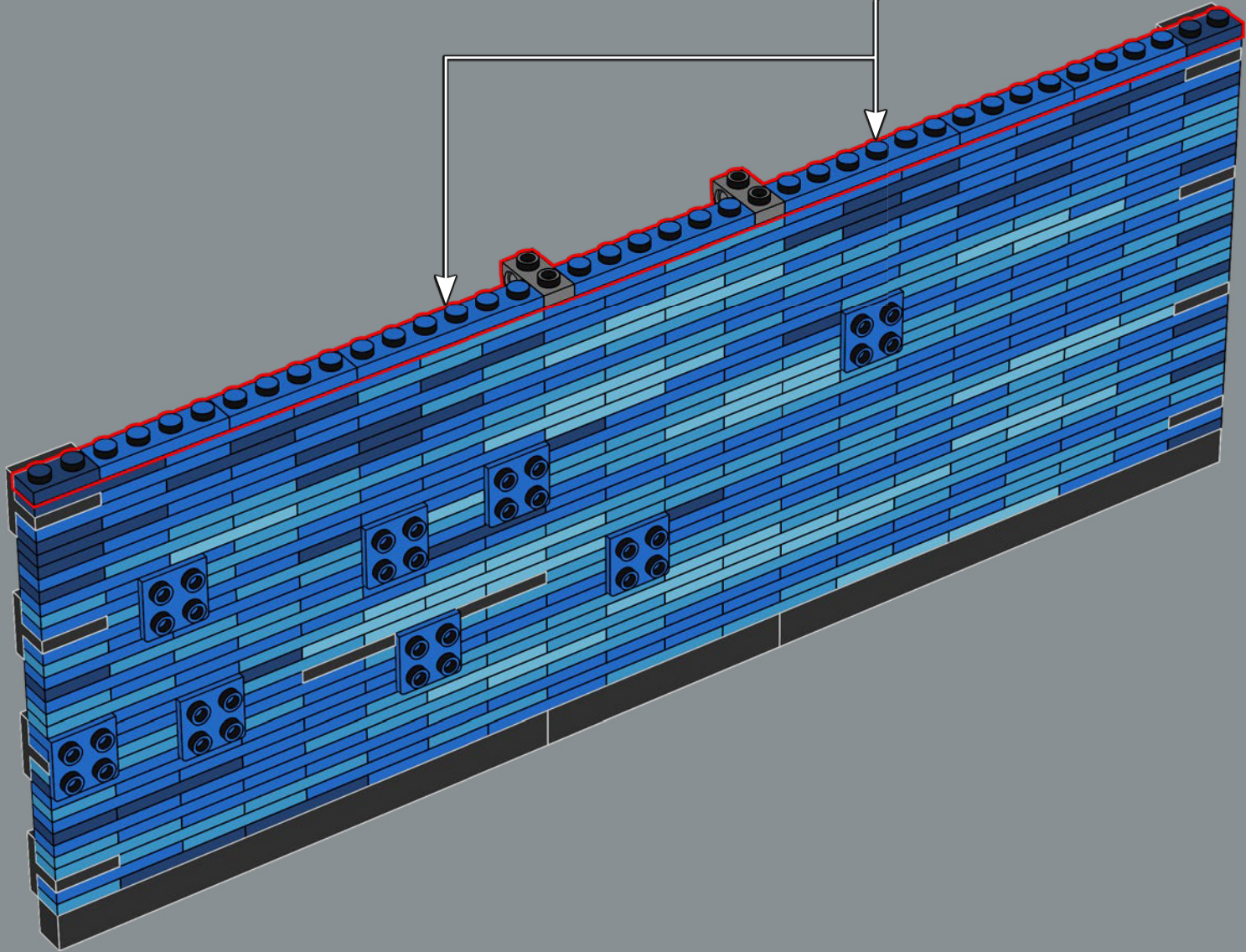

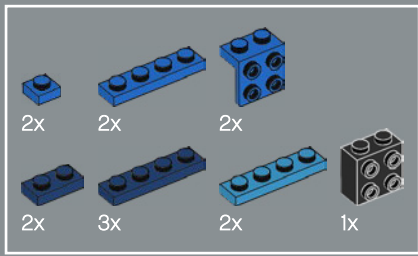

123

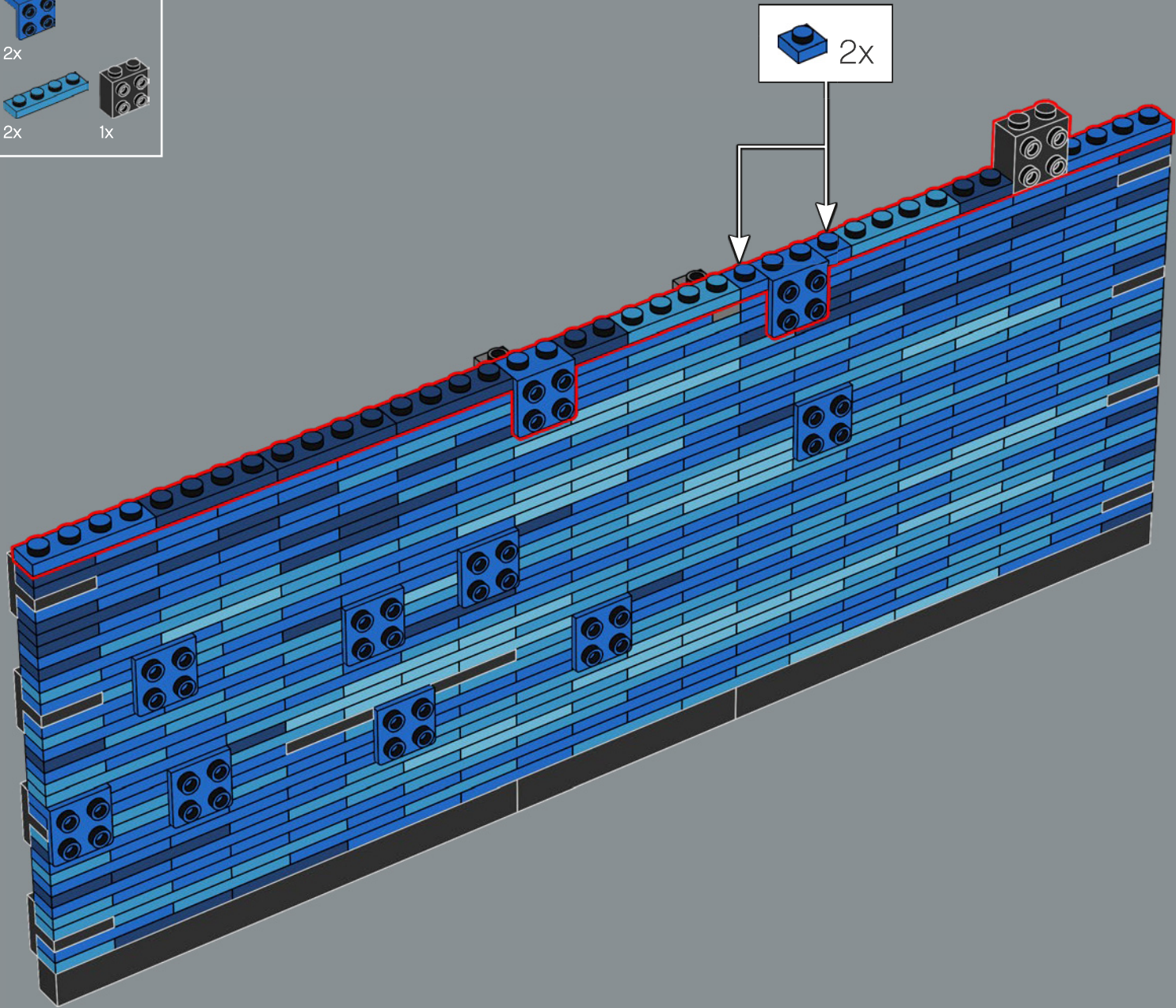

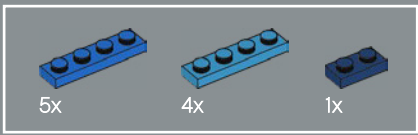

124

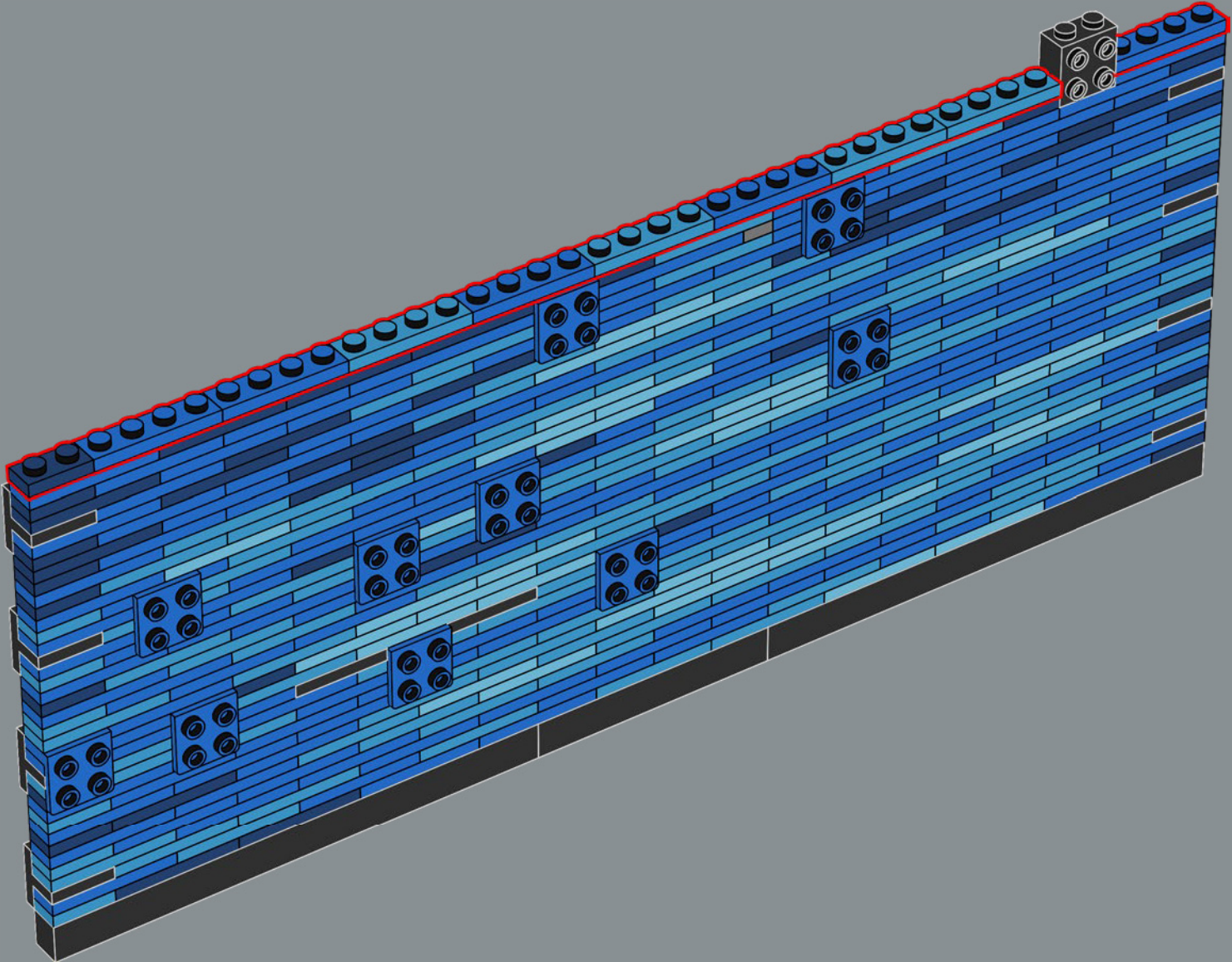

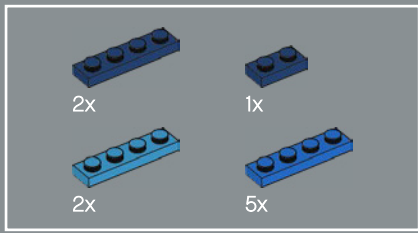

125

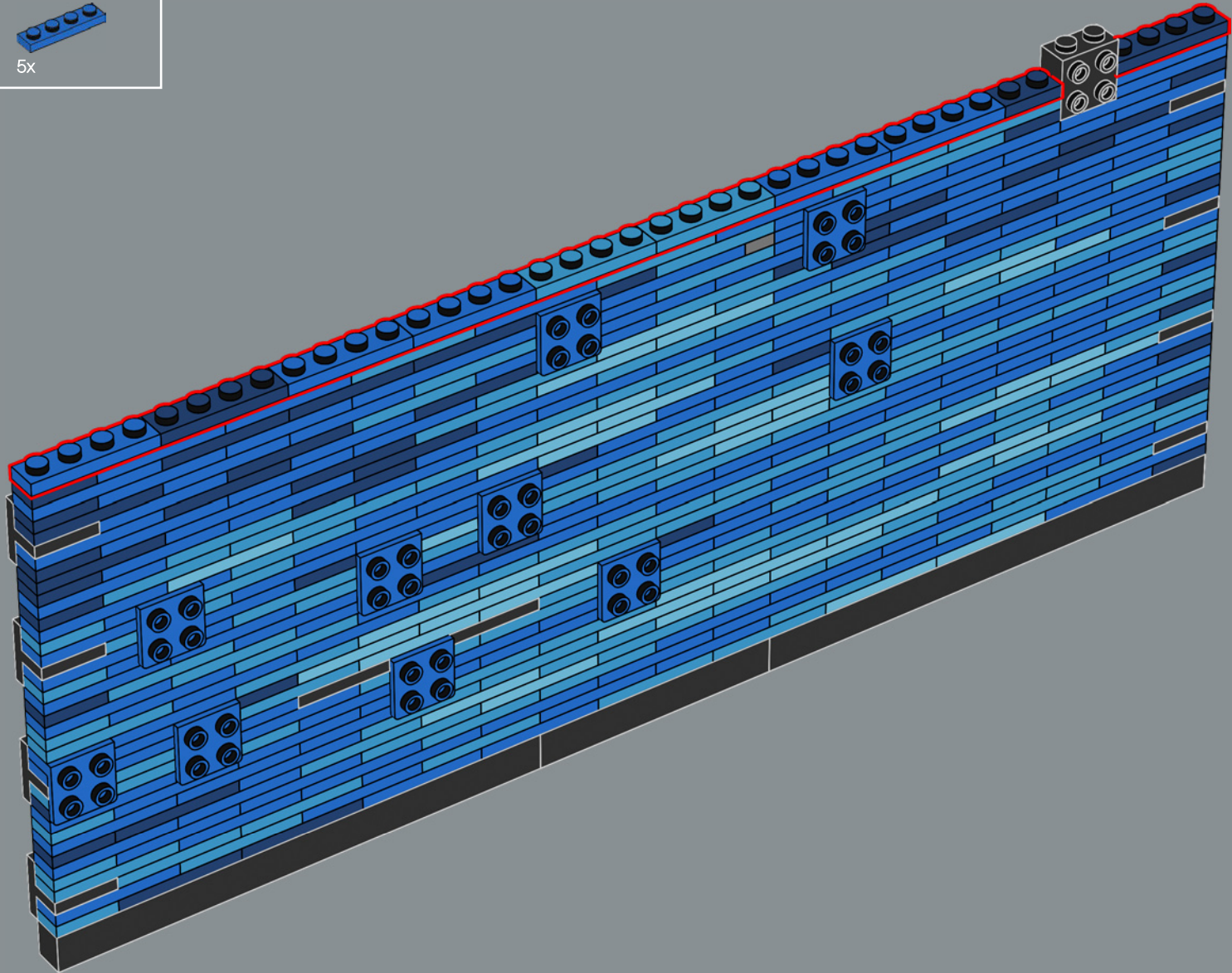

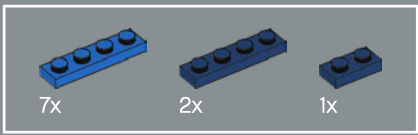

126

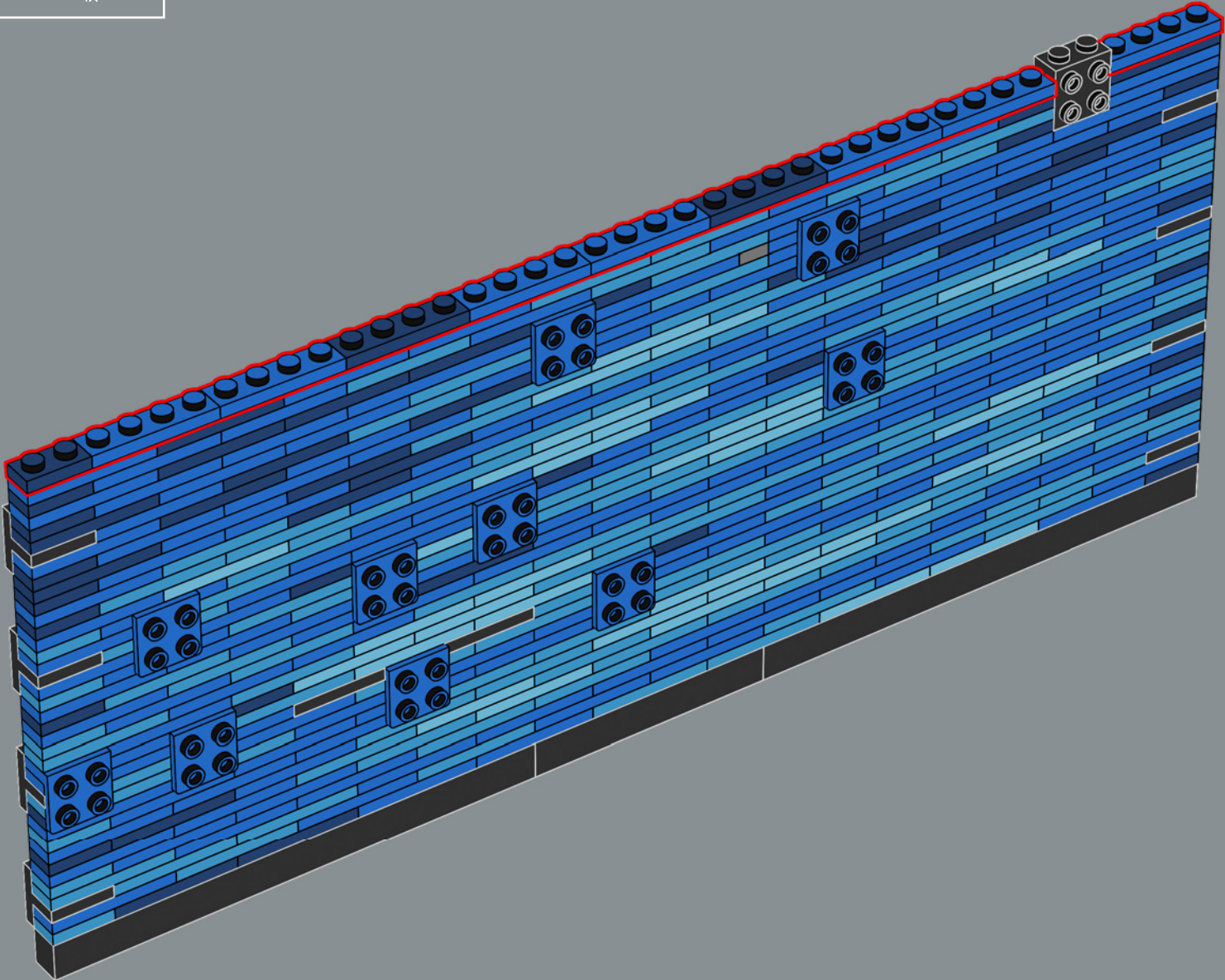

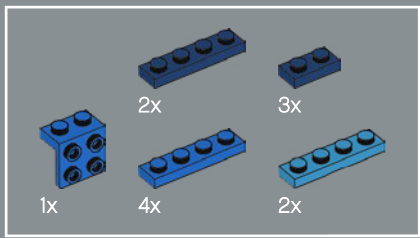

128

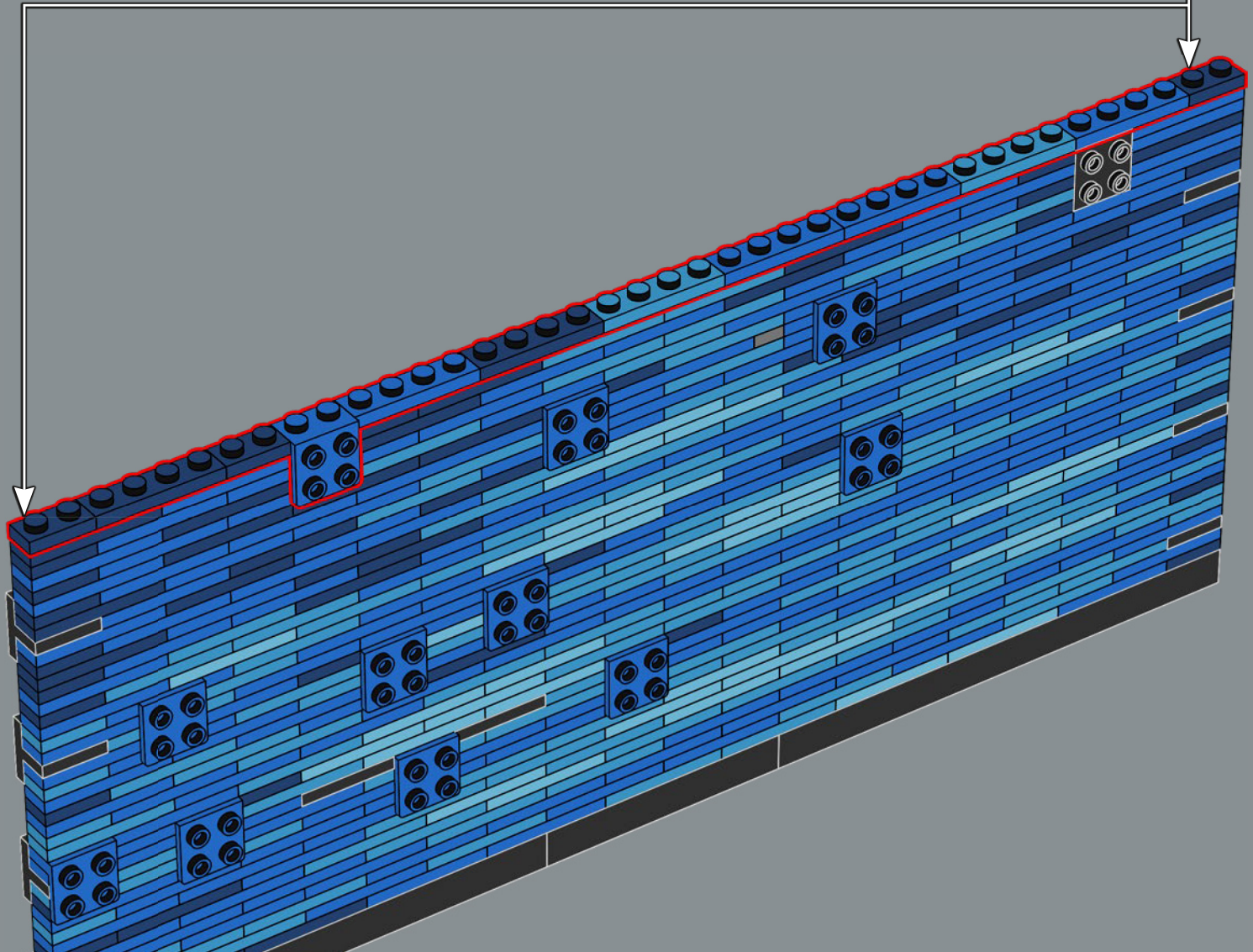
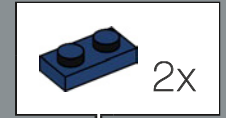

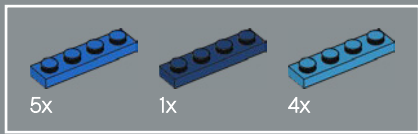

129

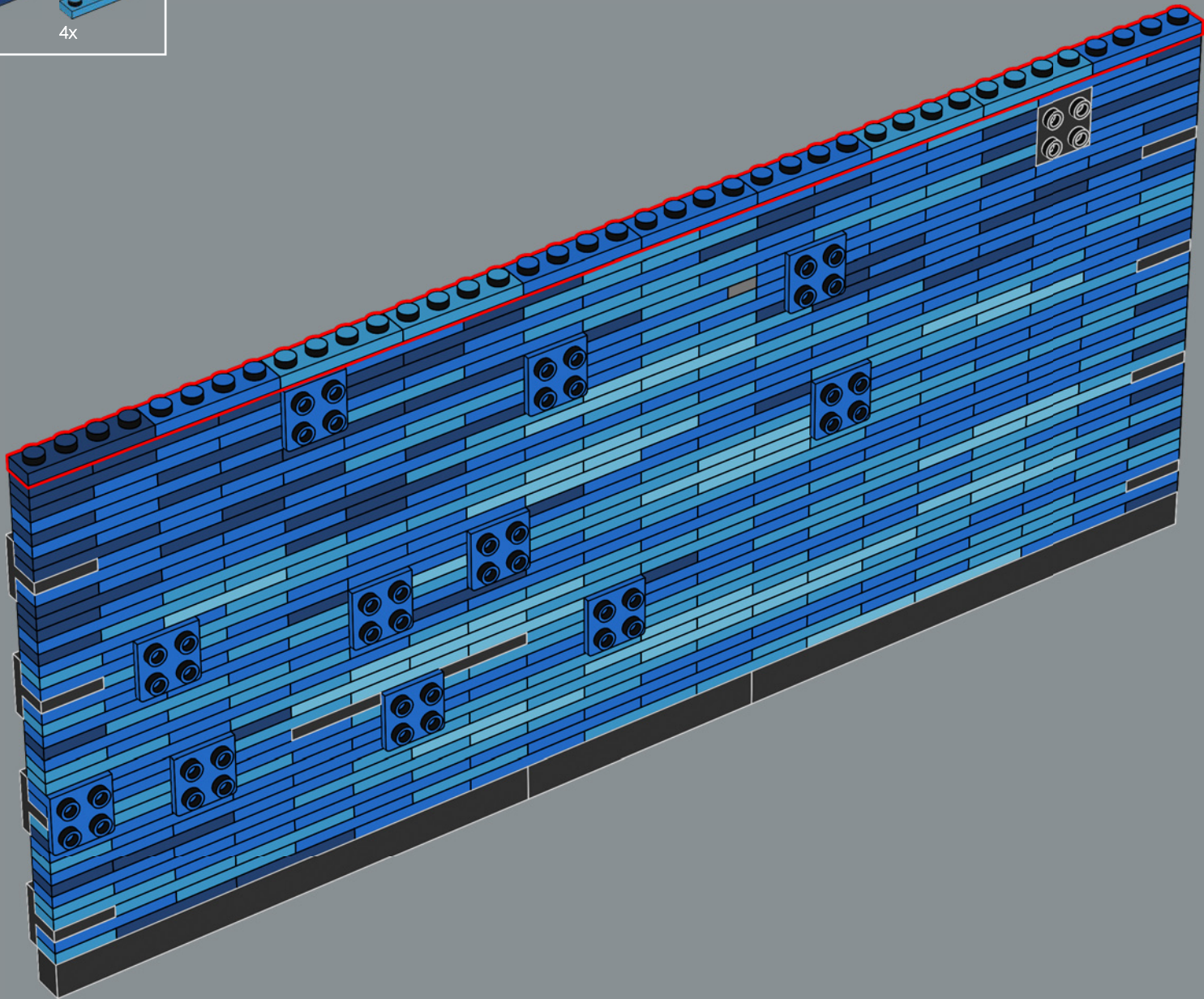

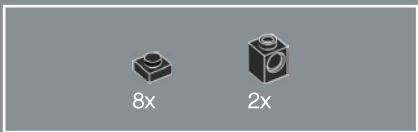

130

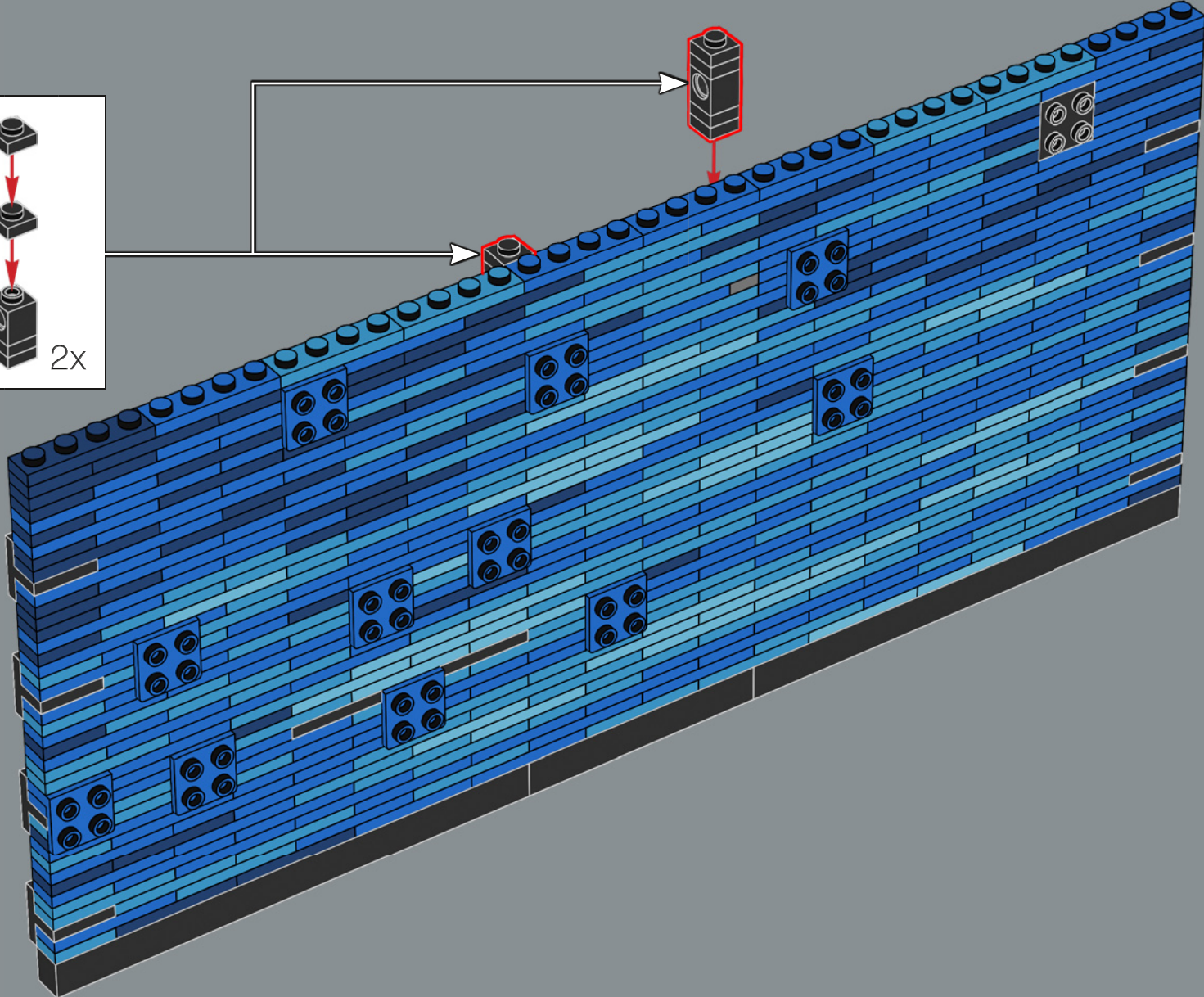
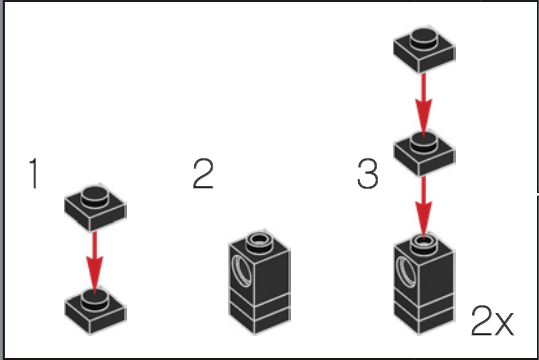

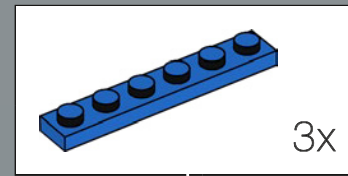
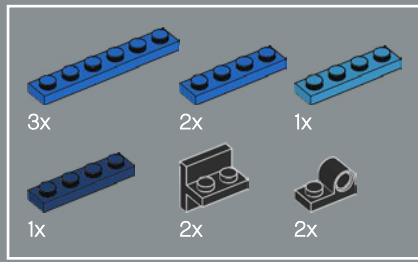

131

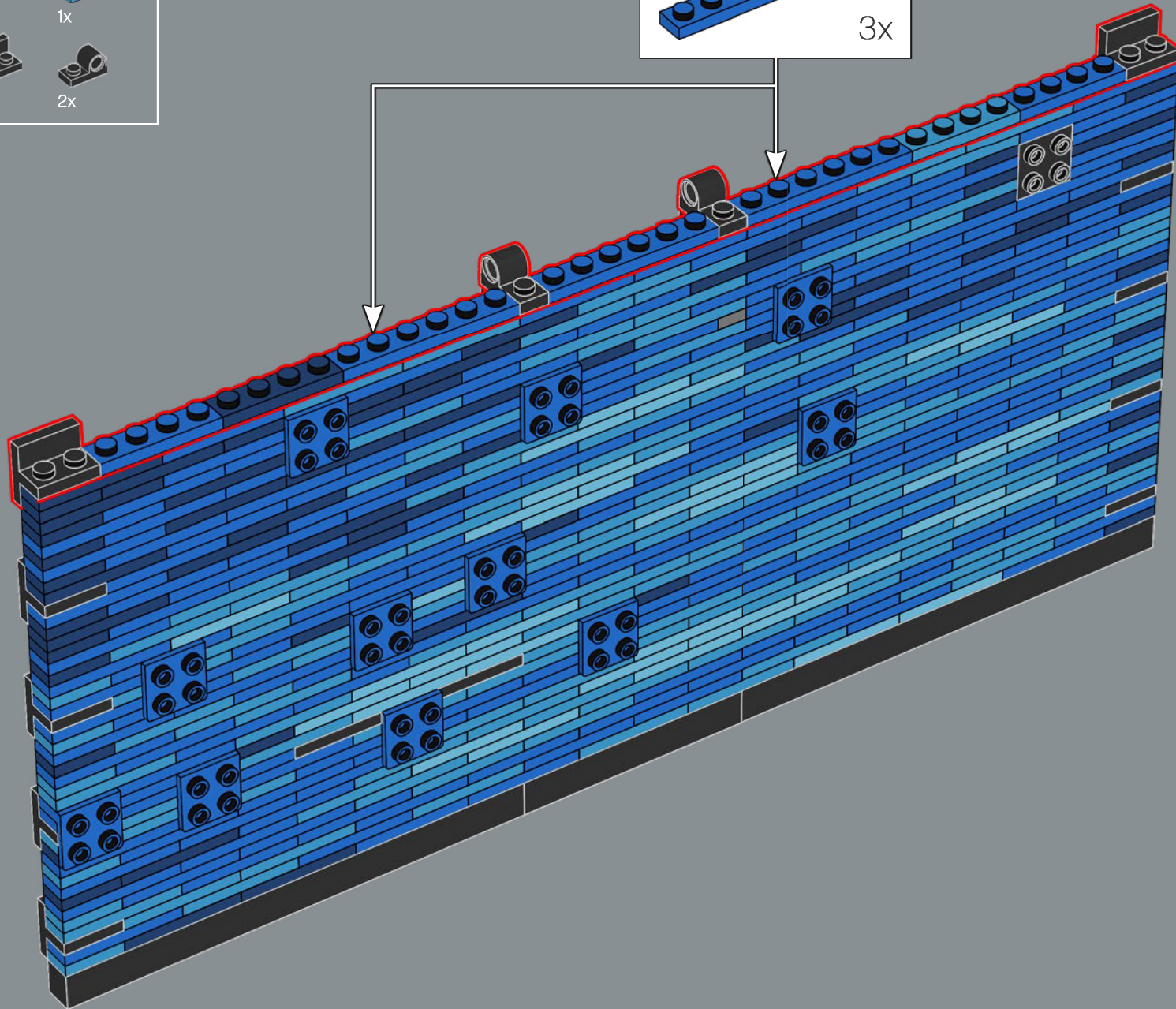

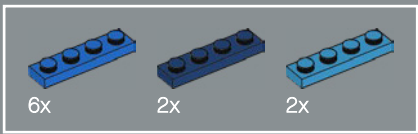

132

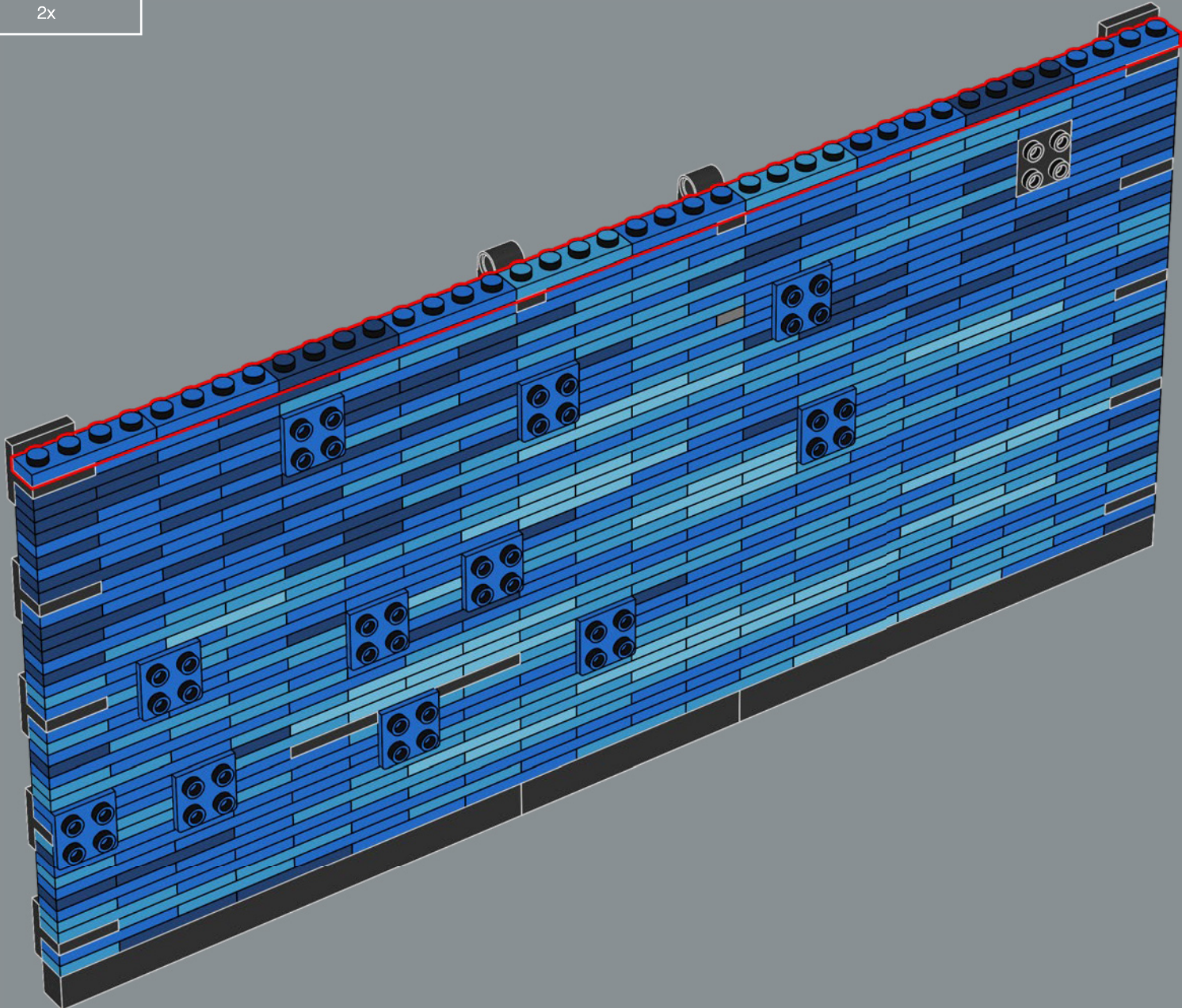

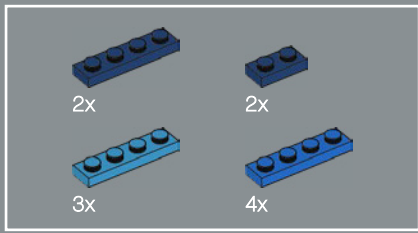

133

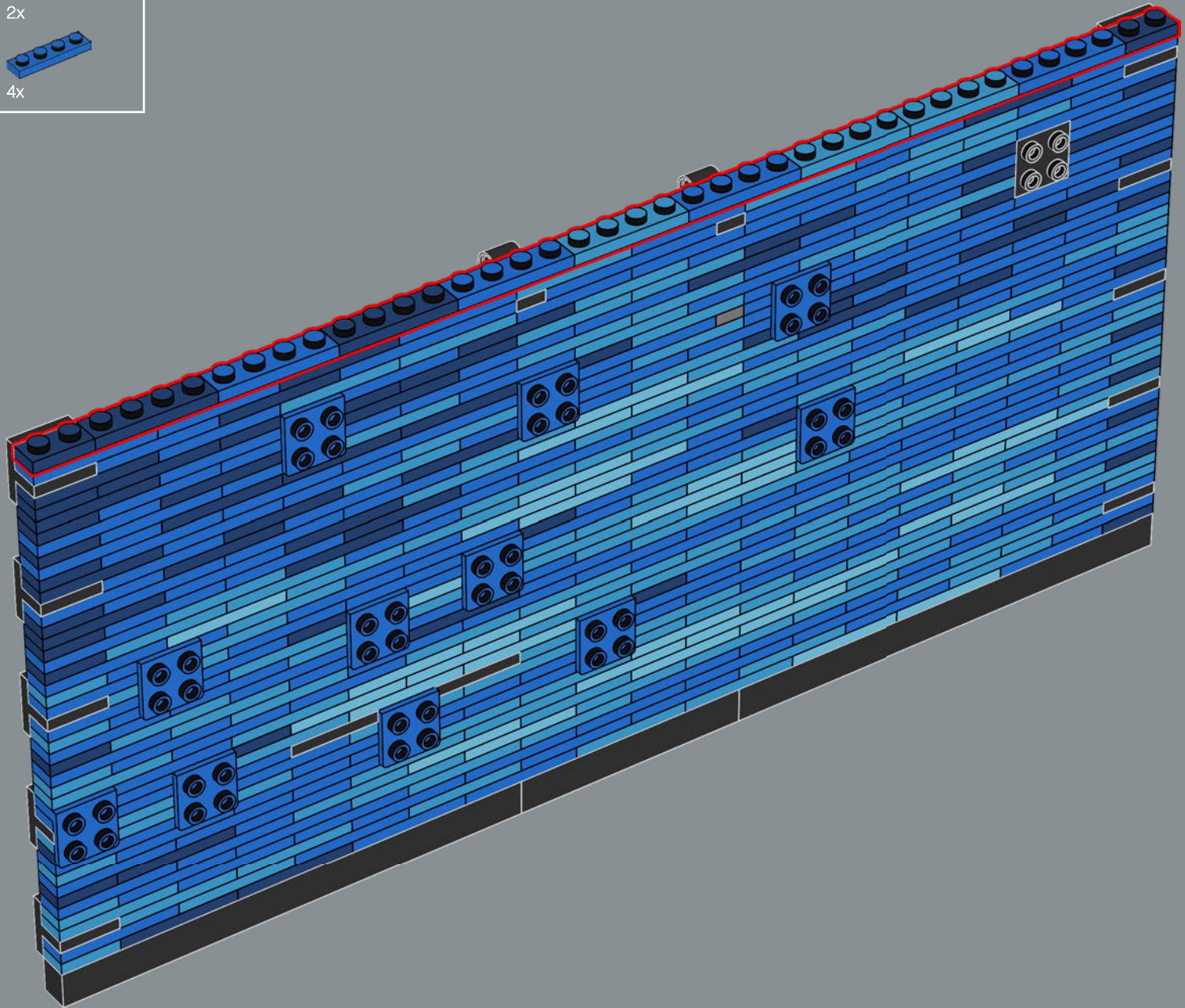

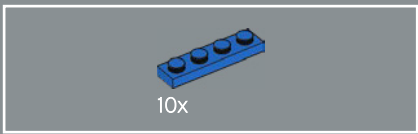

134

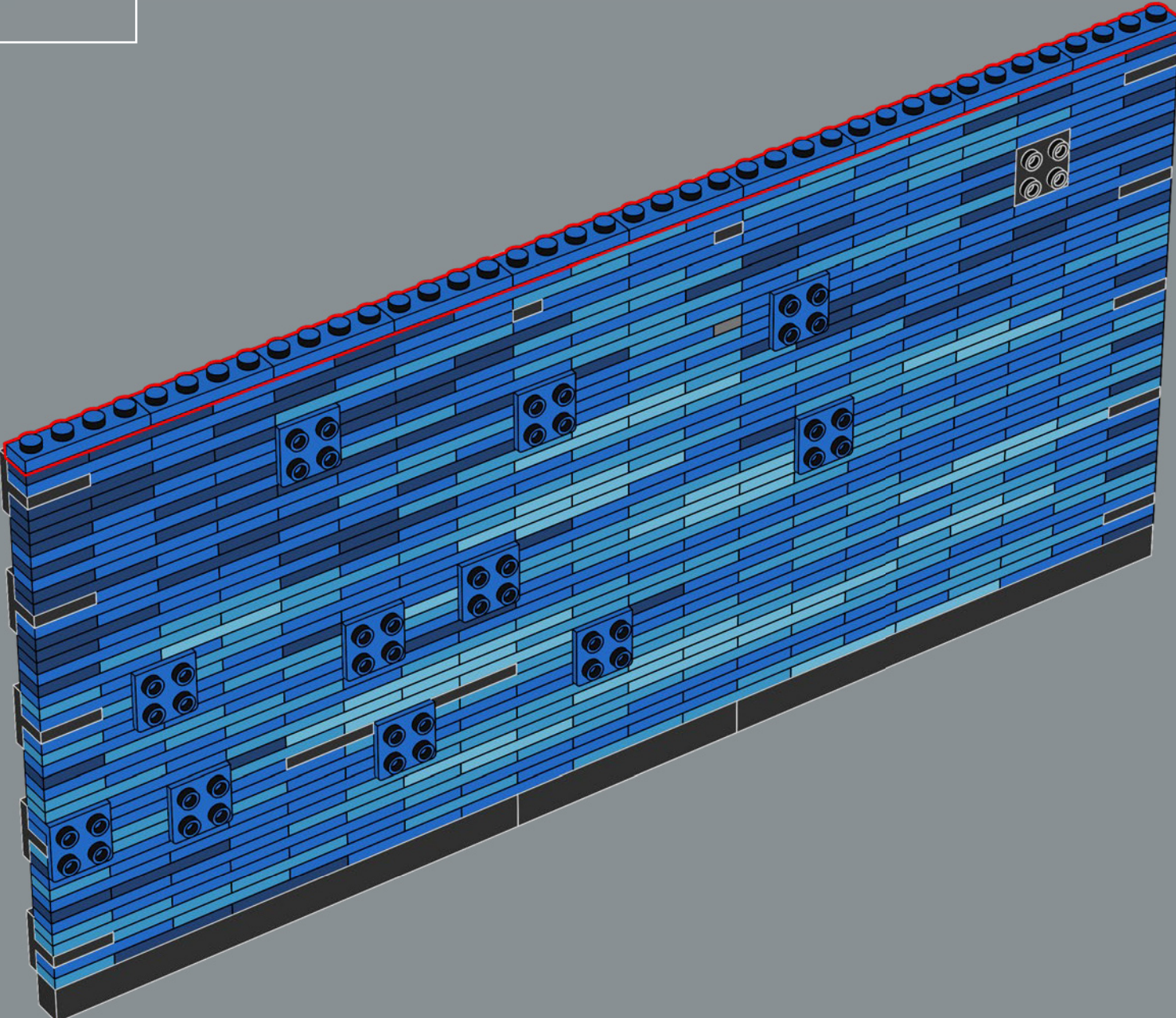

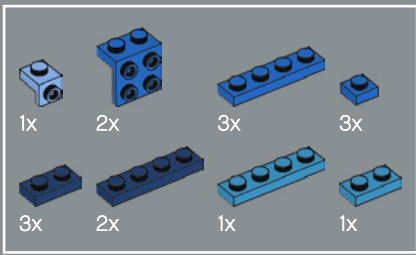

135

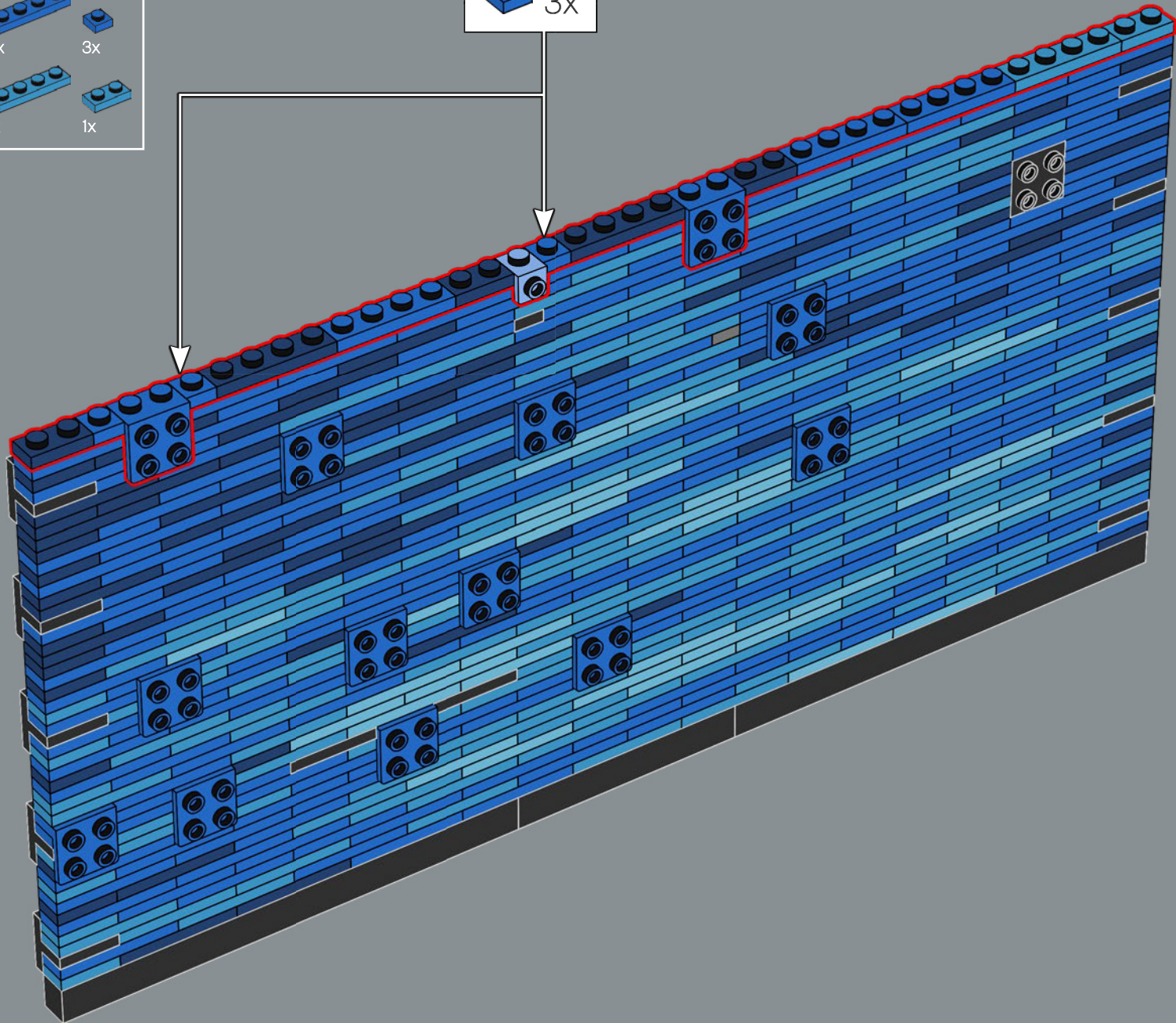

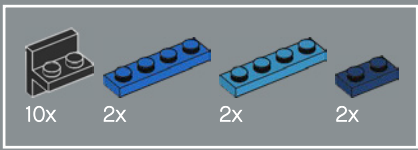

136

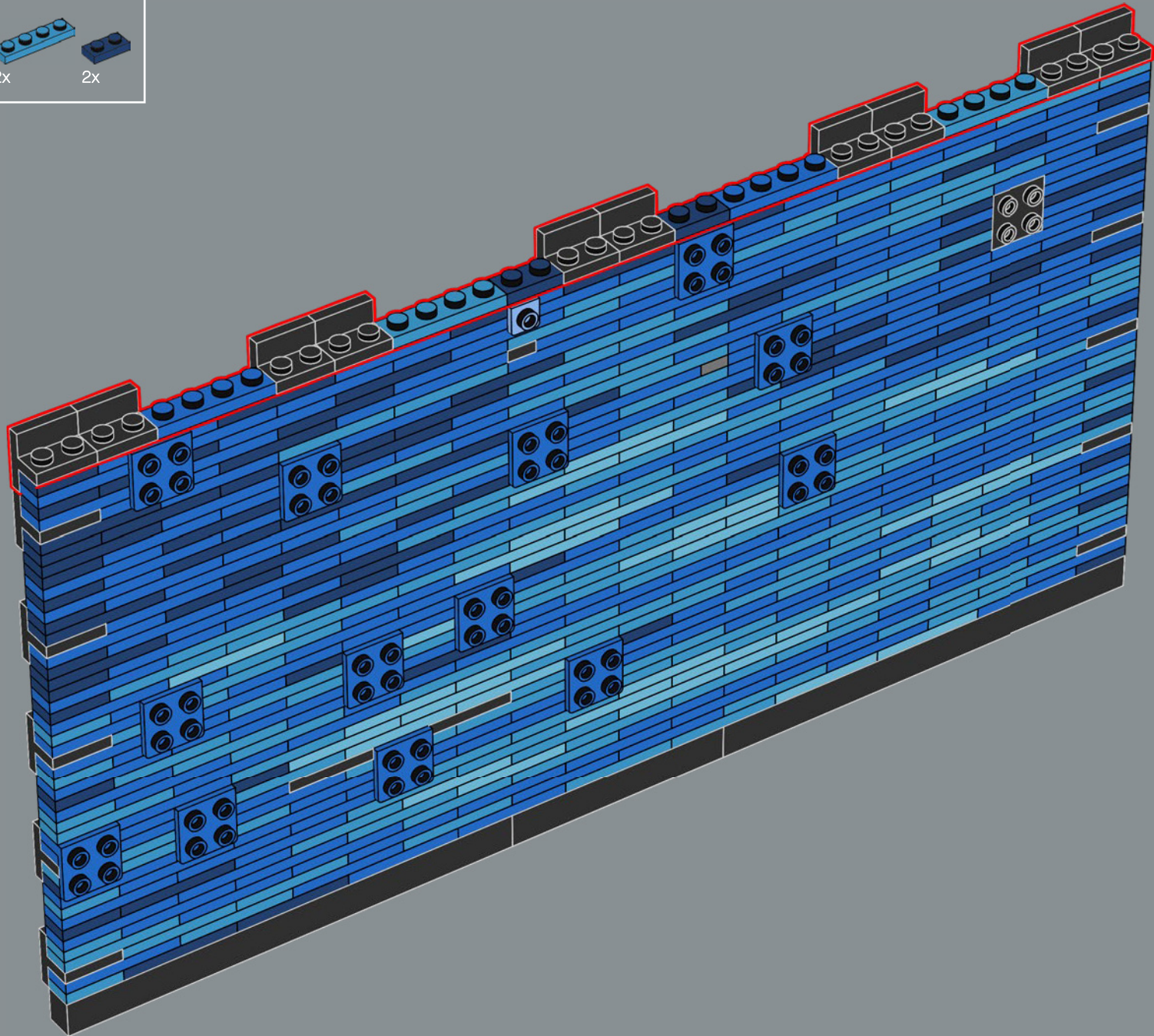

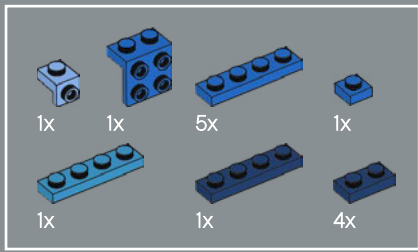

137

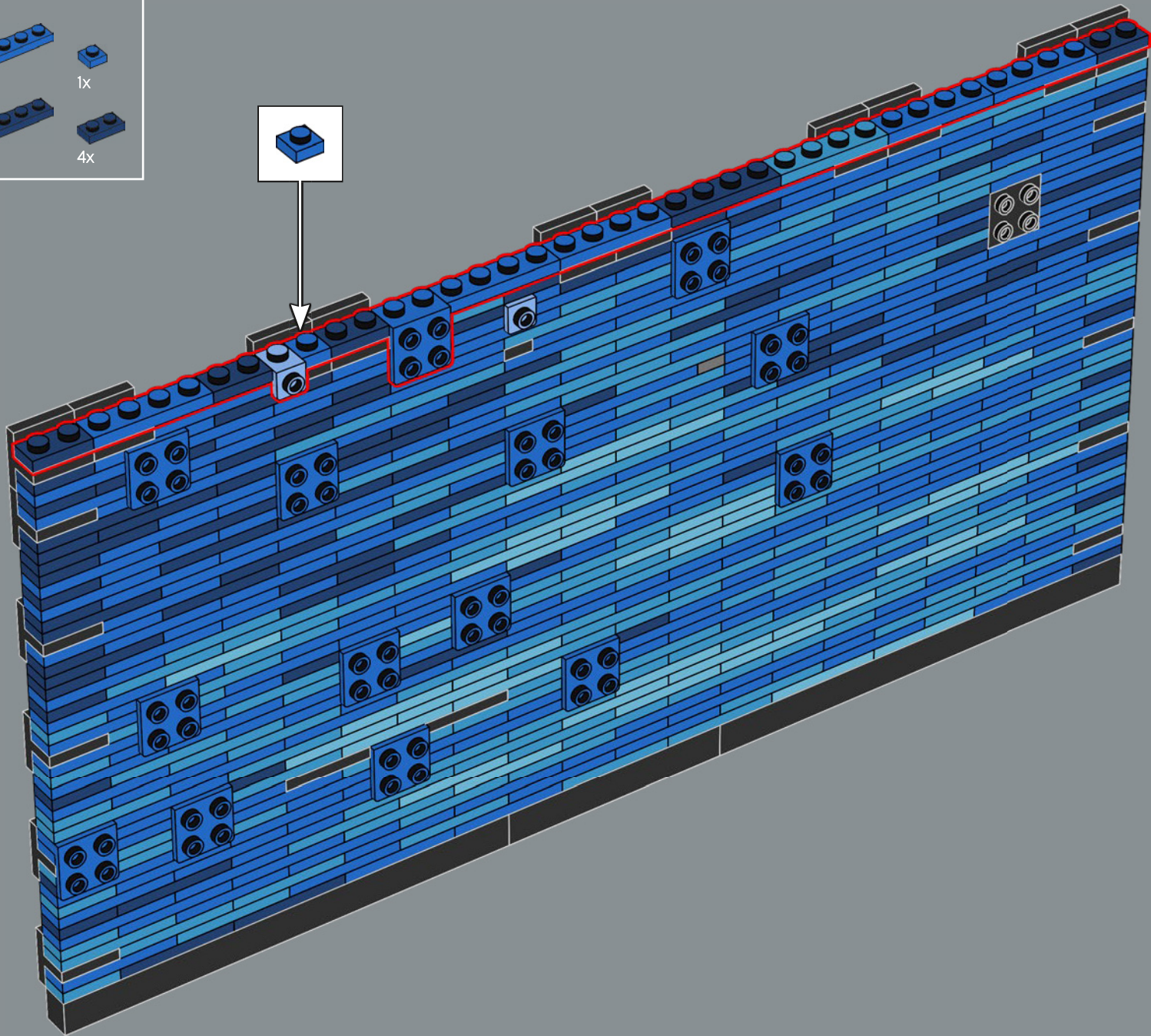

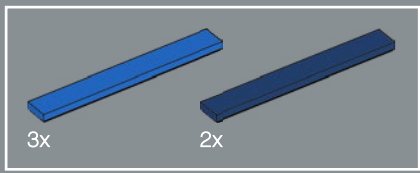

138

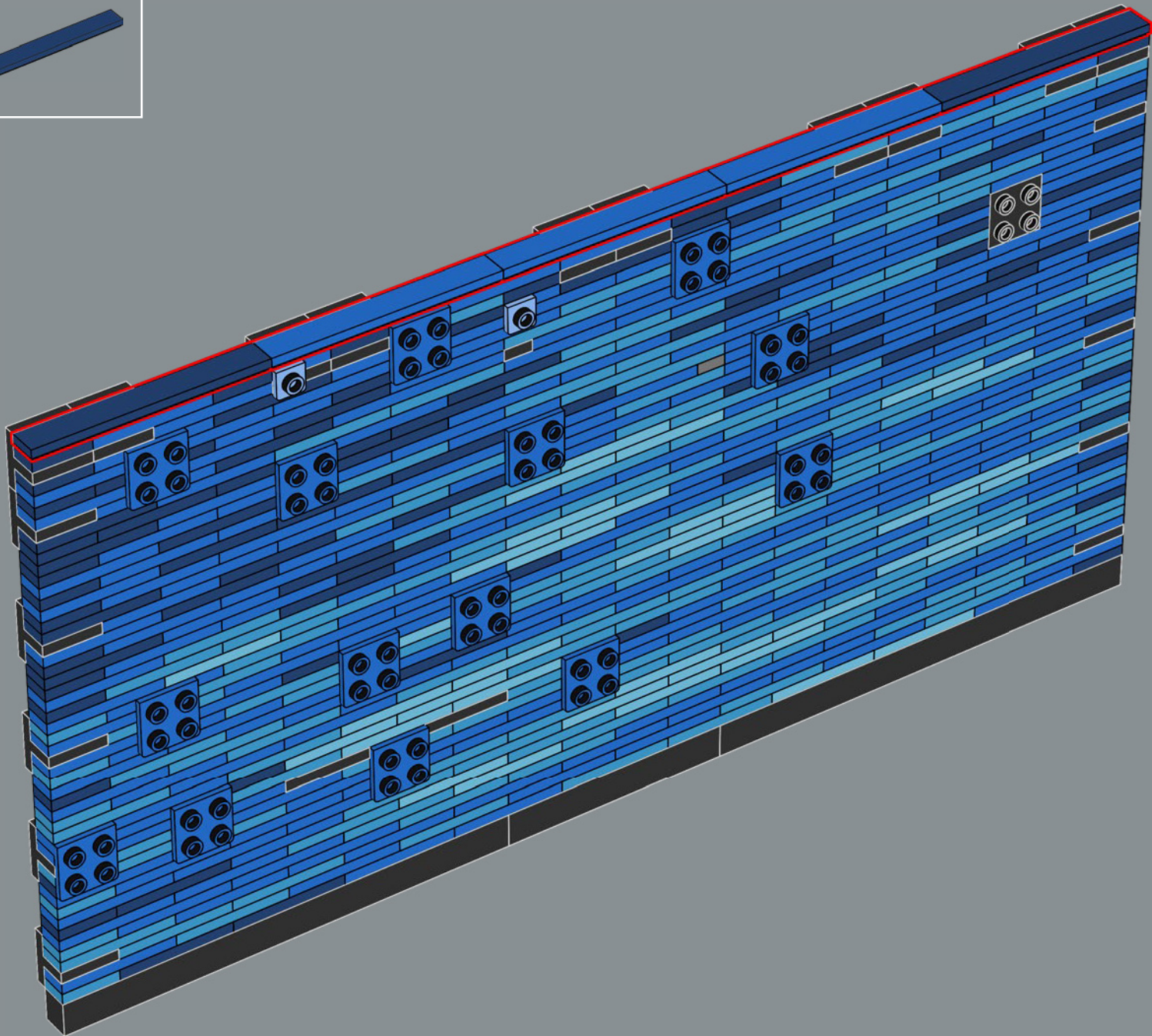

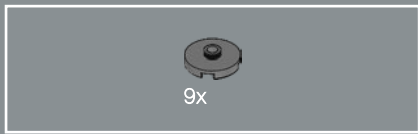

139

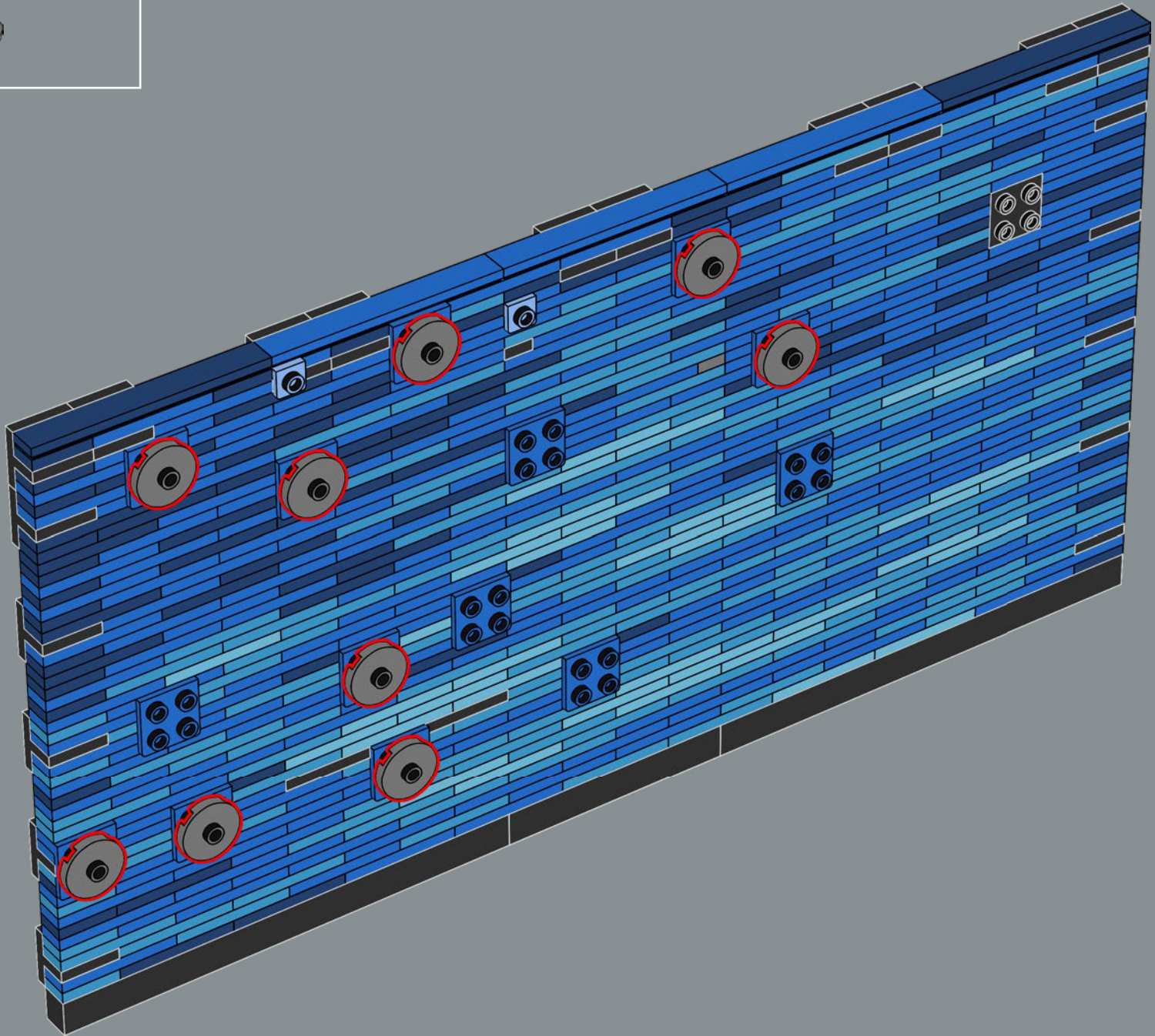



140

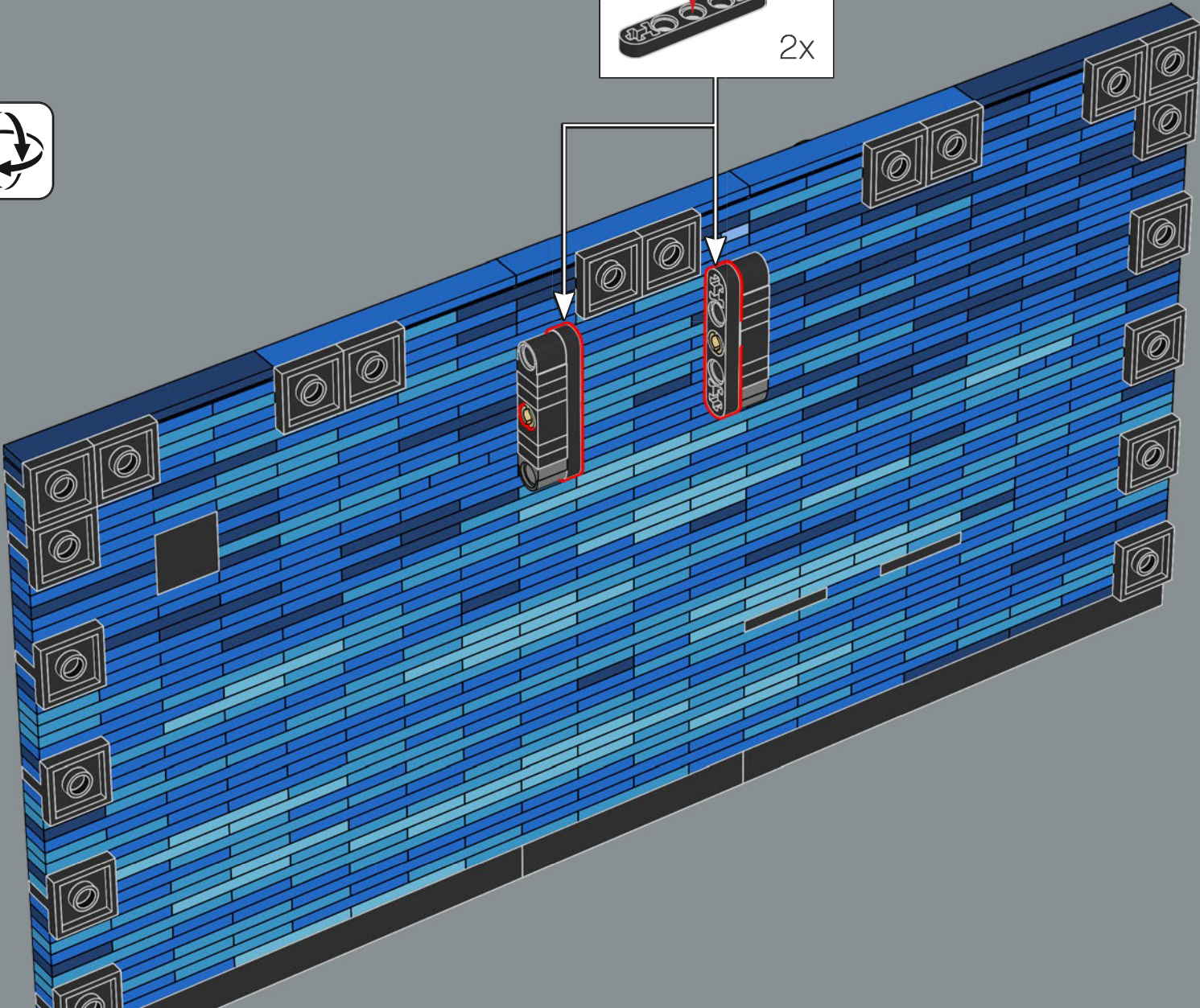
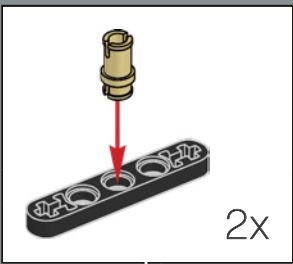

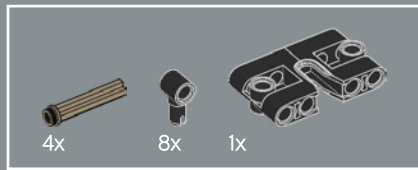

141

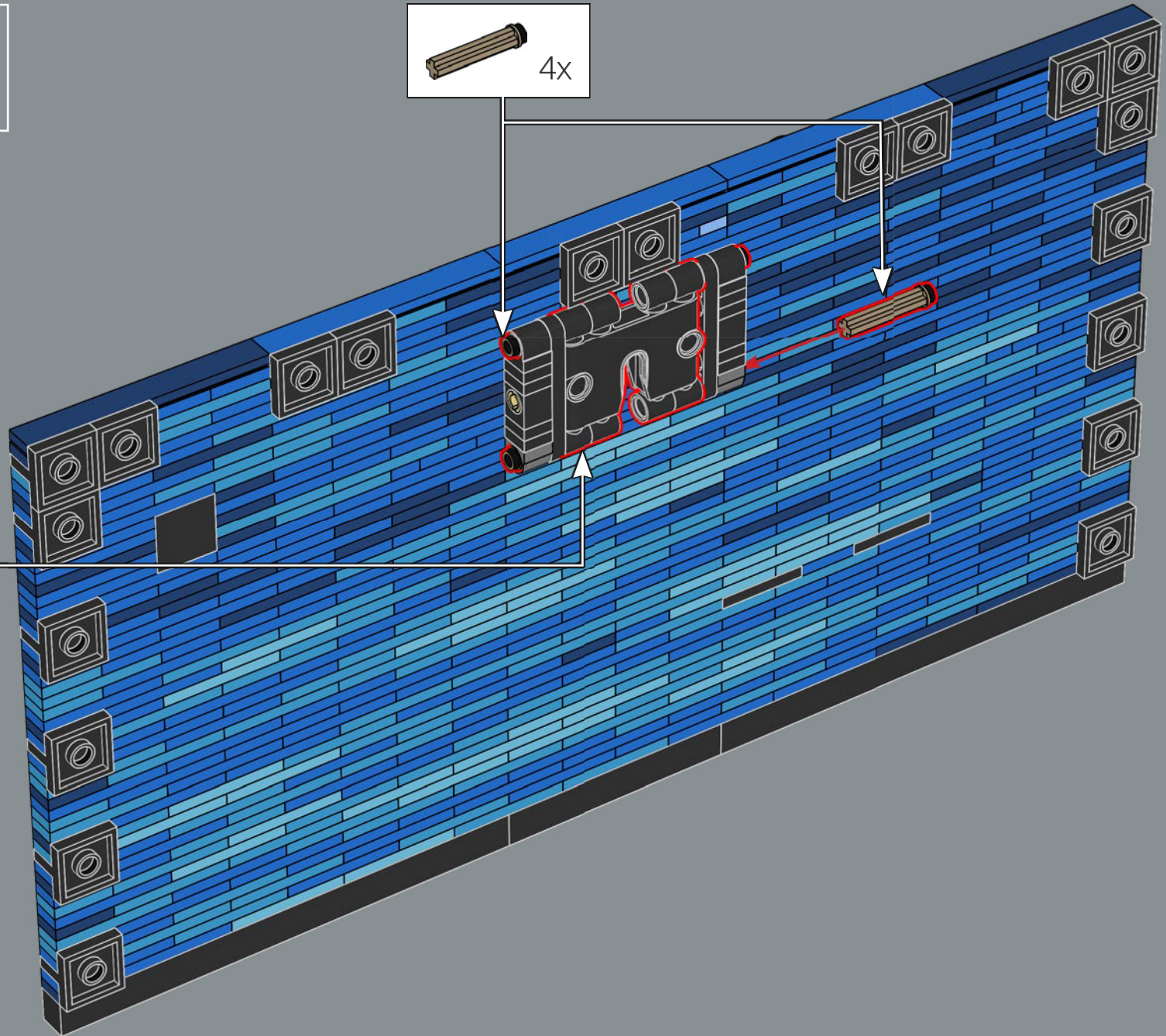
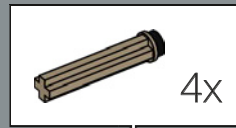
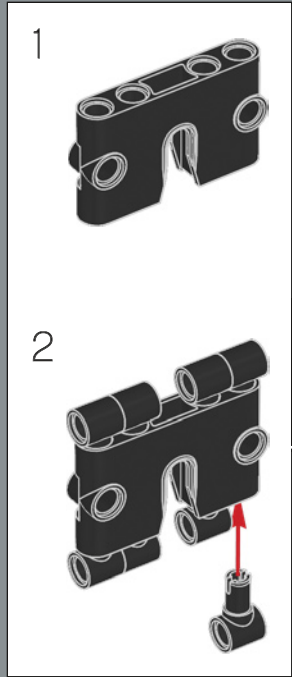

142

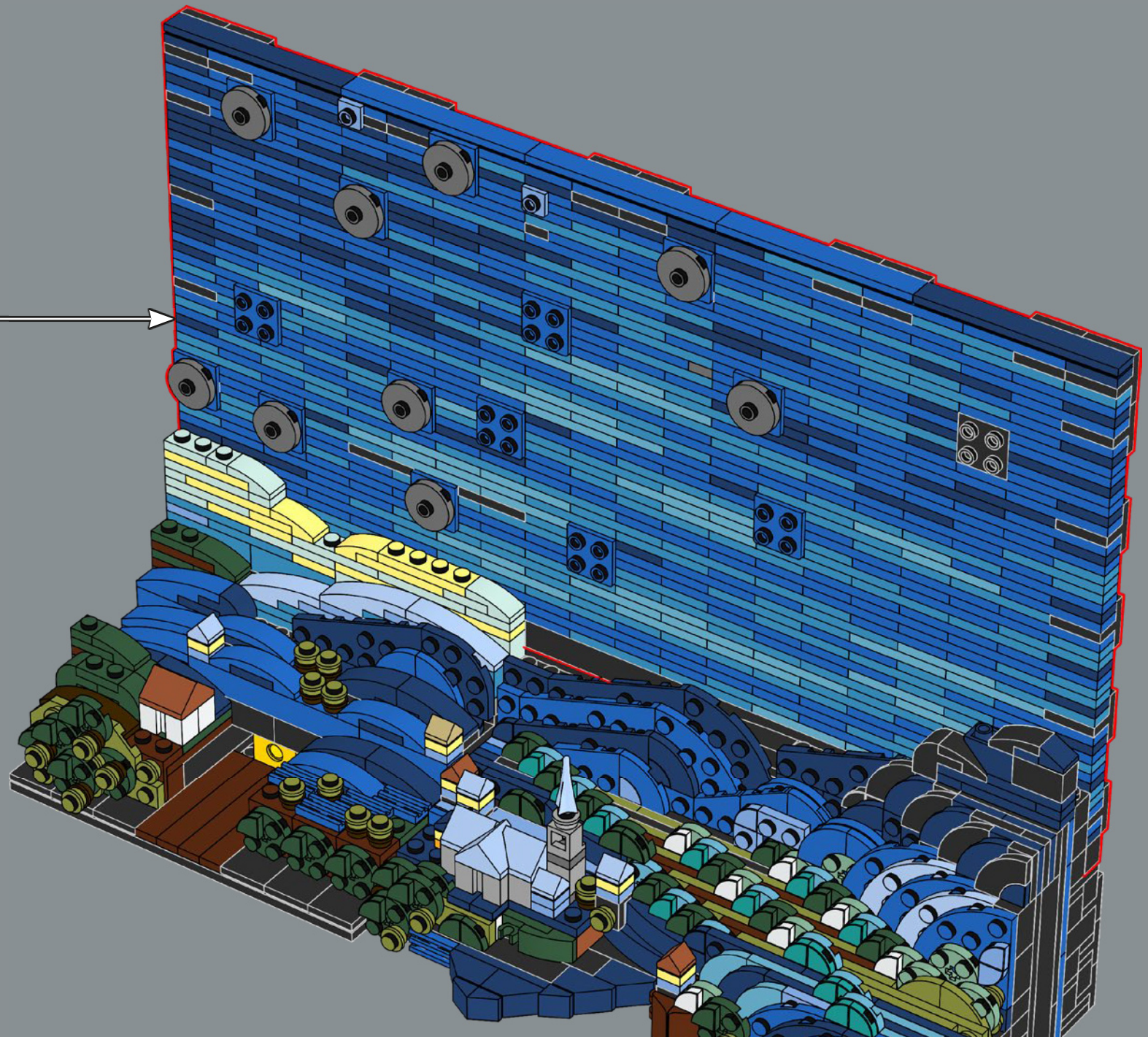

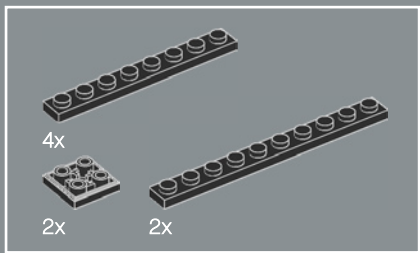

143

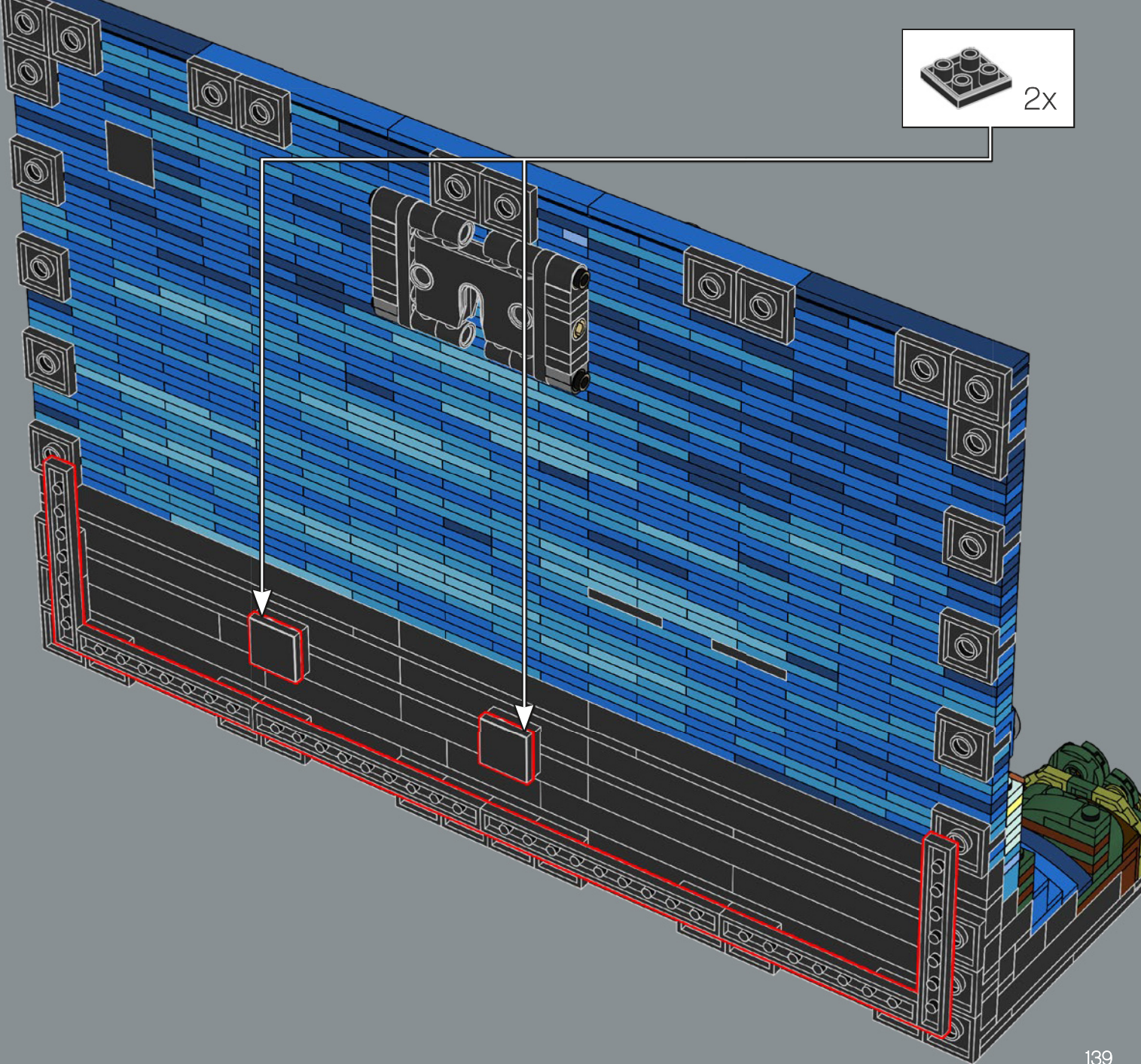

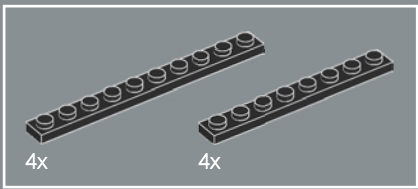

144

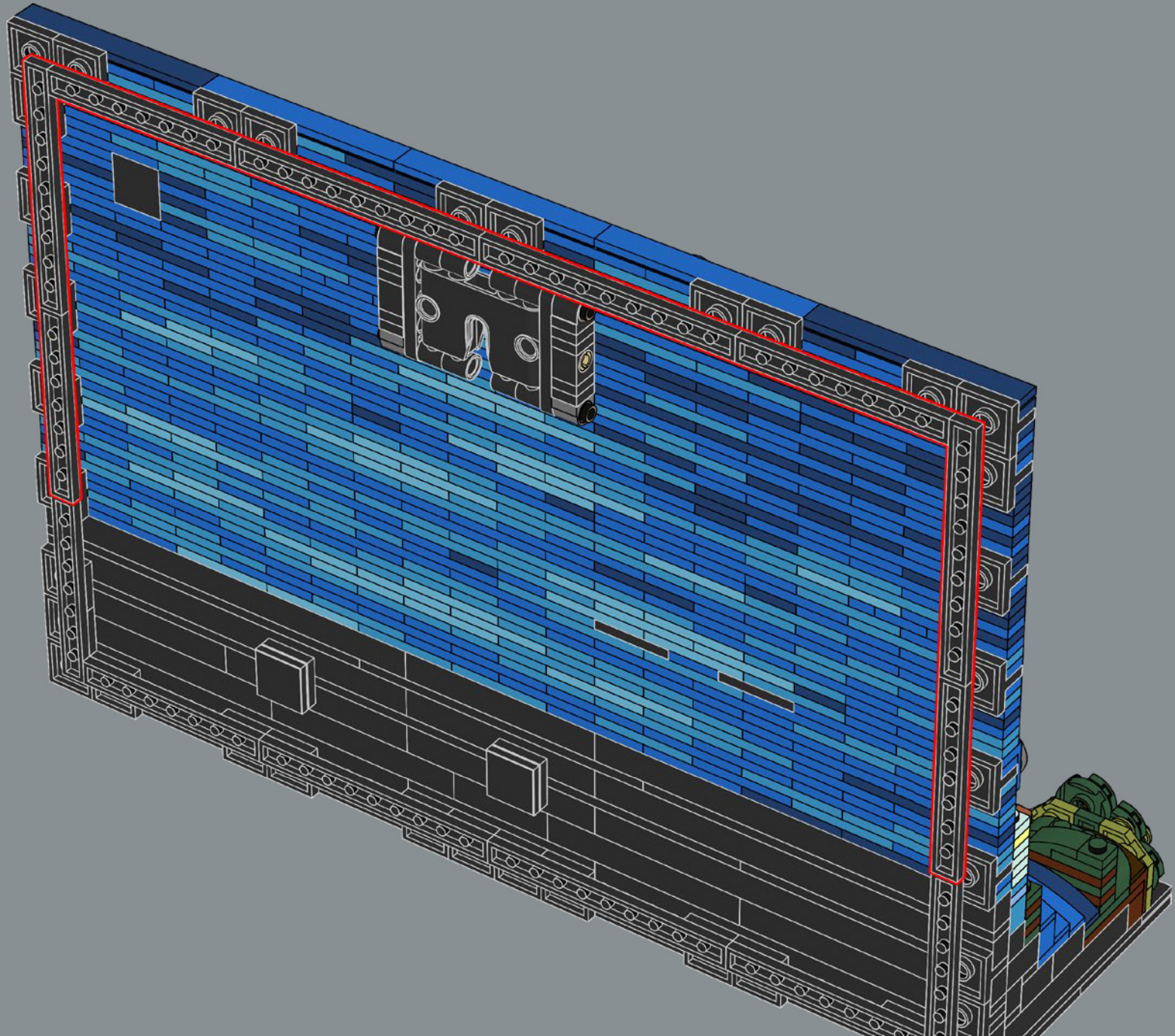

145

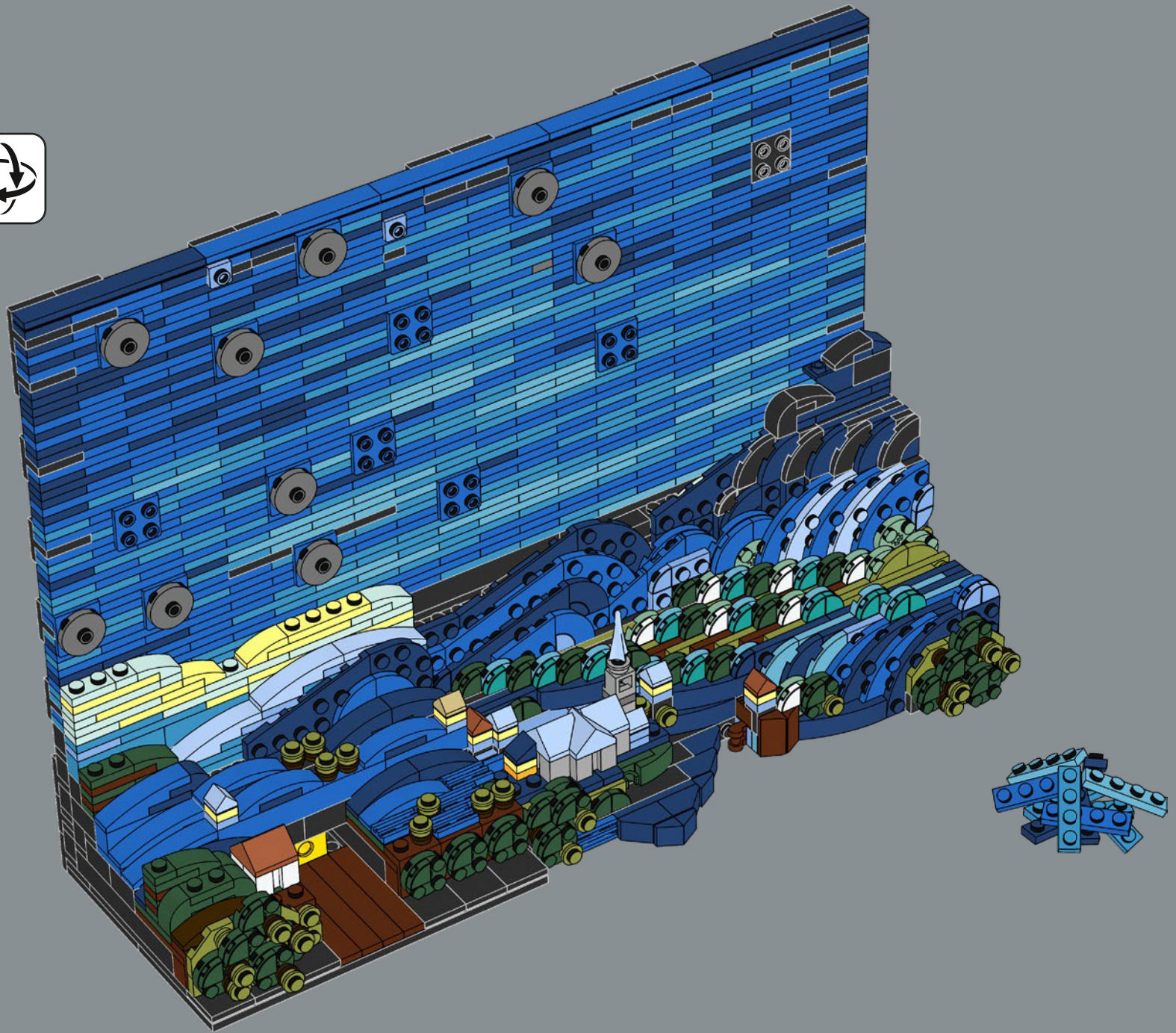



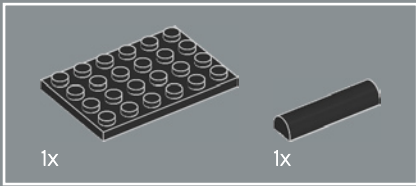
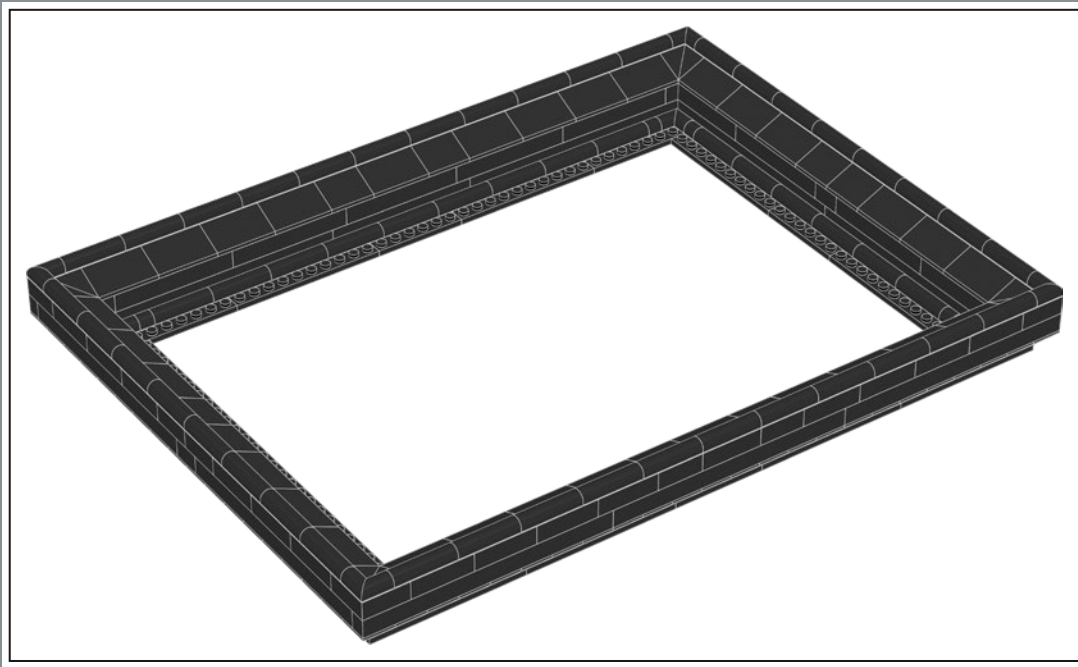

146

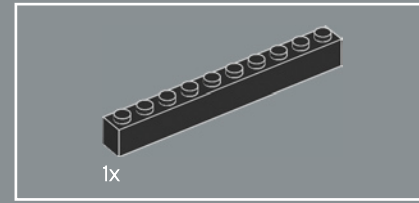
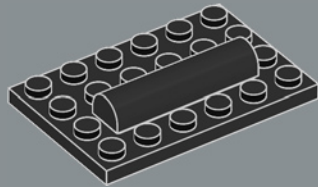

147

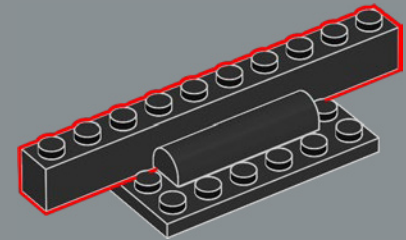

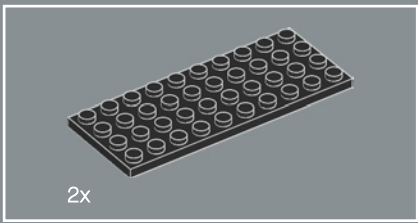

148

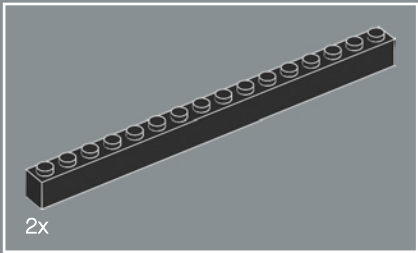
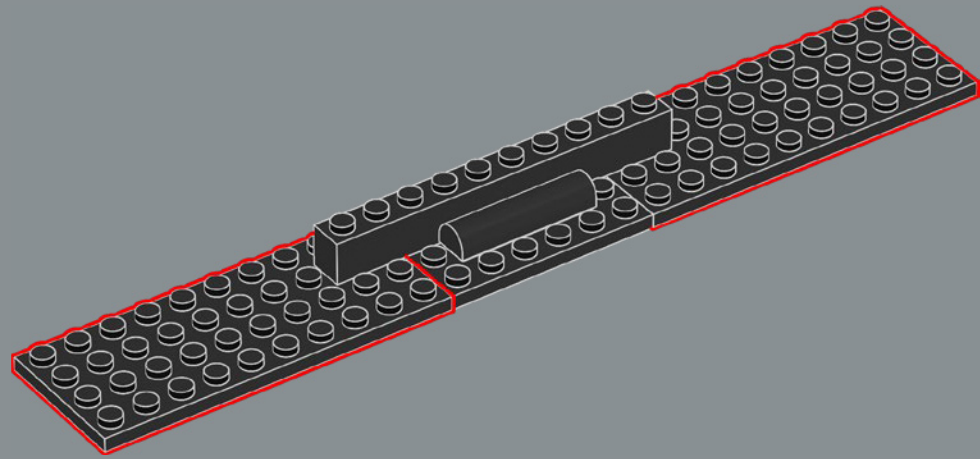

149

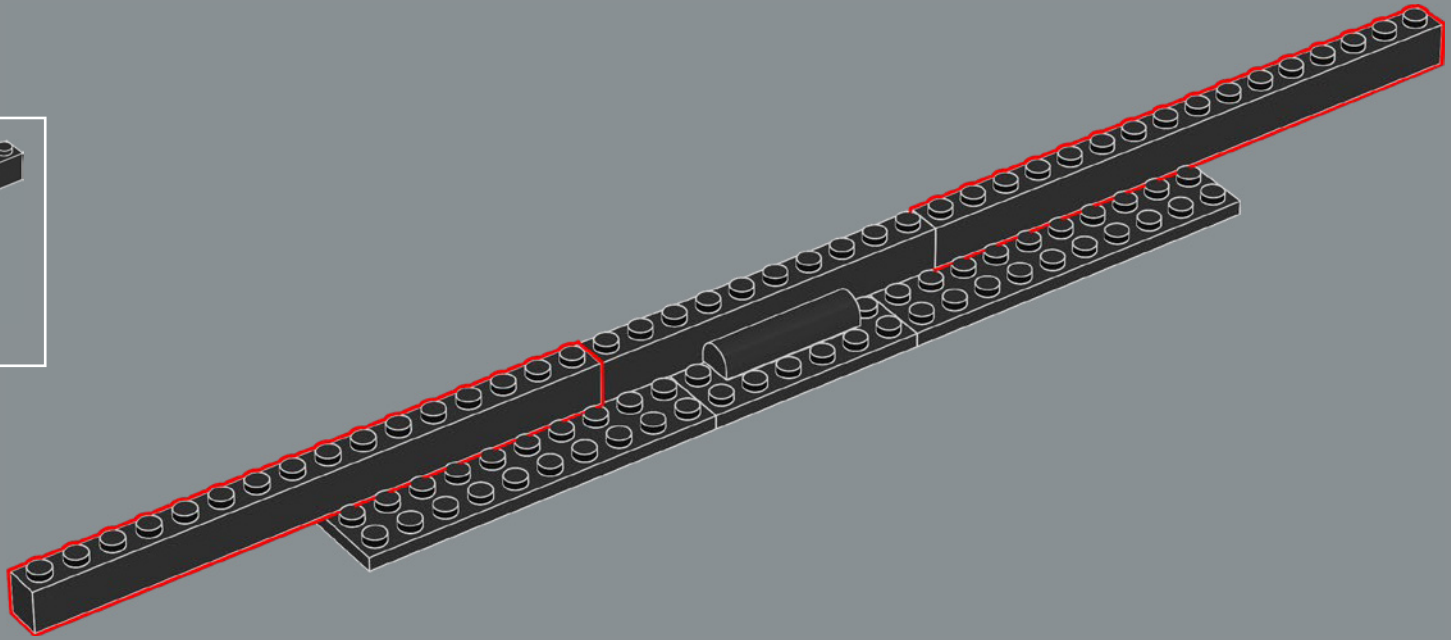

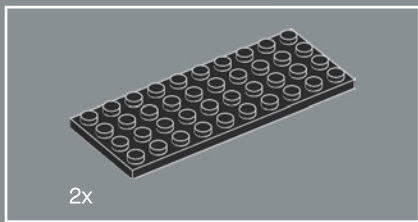

150

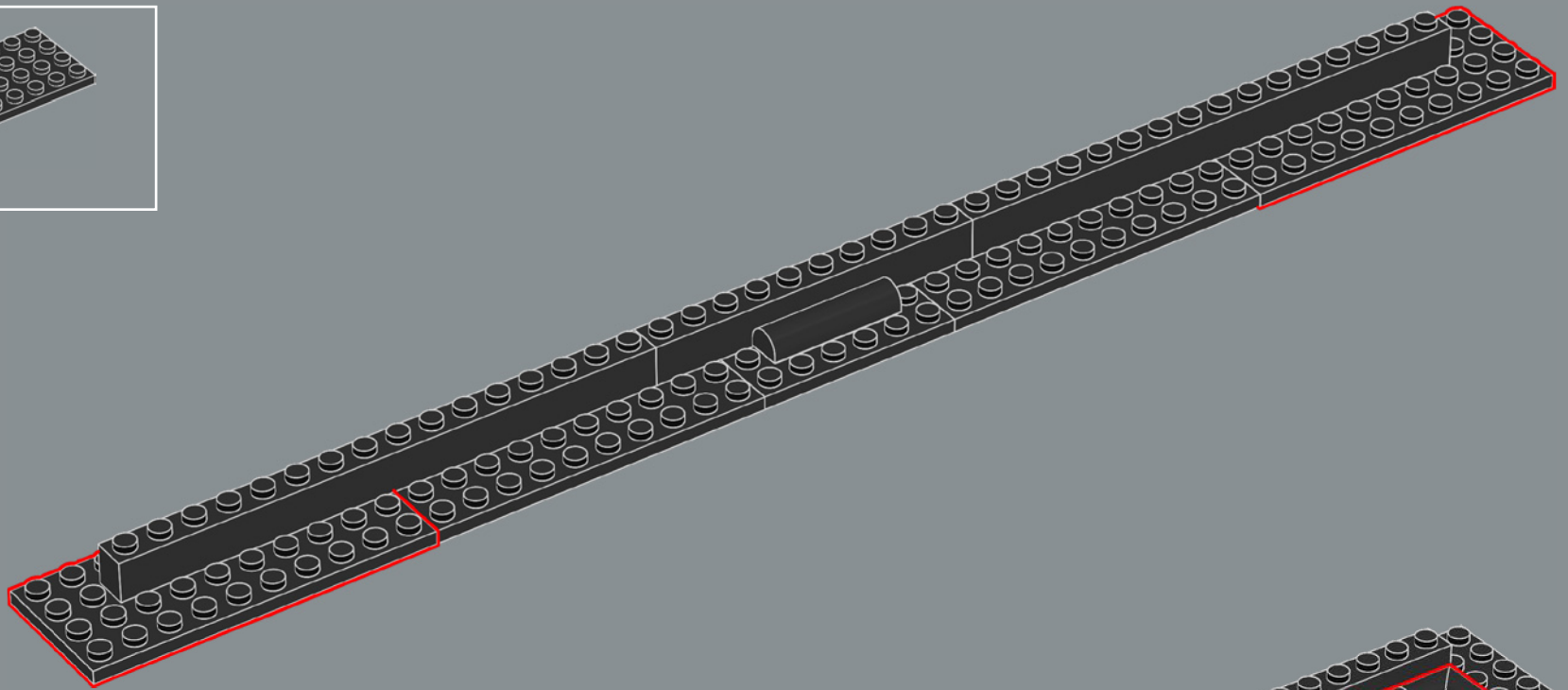

151

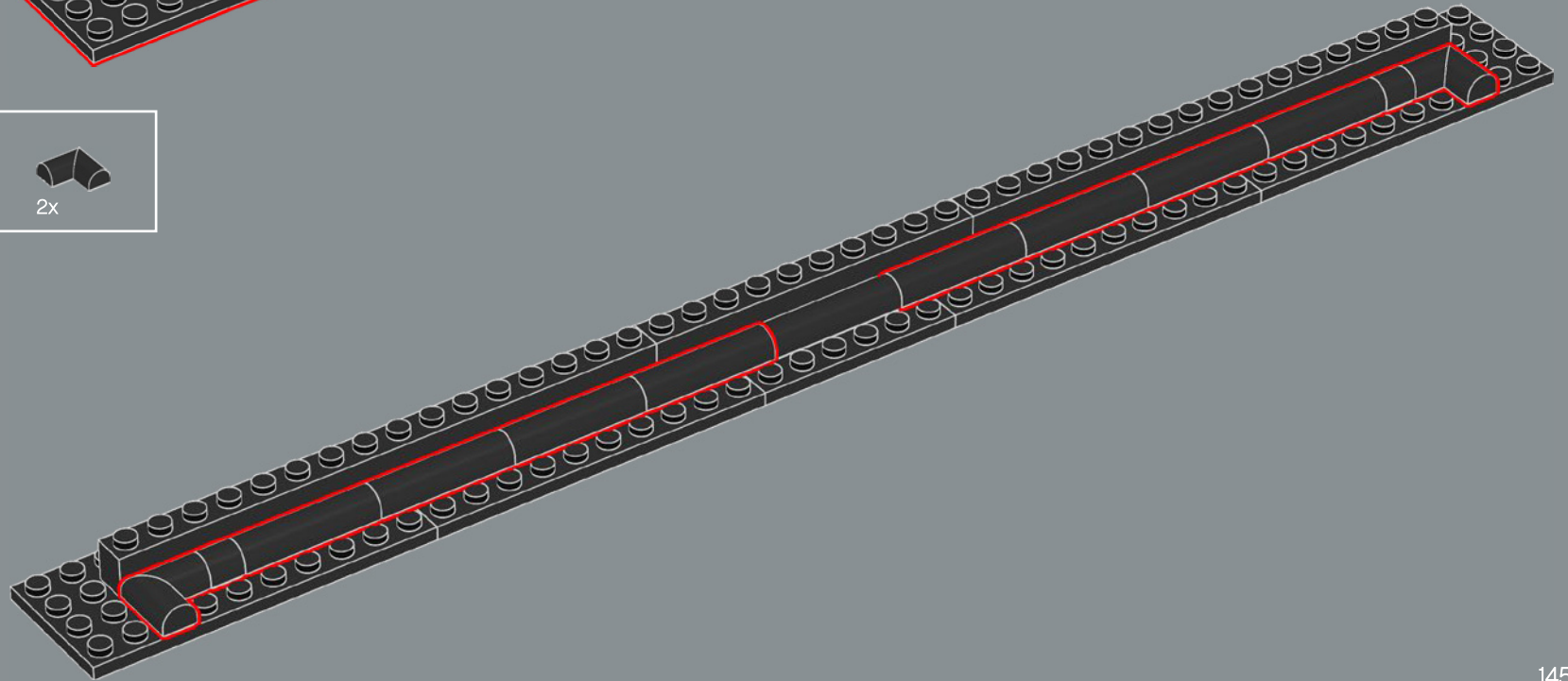

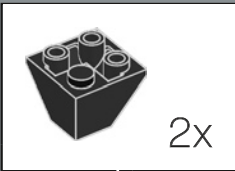
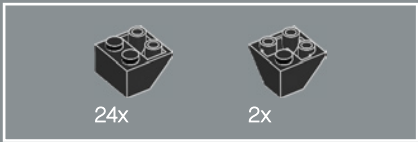

152

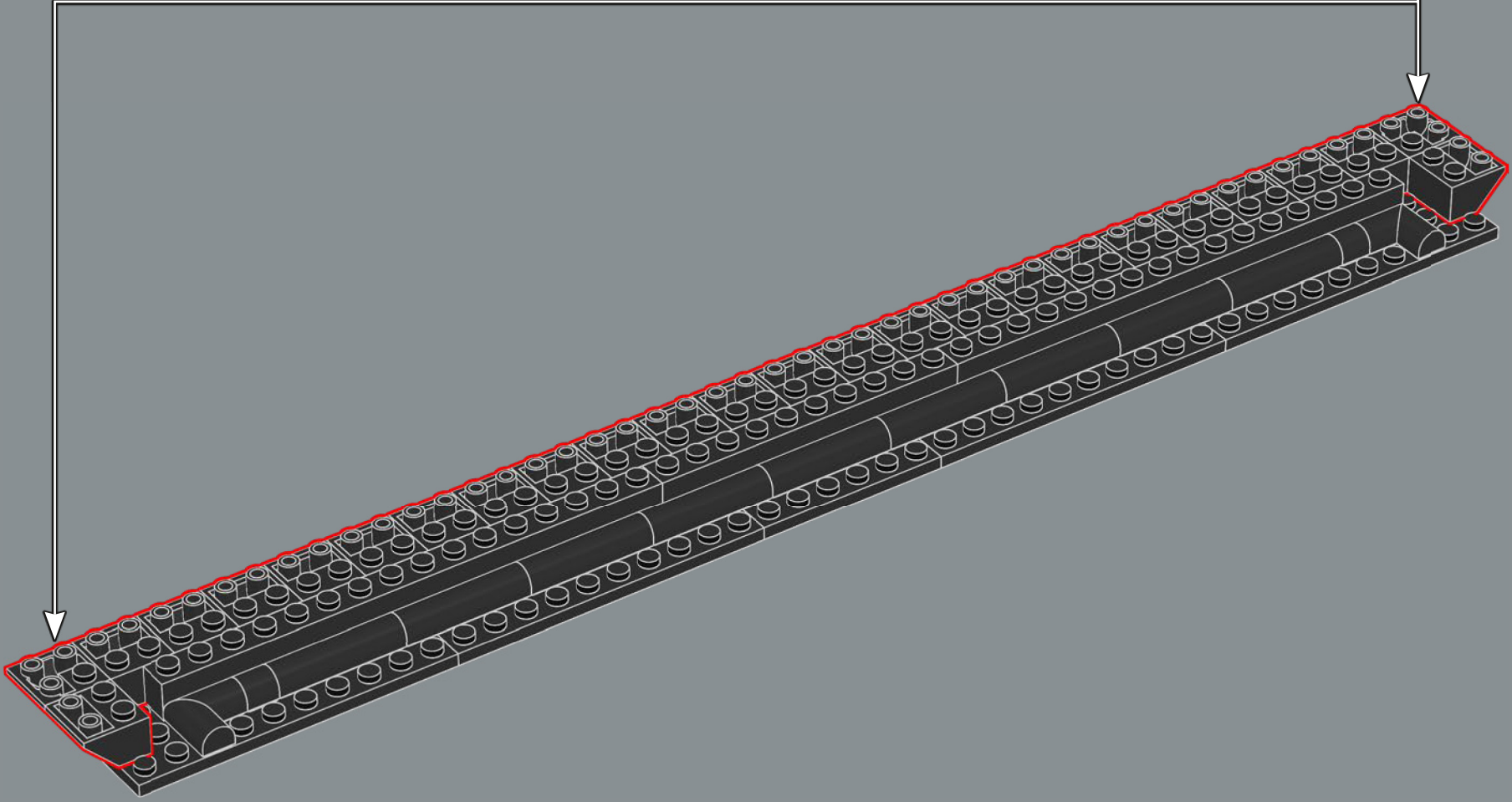

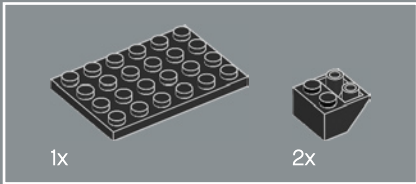
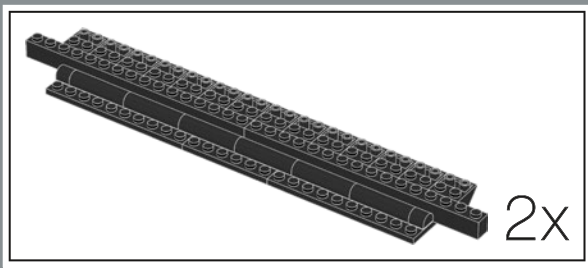

153

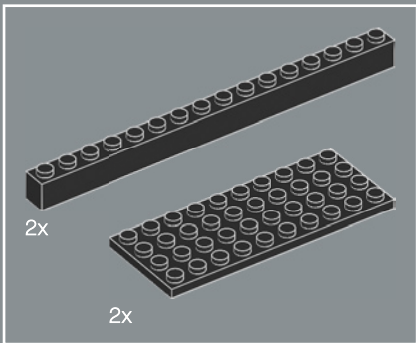
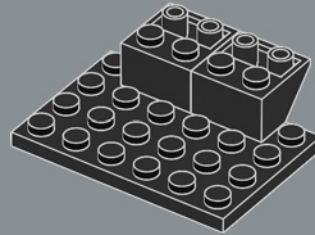

154

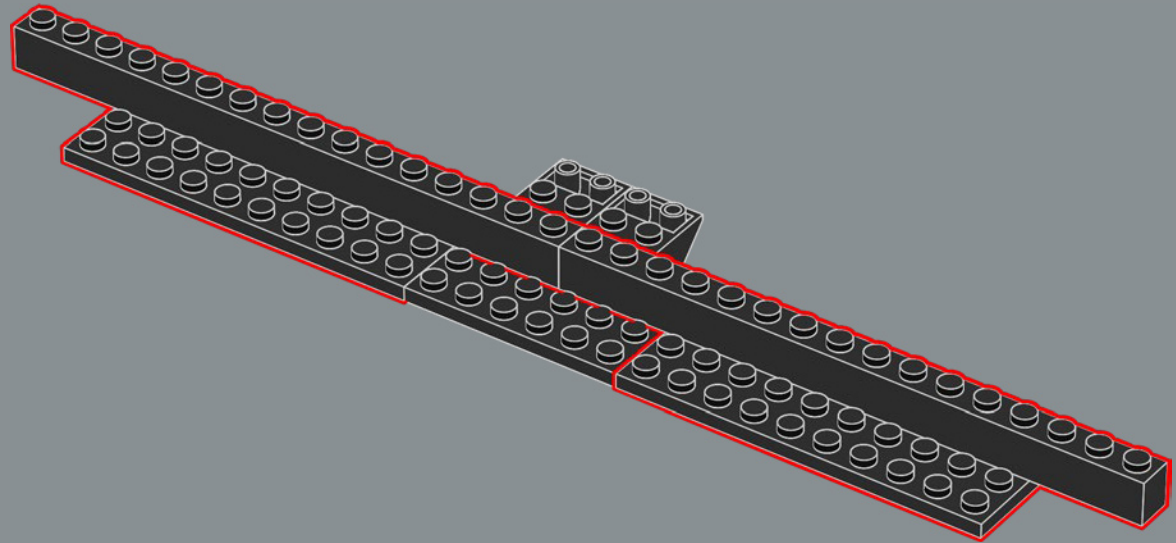

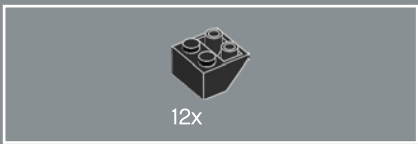

155

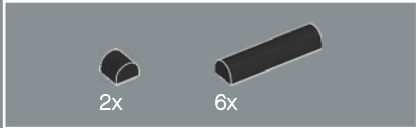
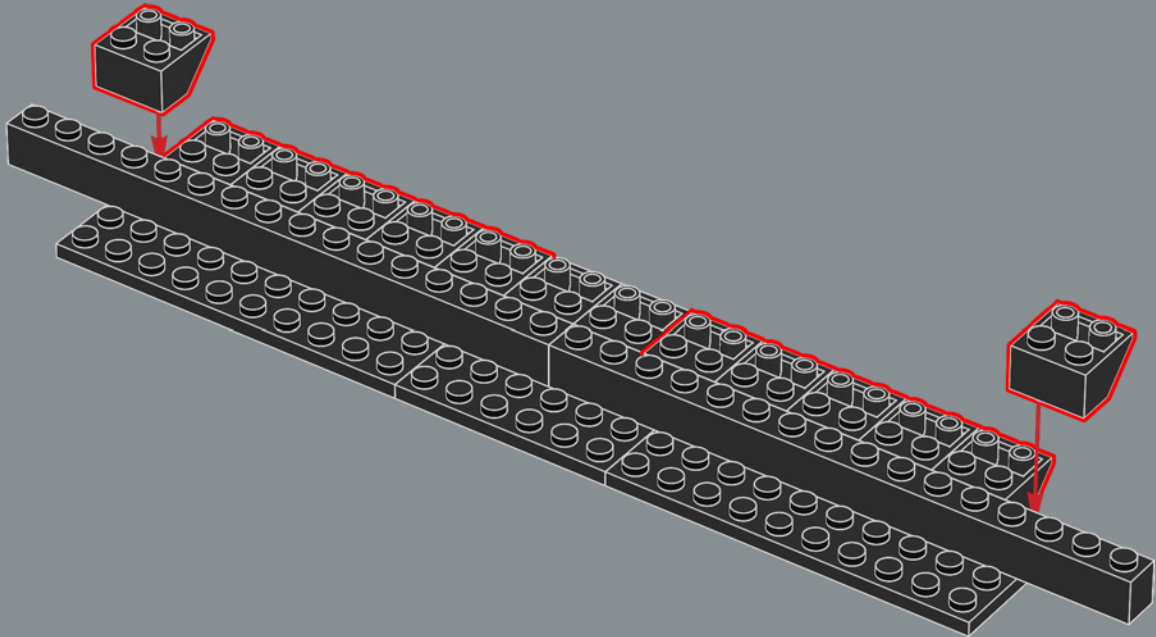

156

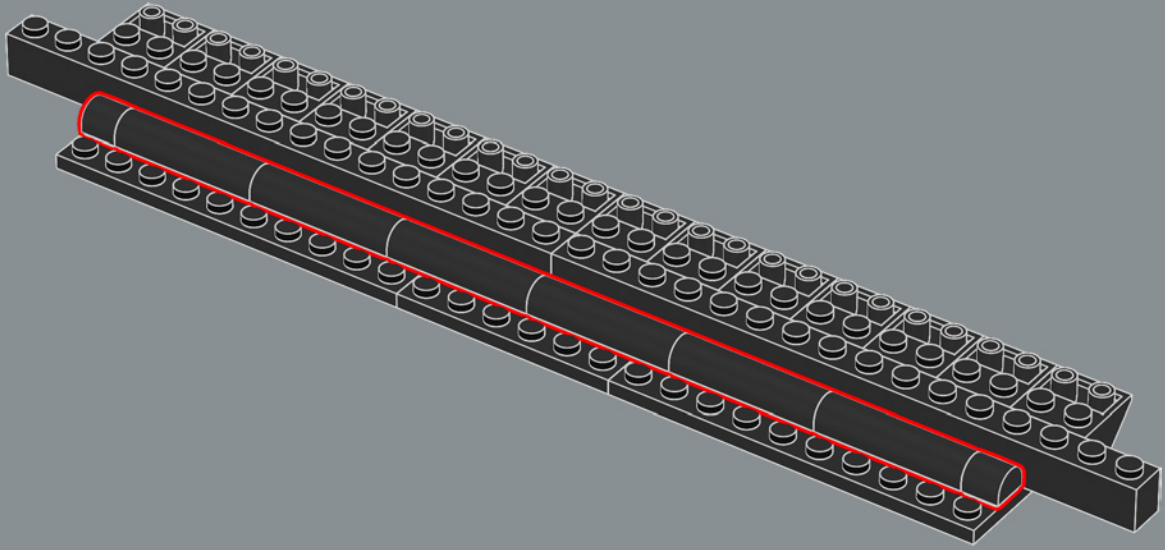

2x

157

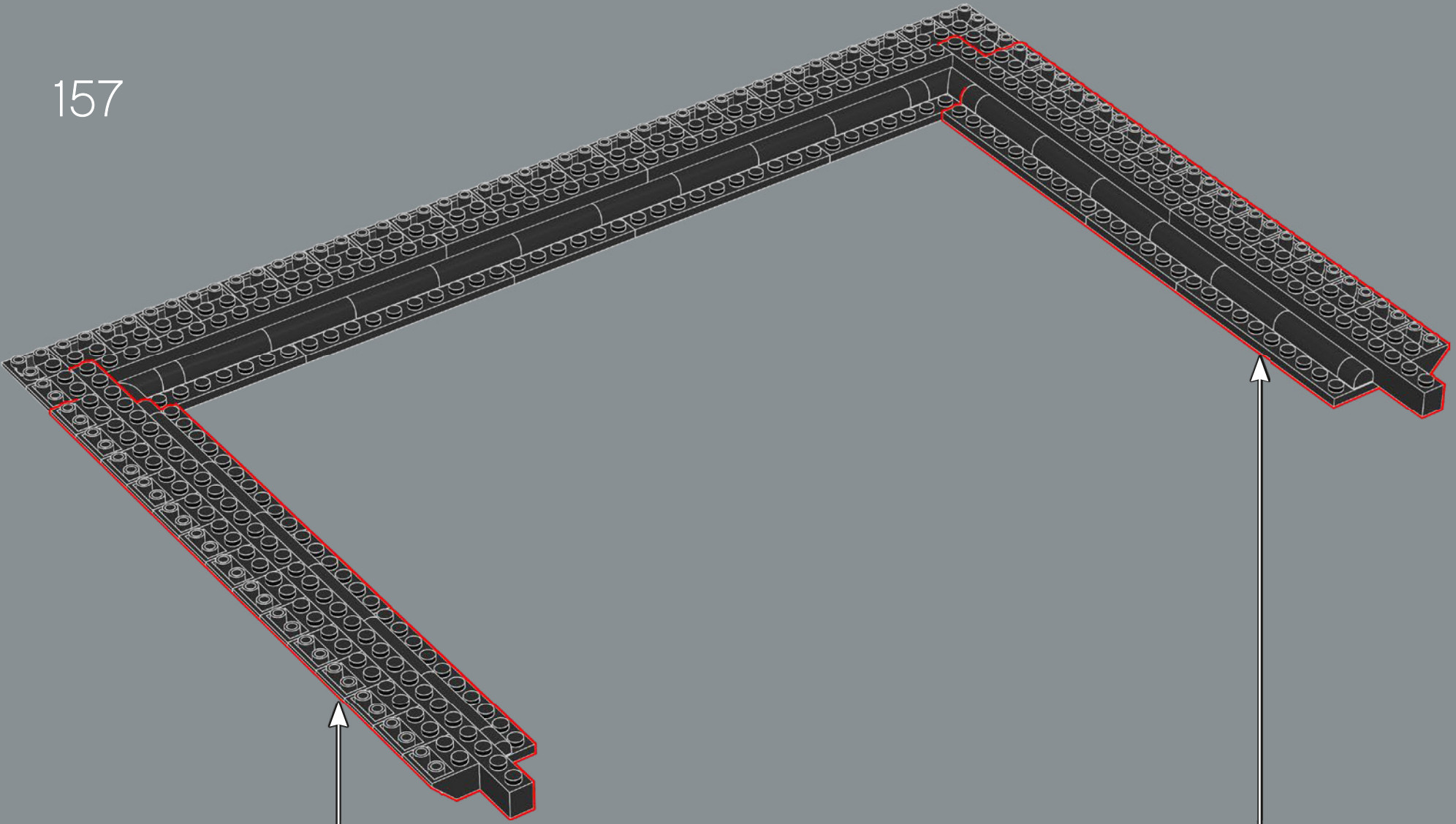

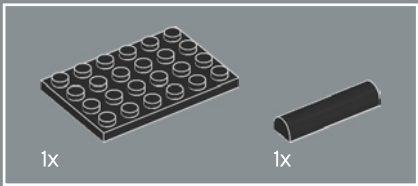
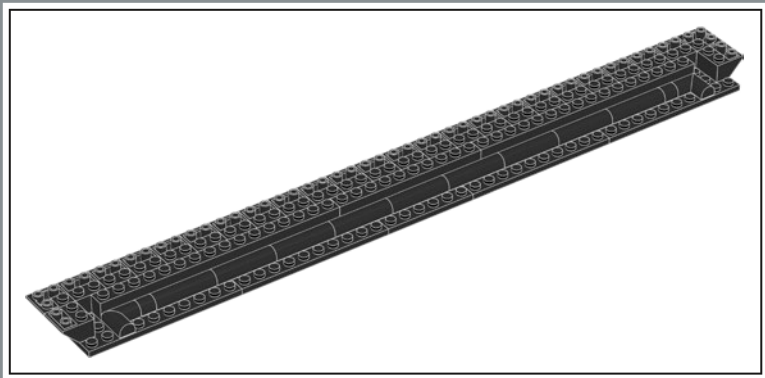

158

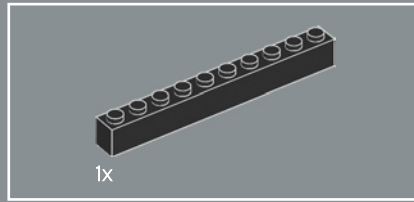
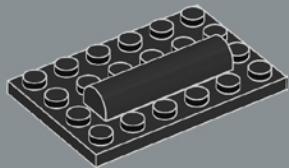

159

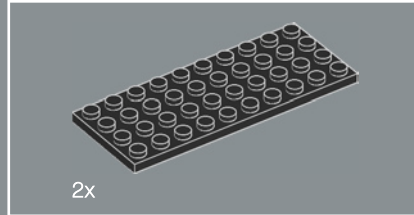
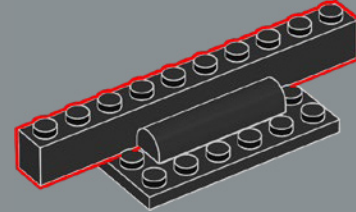

160

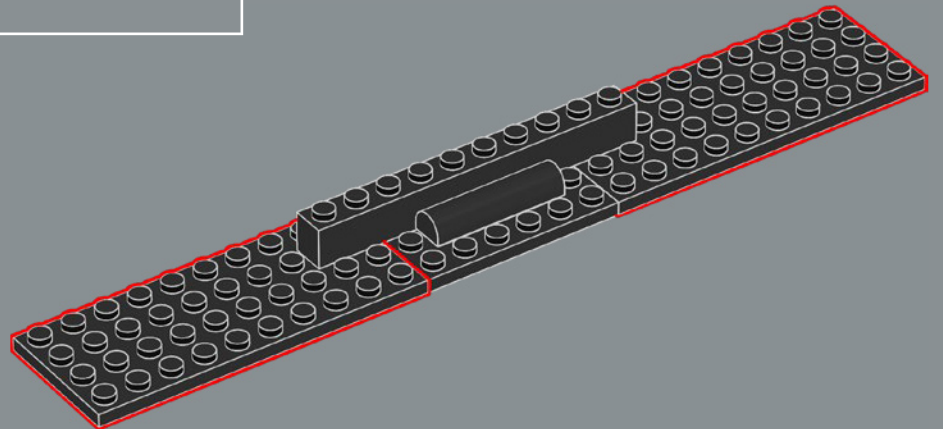

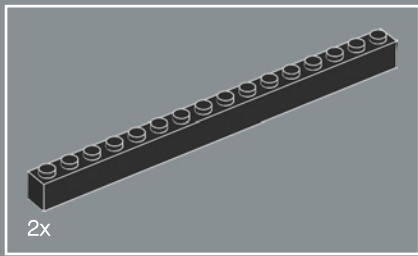

161

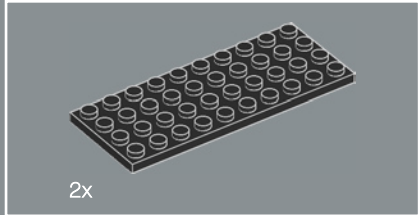
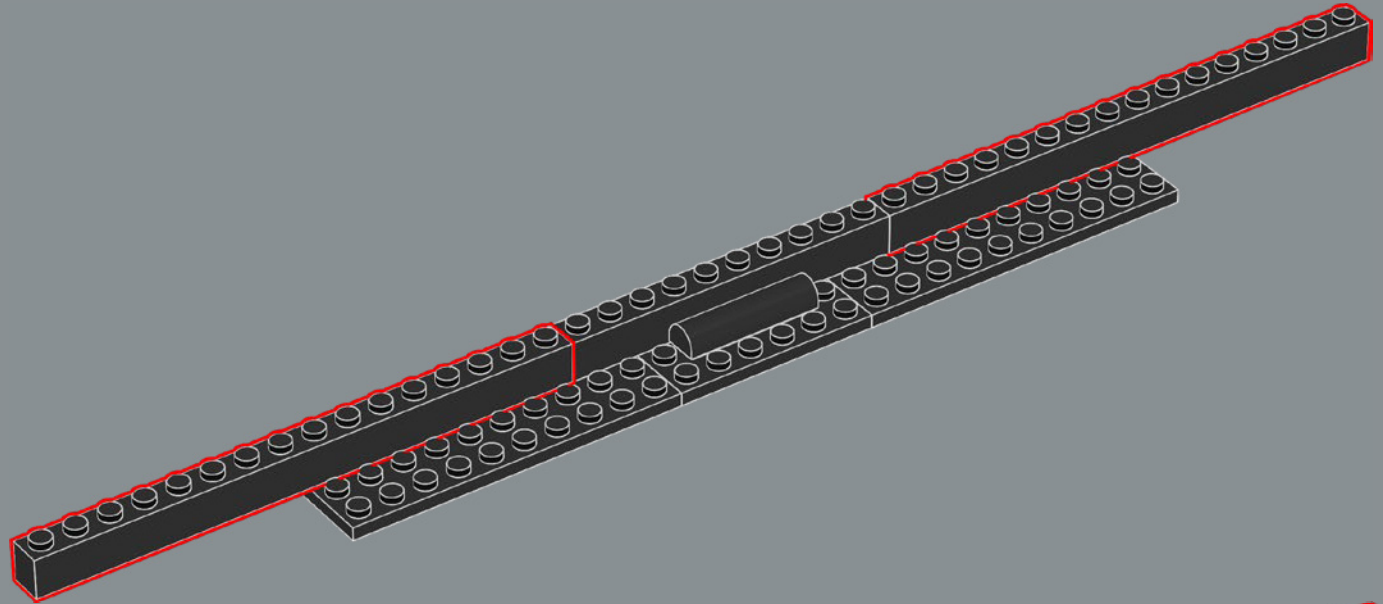

162

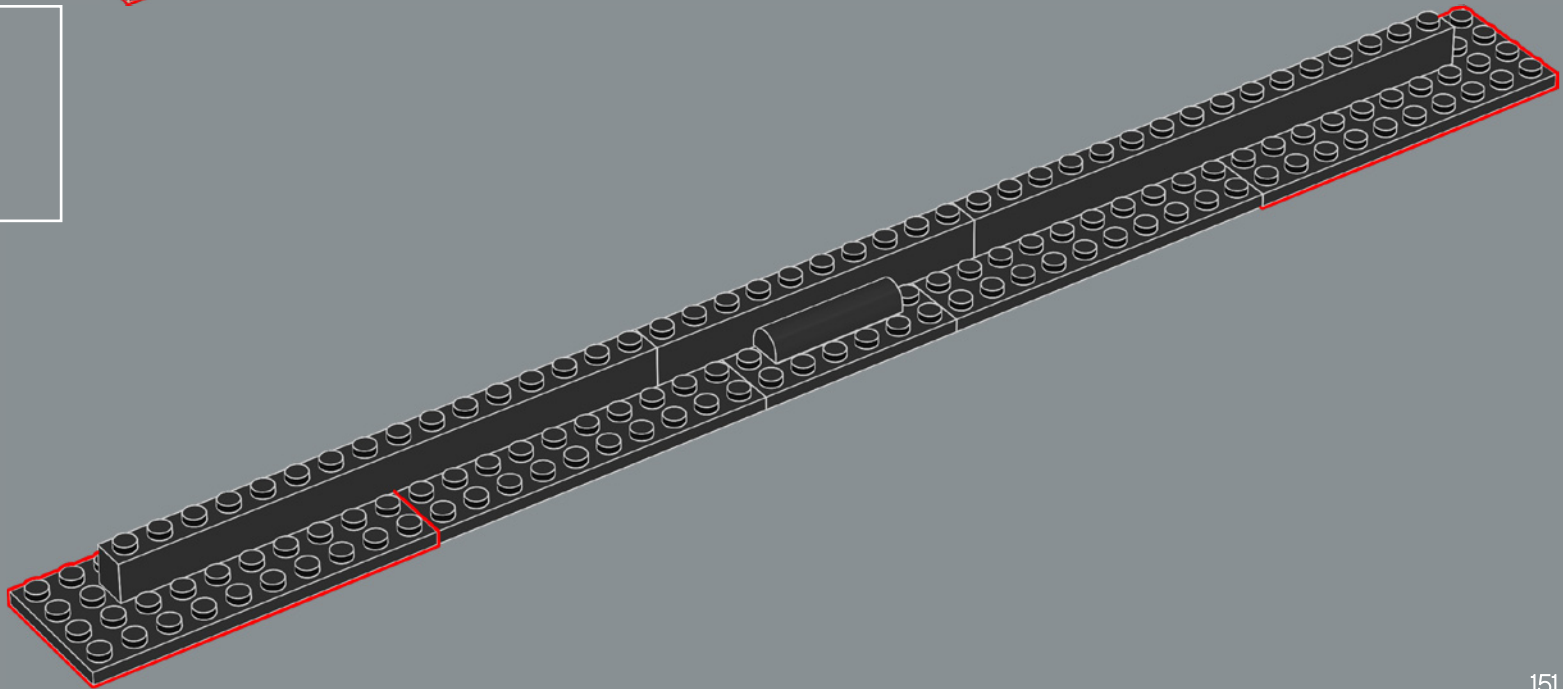



163

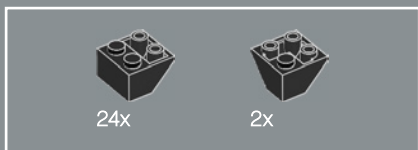
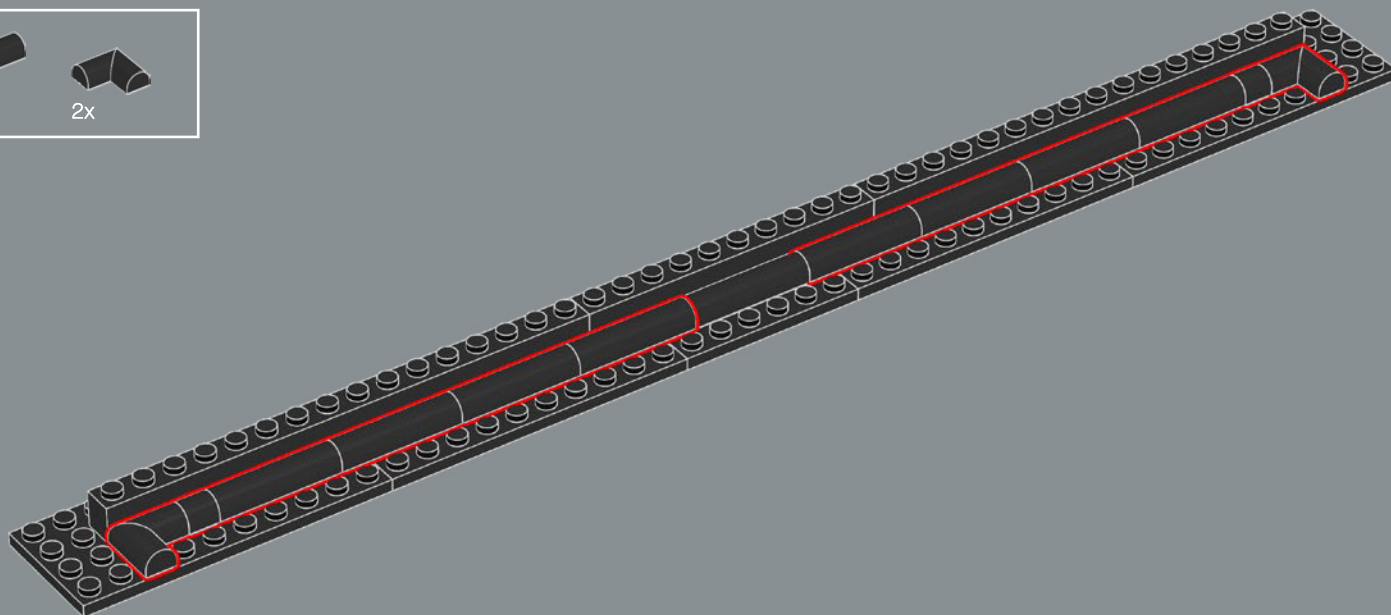

164

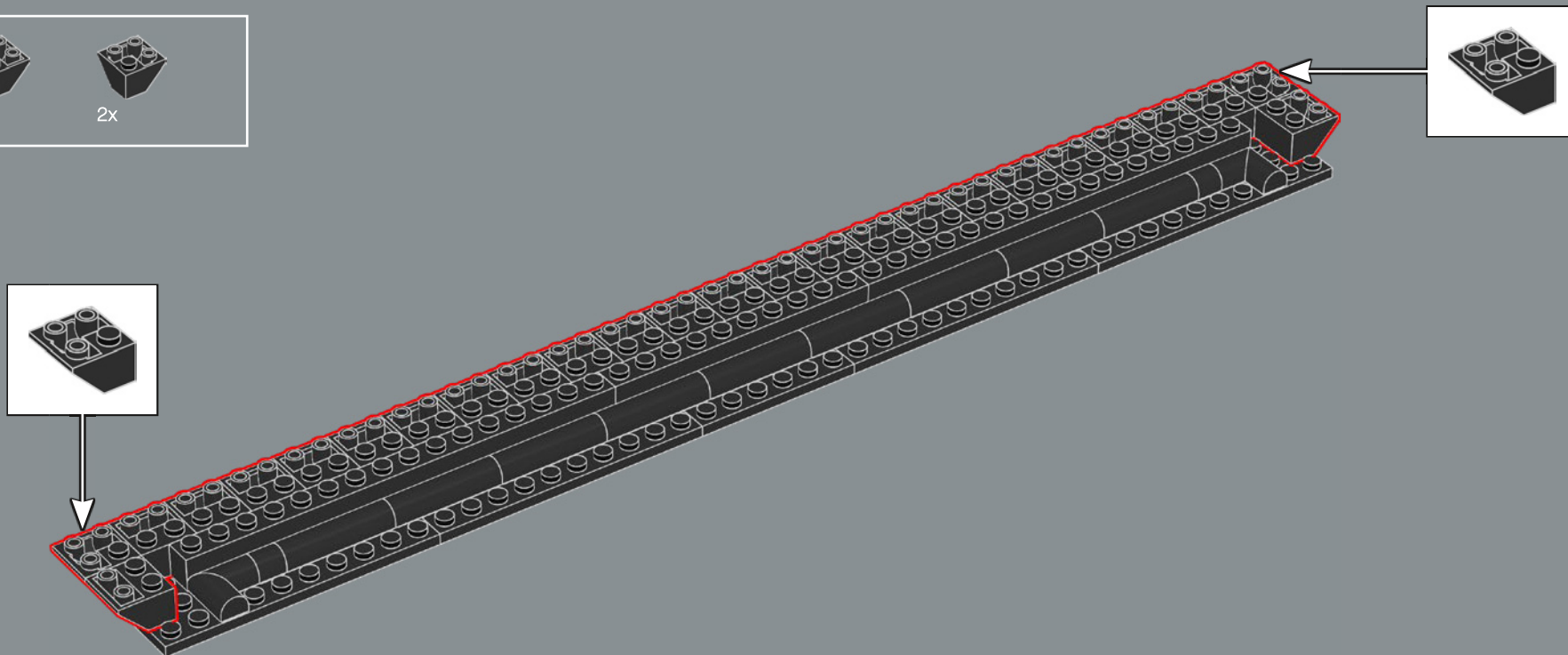

165

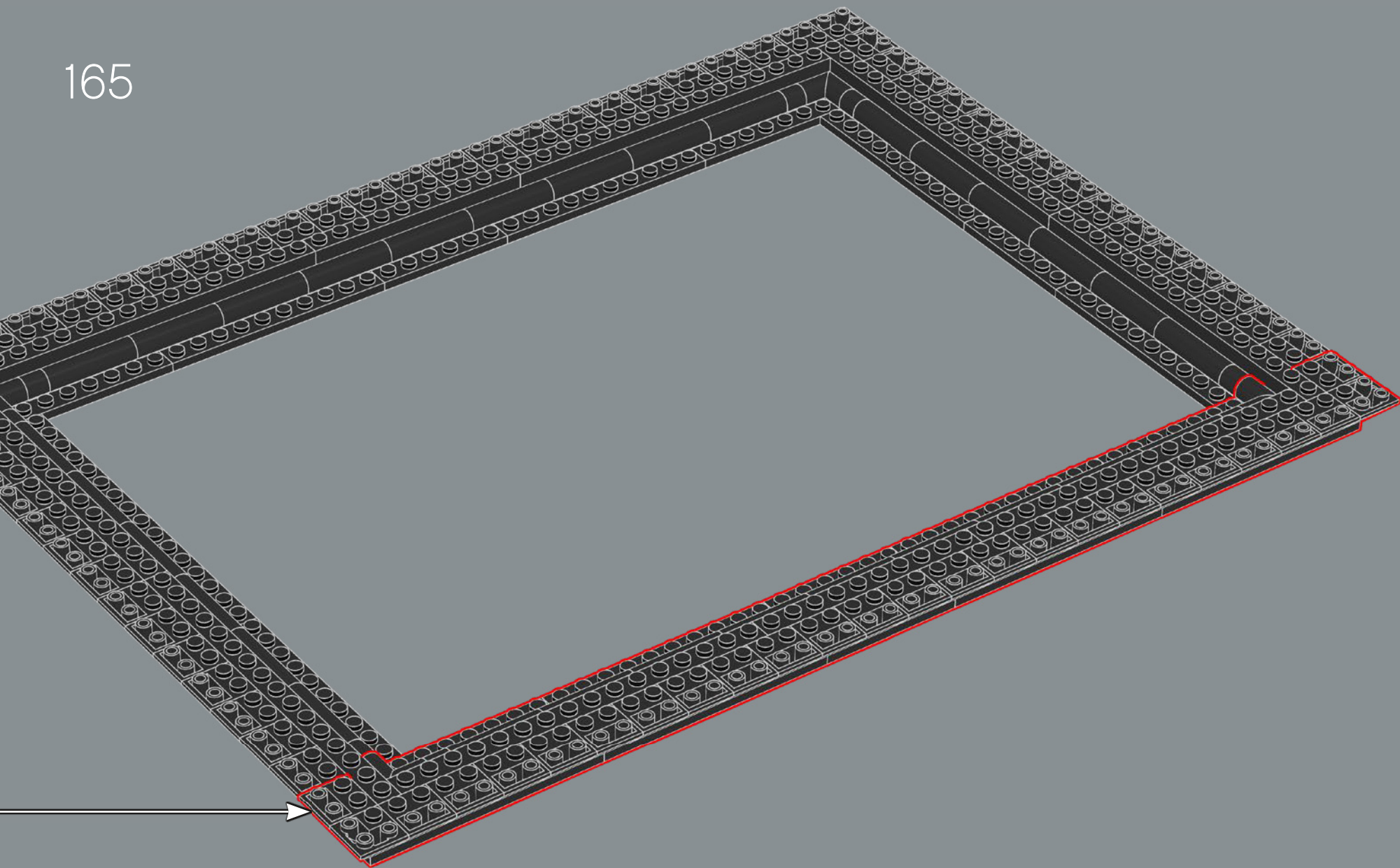

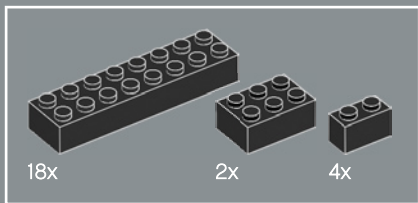

166

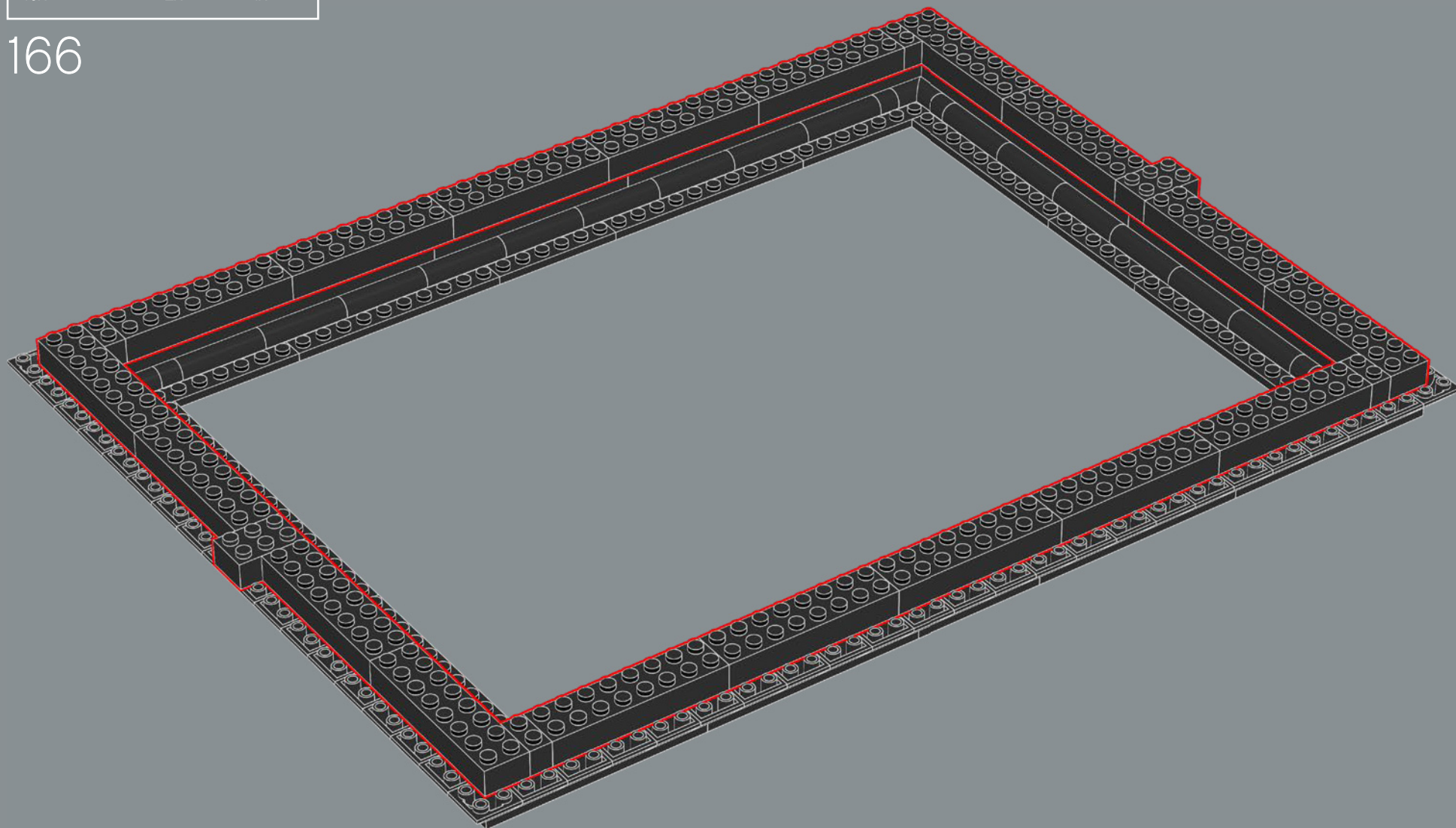

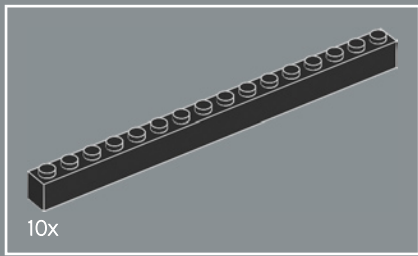

167

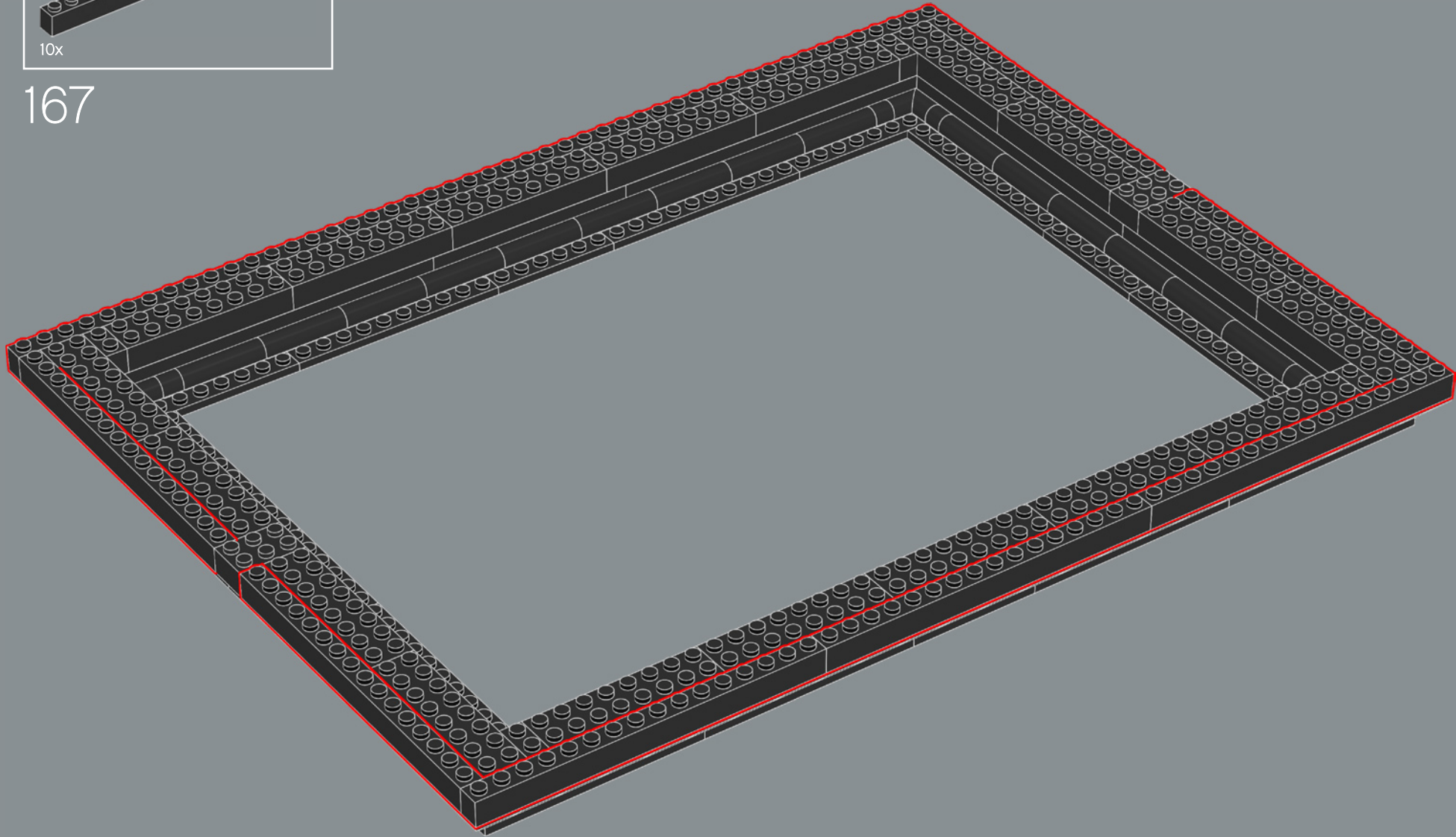

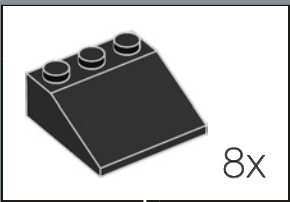
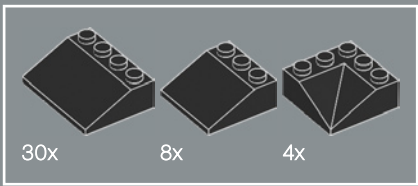

168

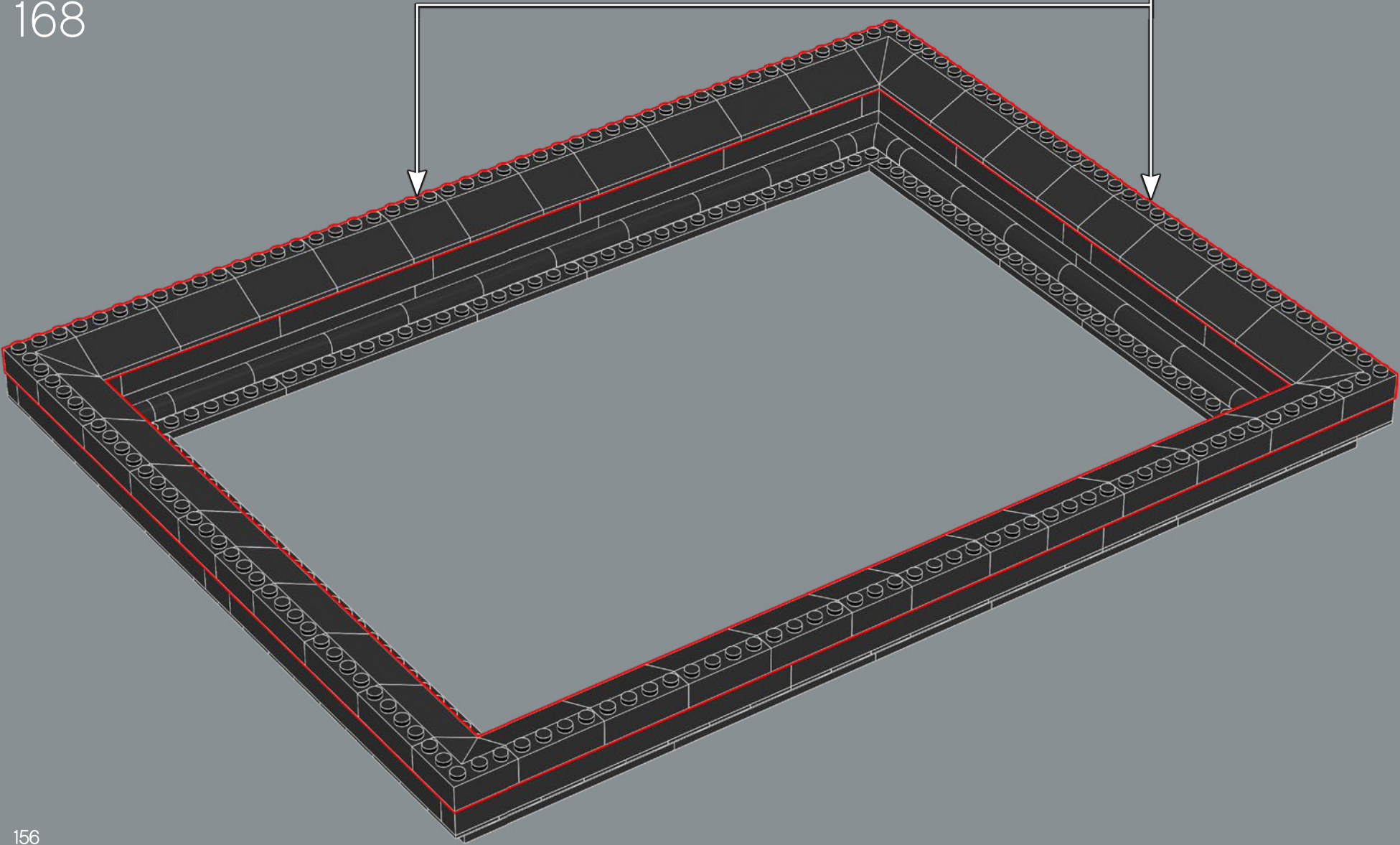

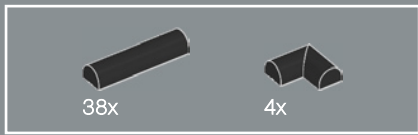

169

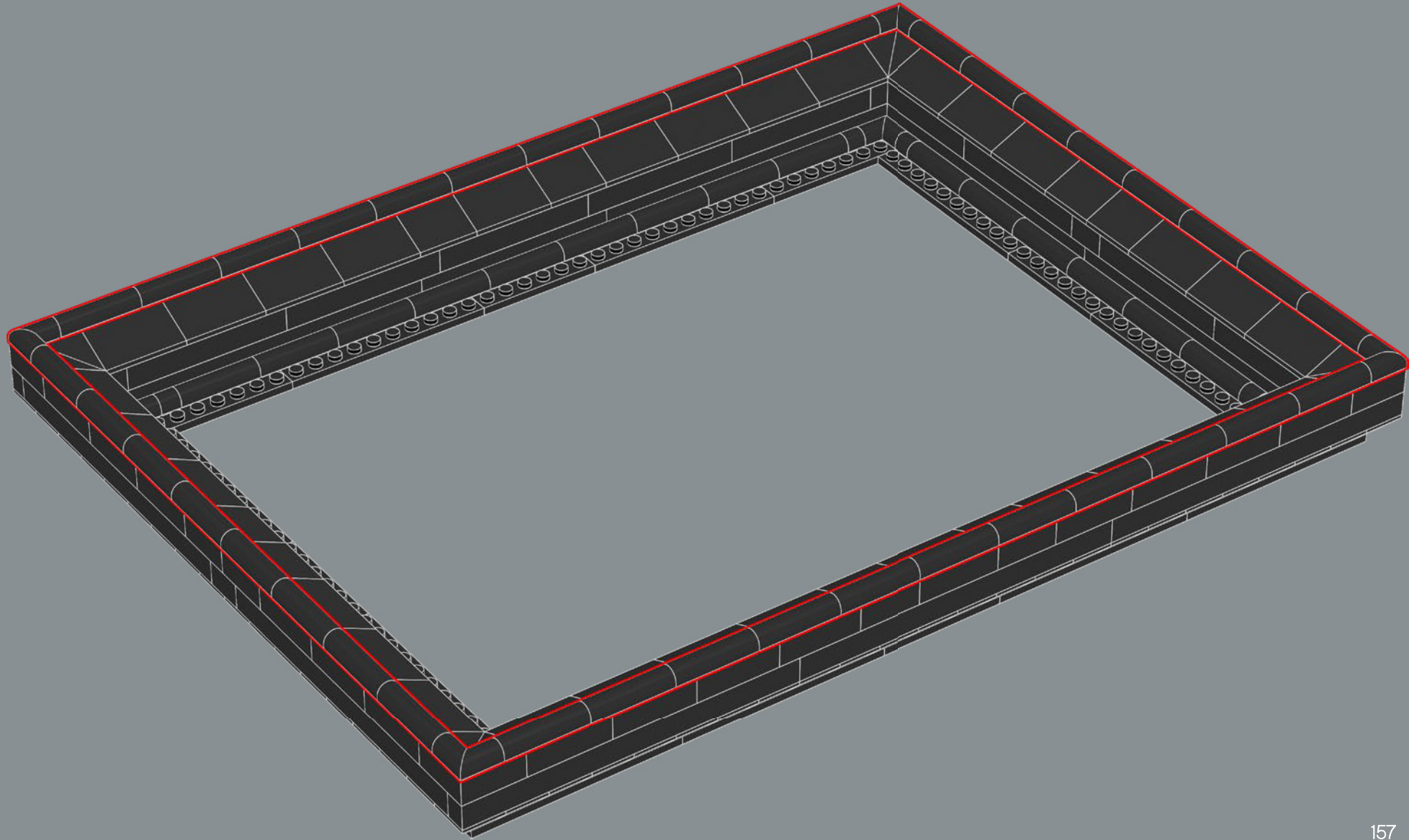

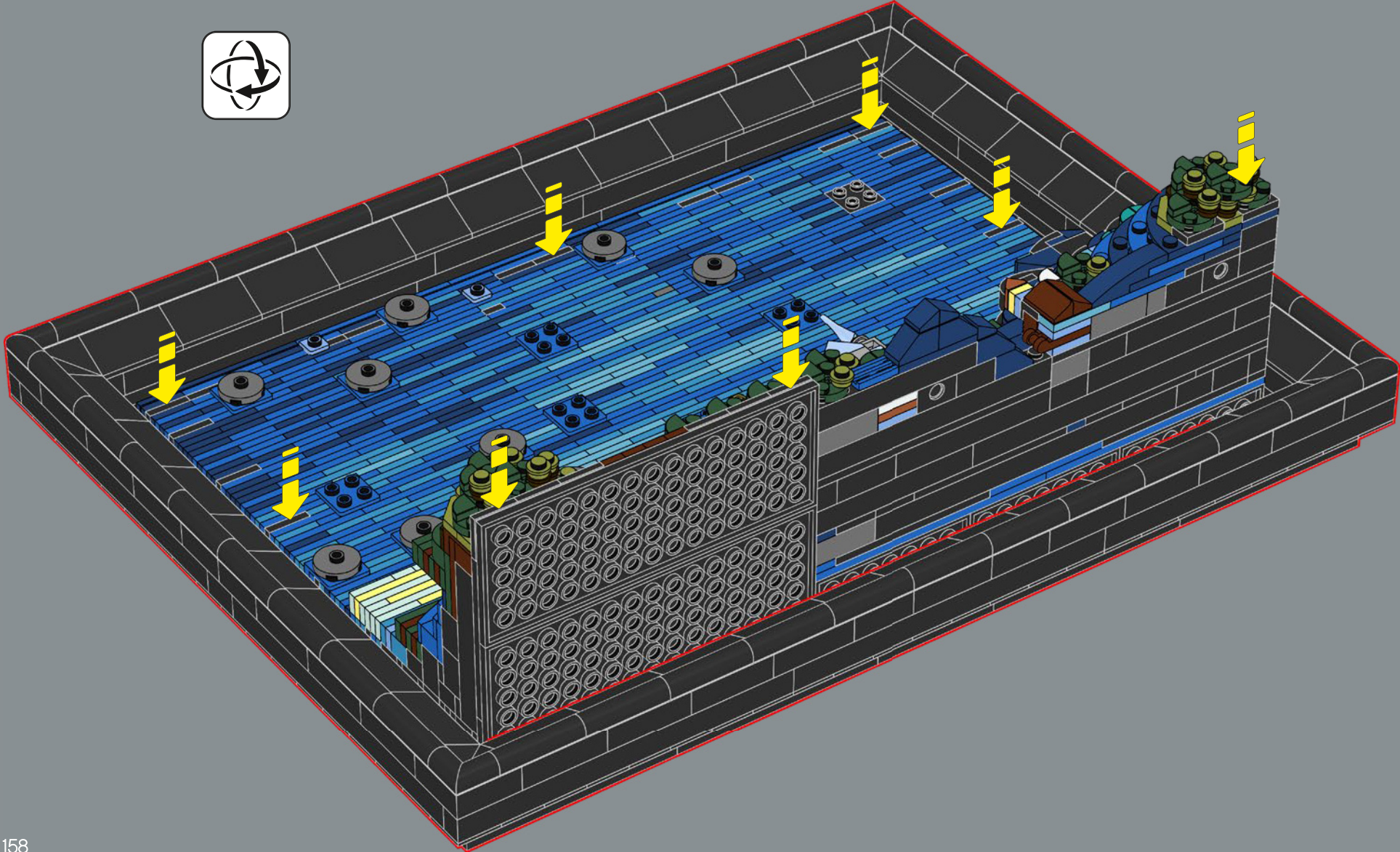



171

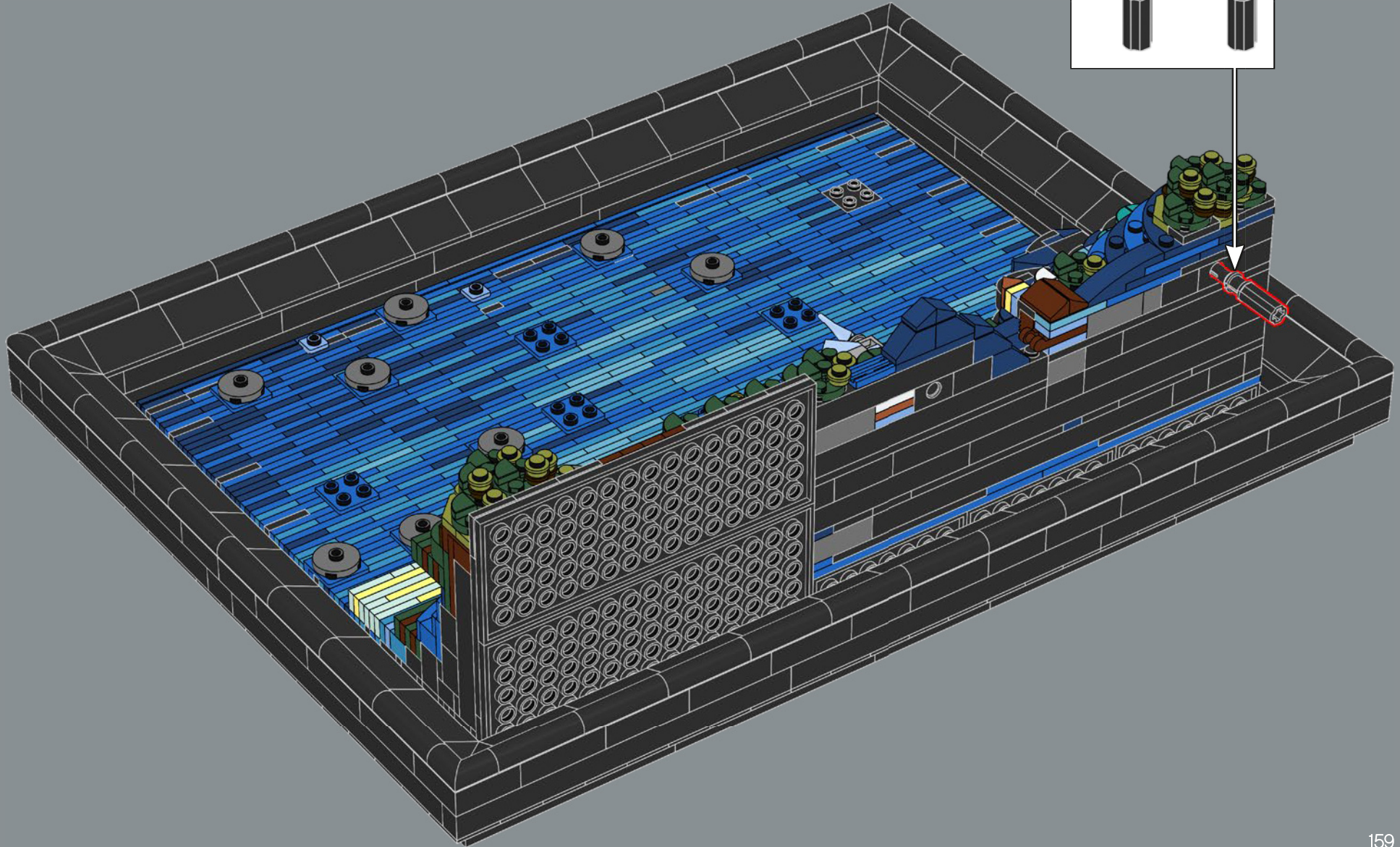
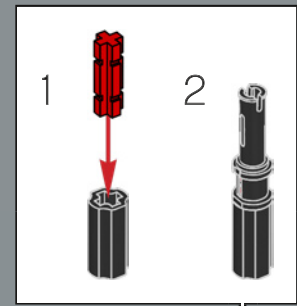

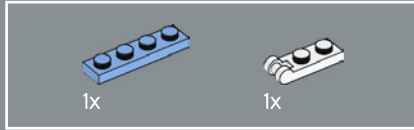
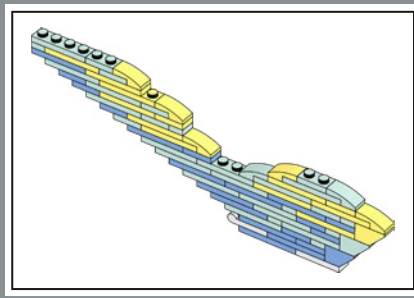

172

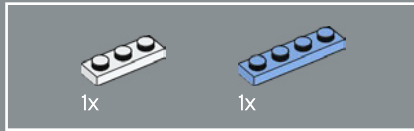
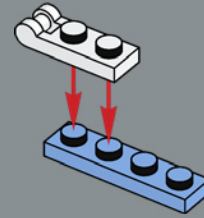

173

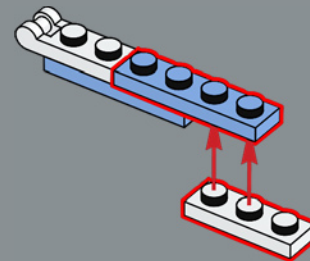

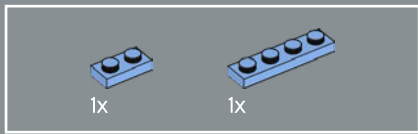

174

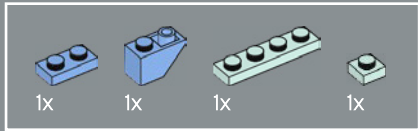
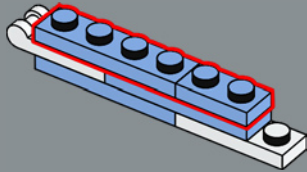

175

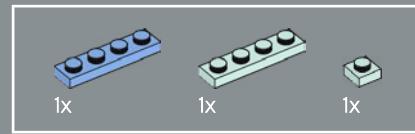
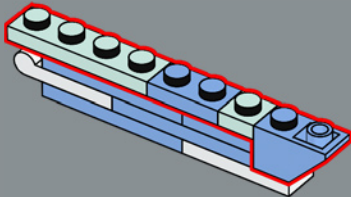

176

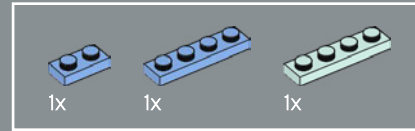
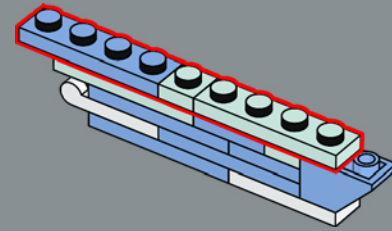

177

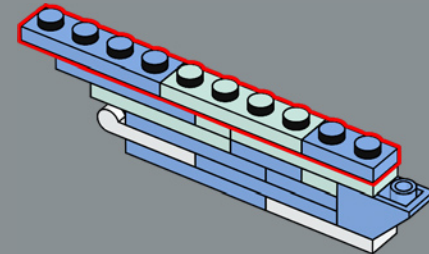

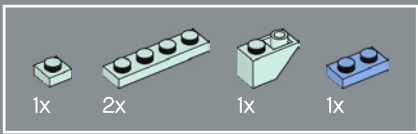

178

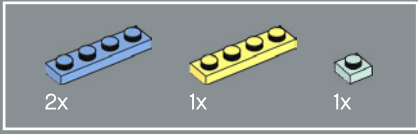
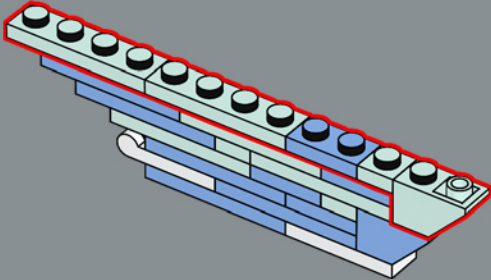

179

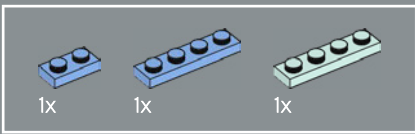
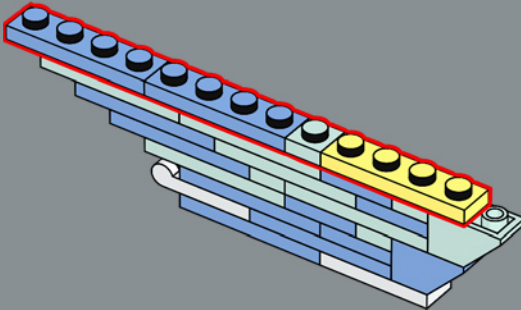

180

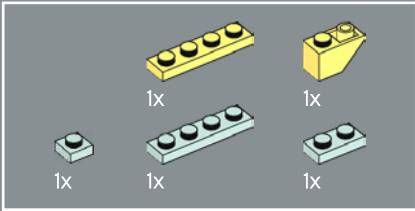
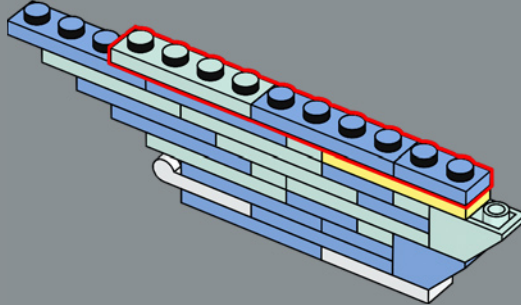

181

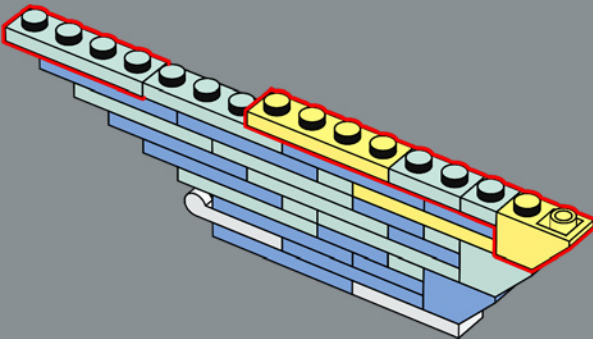

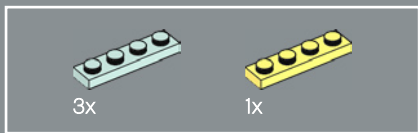

182

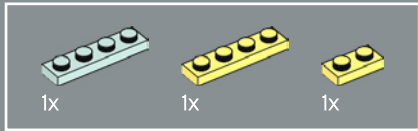
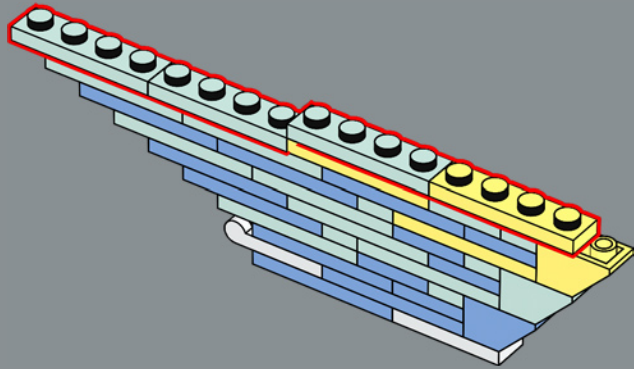

183

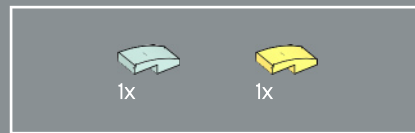
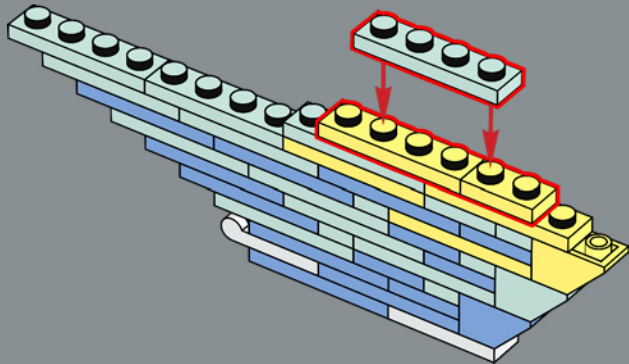

184

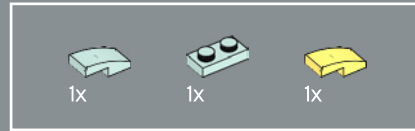
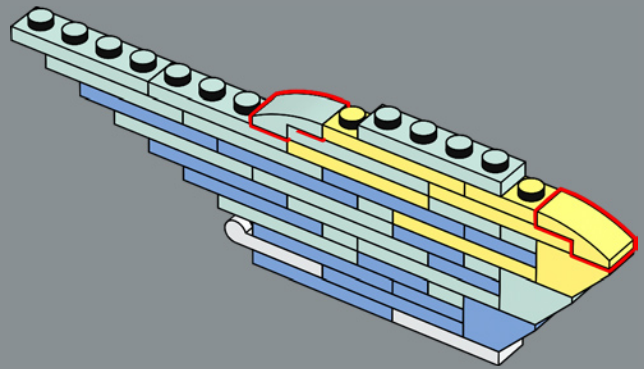

185

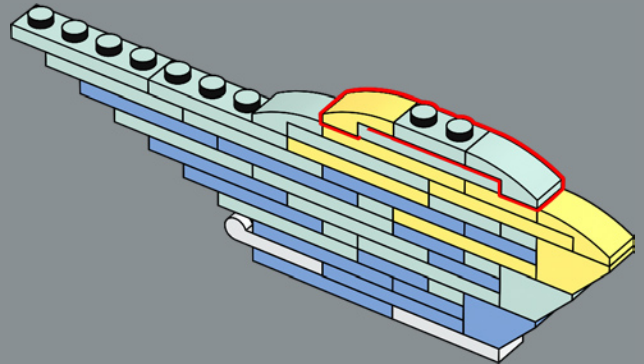

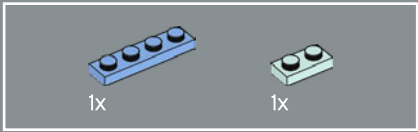
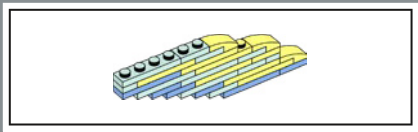

186

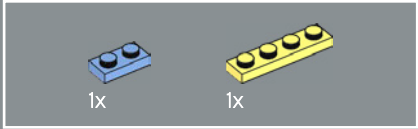
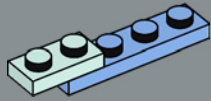

187

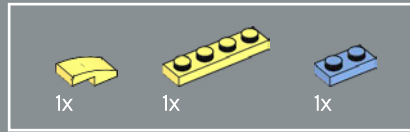
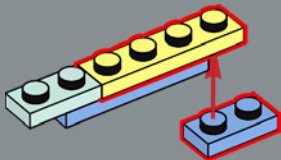

188

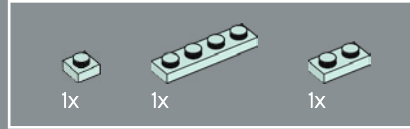
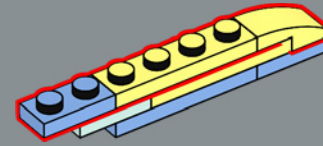

189

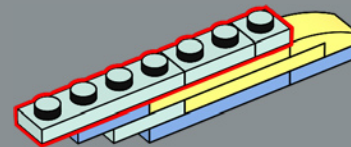

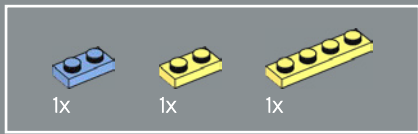

190

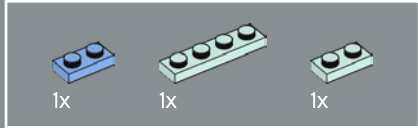
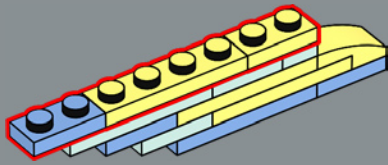

191

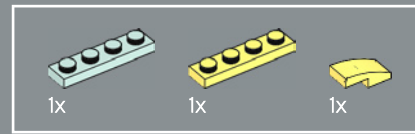
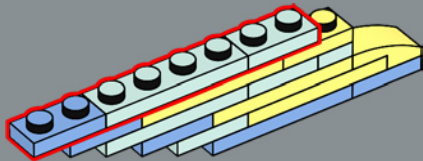

192

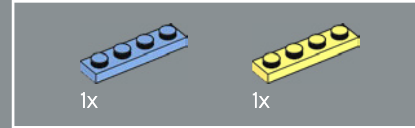
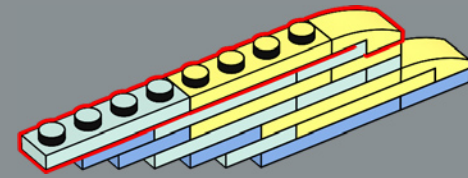

193

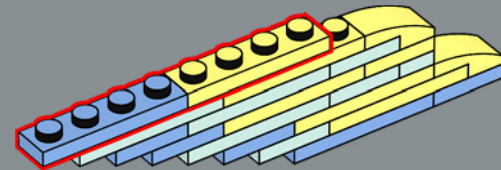

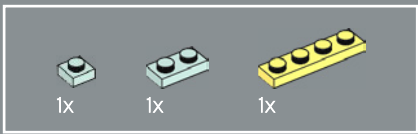

194

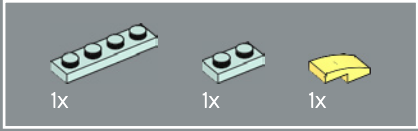
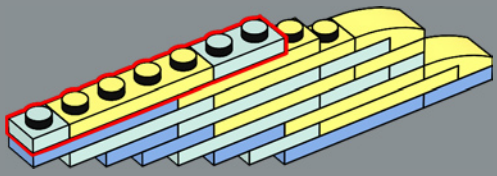

195

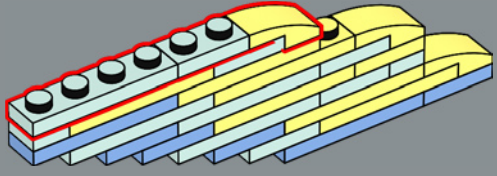

196

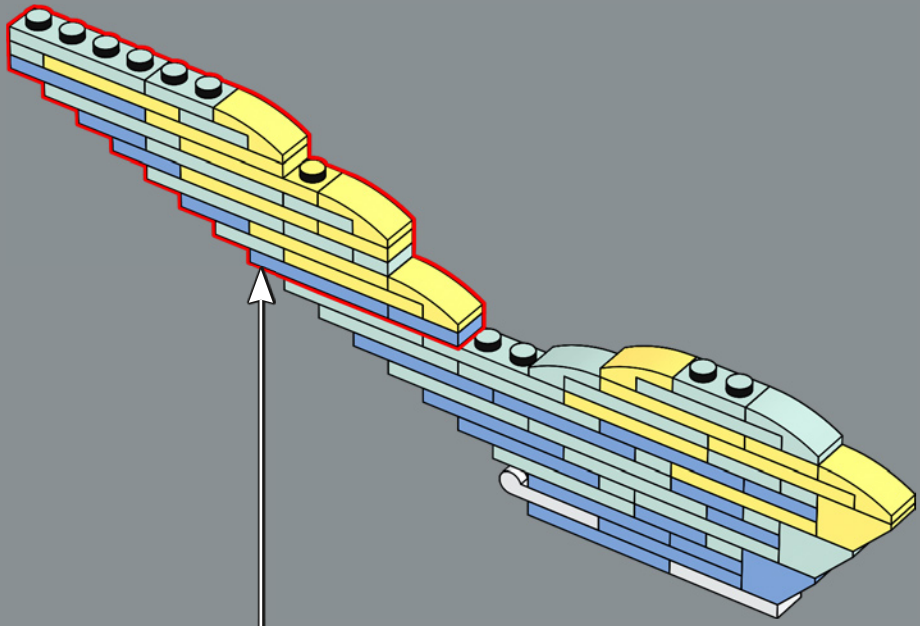

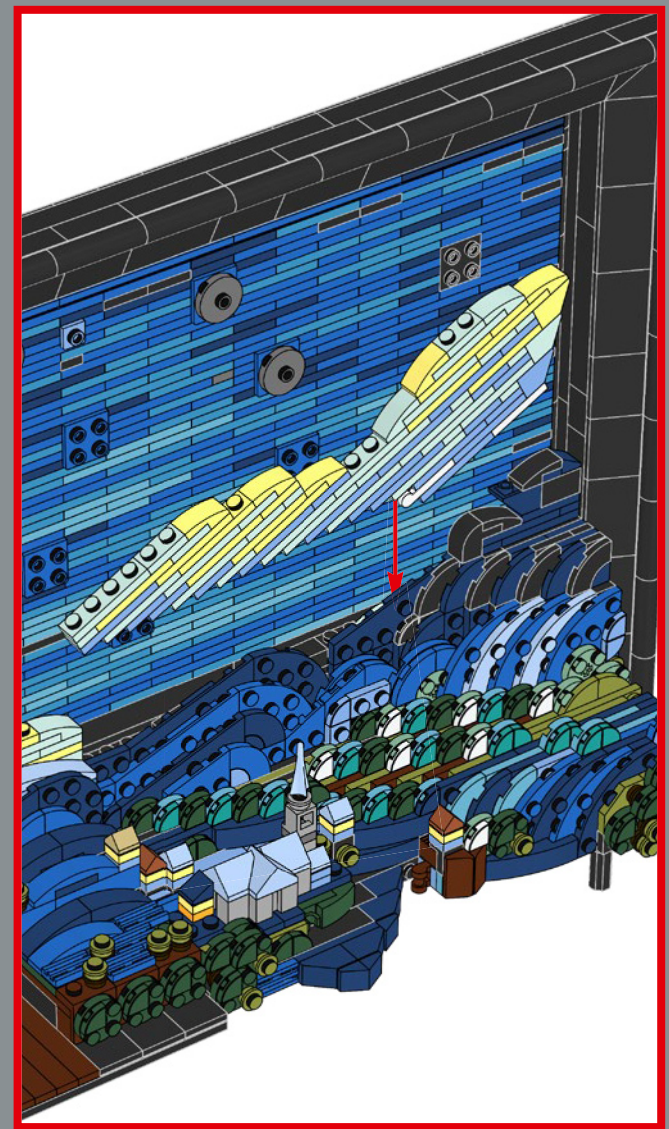
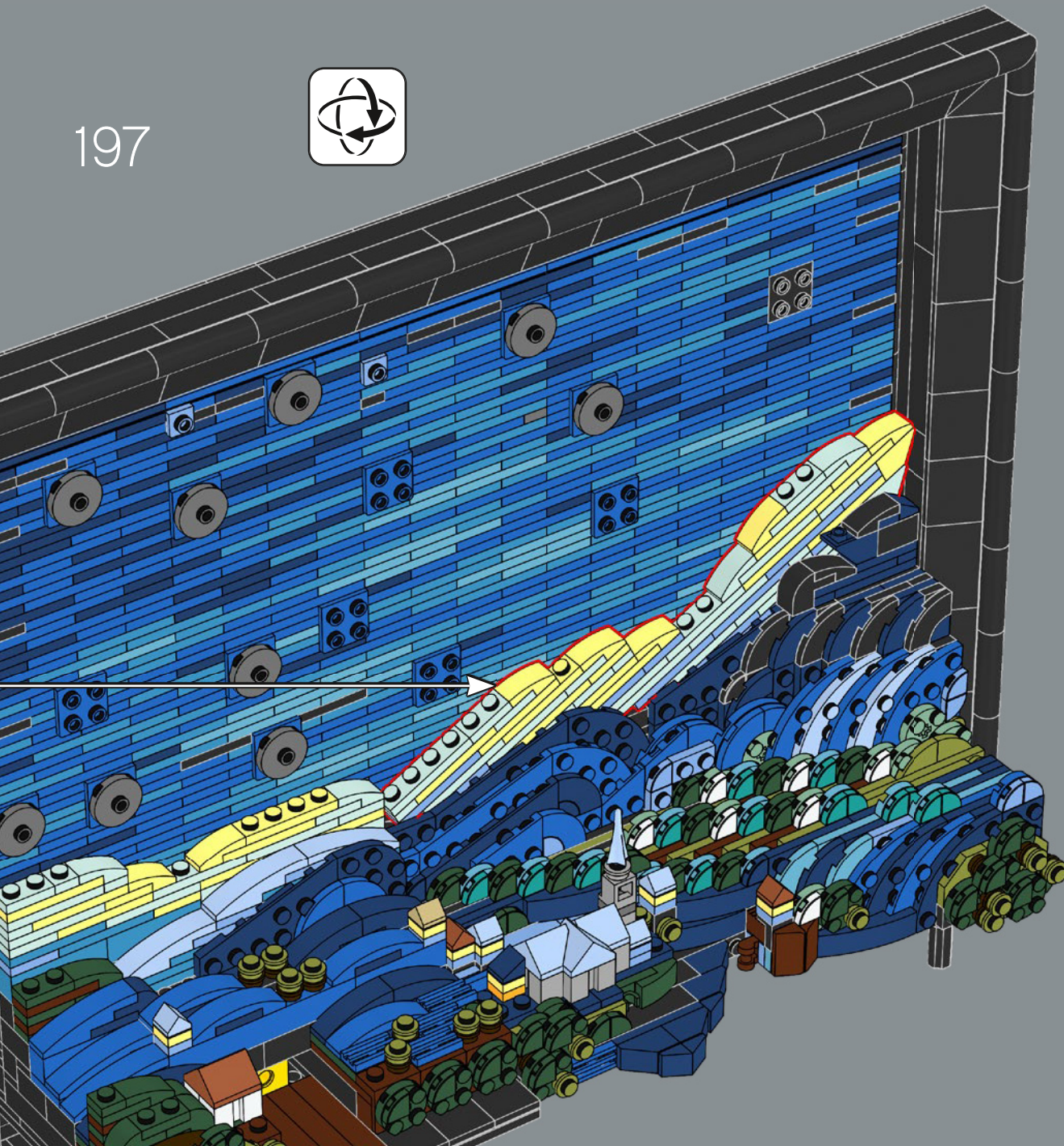

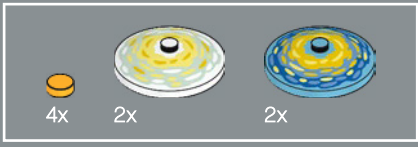

198

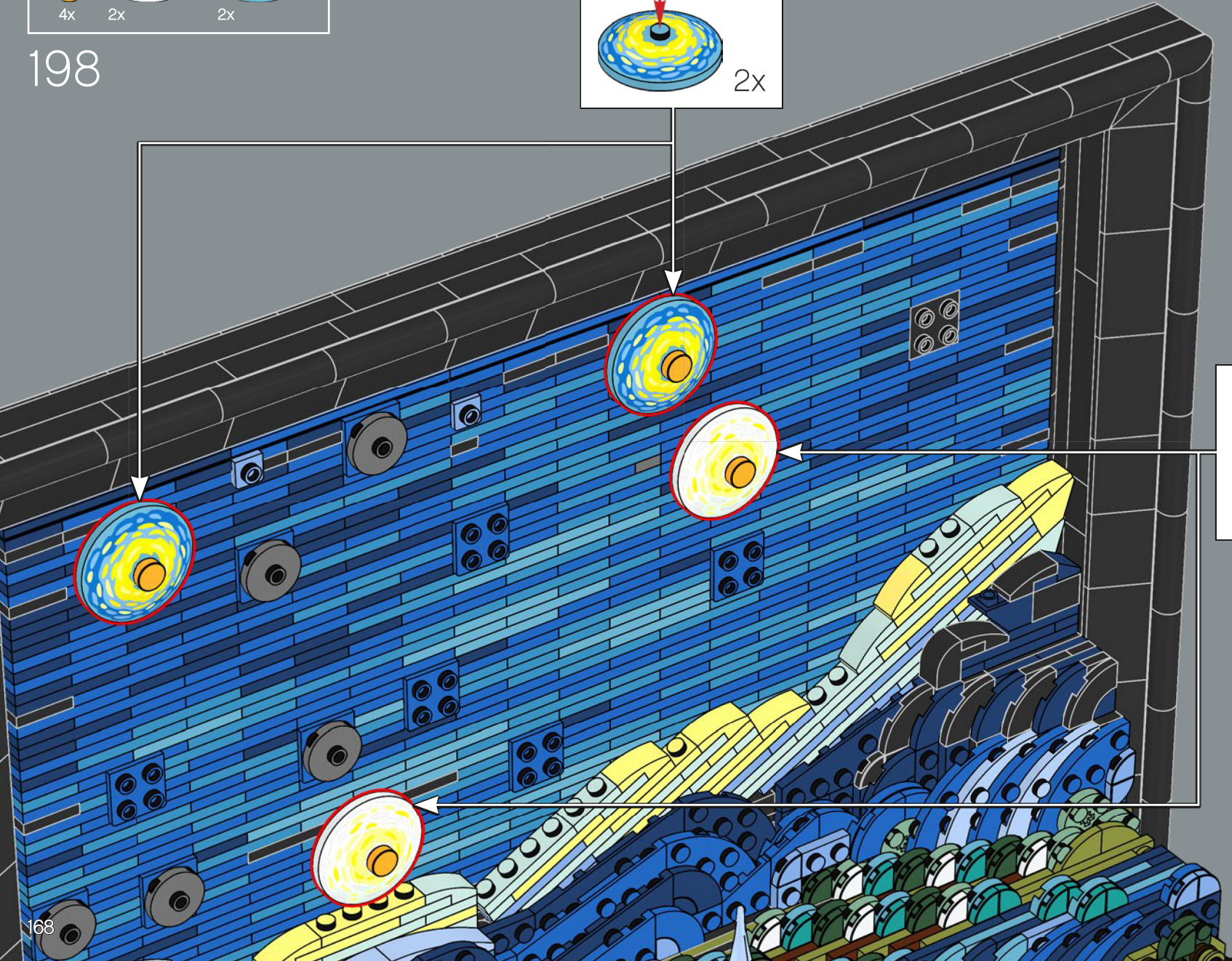
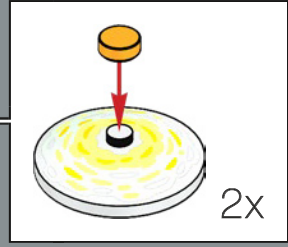
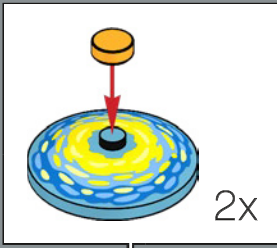

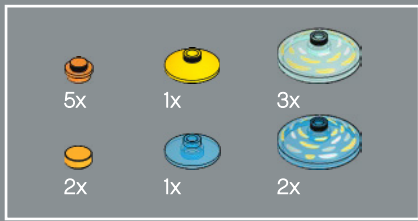

199

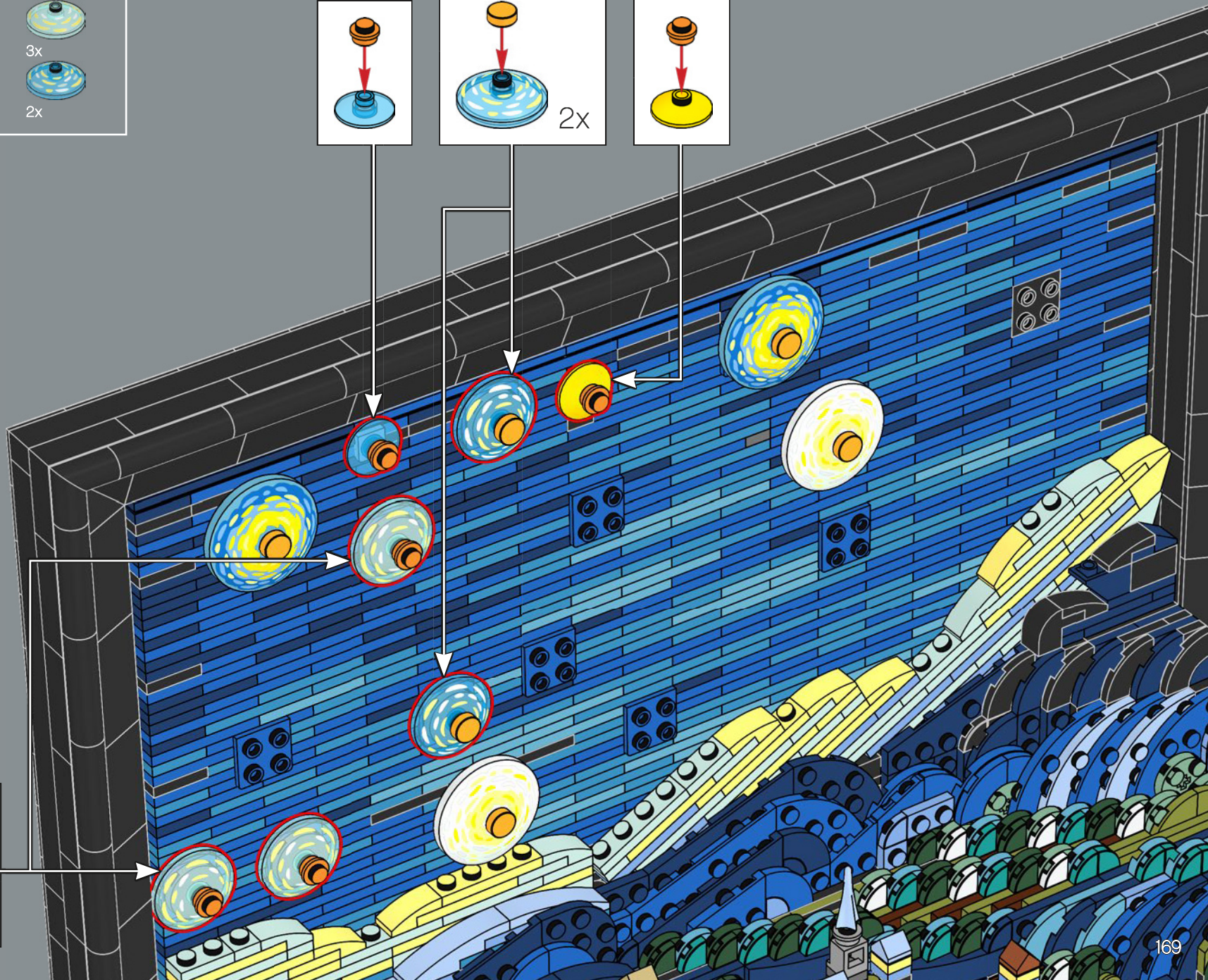
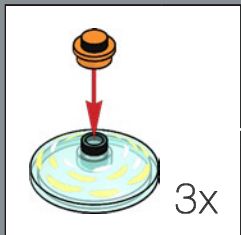
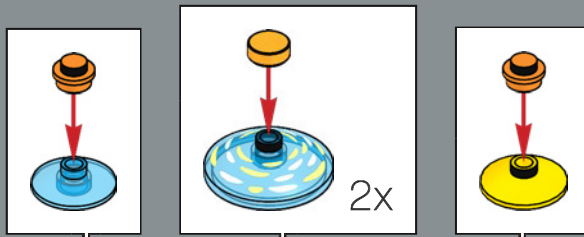

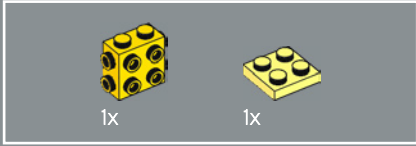
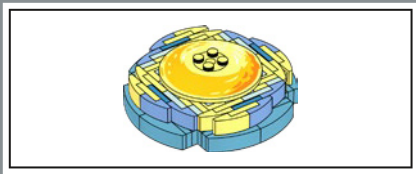

200

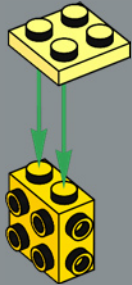

201

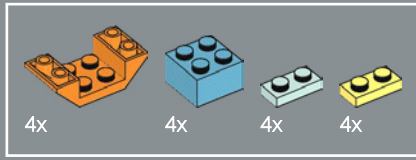

202

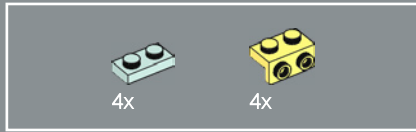
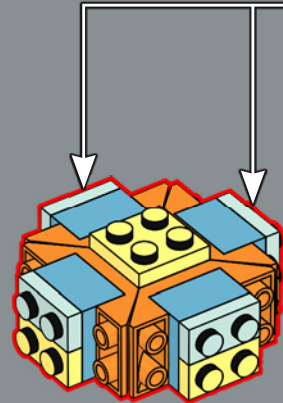
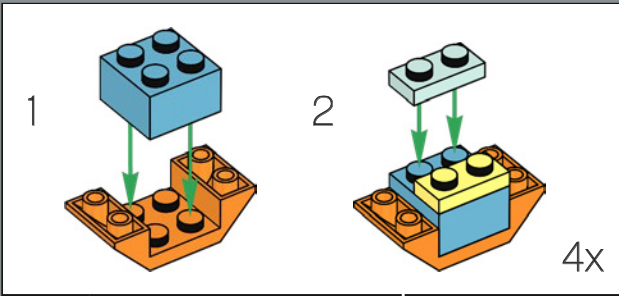

203

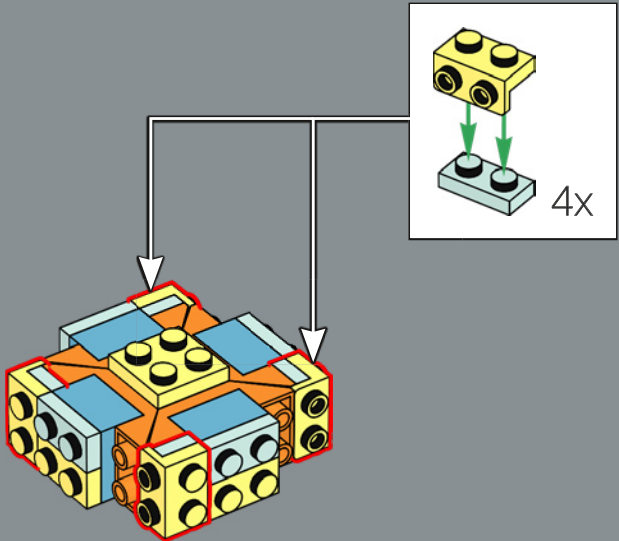



204

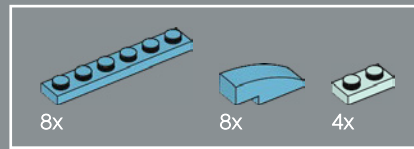
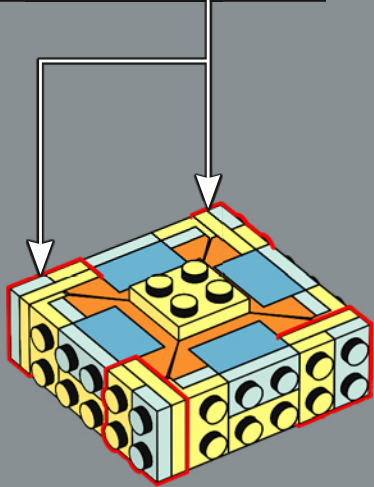
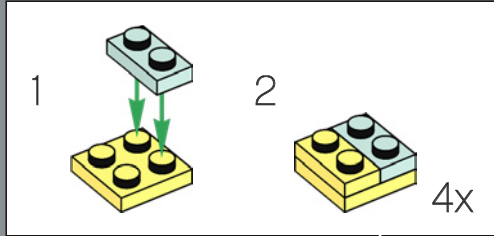

205

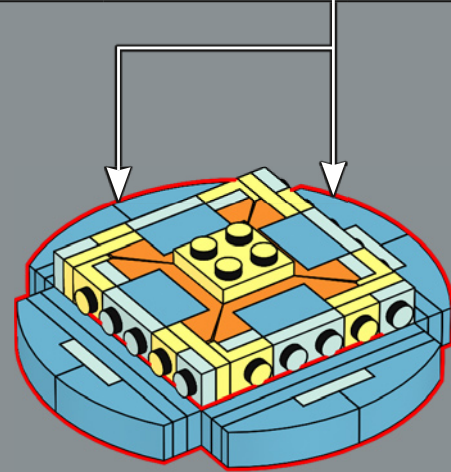
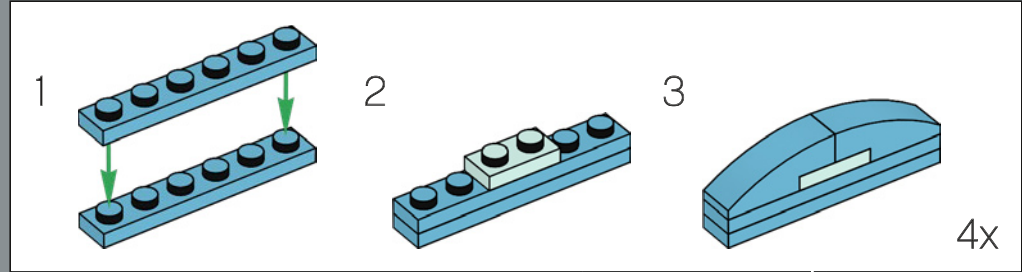

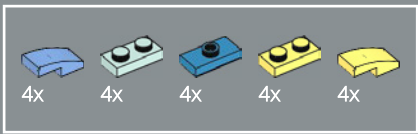

206

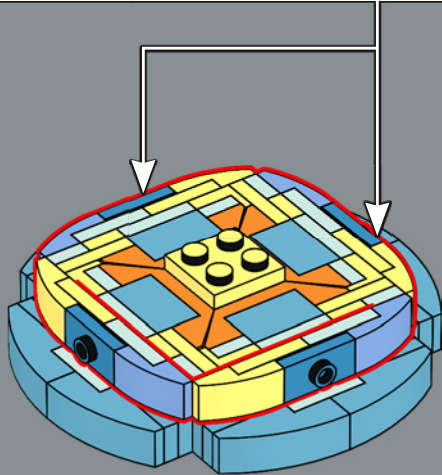
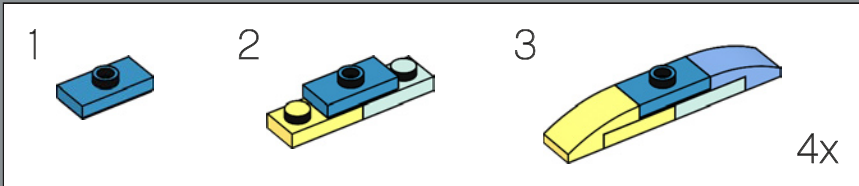

207

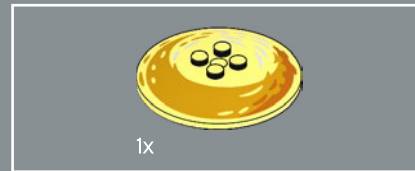
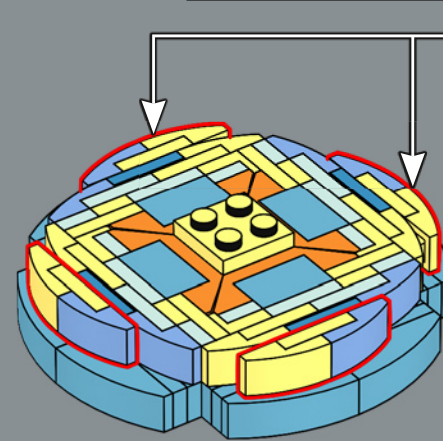
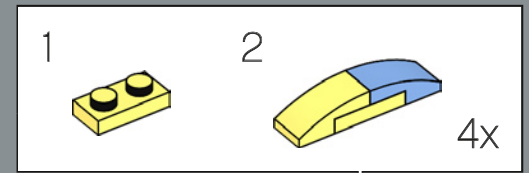

208

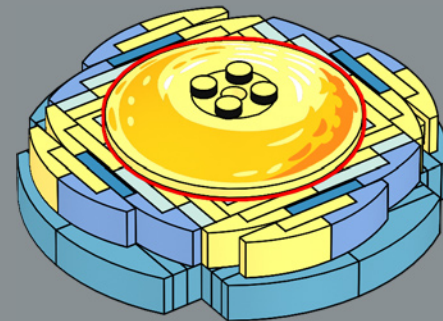

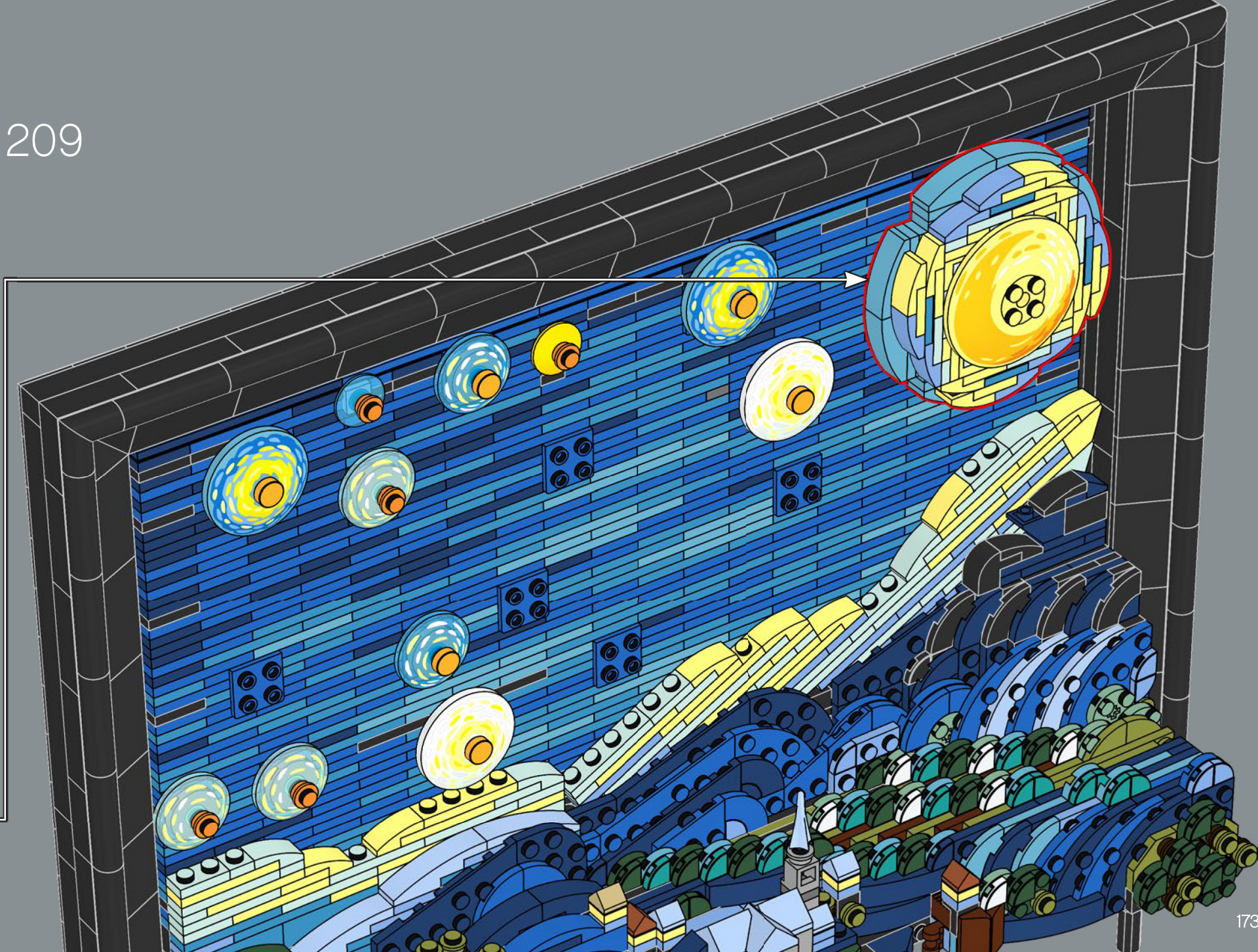

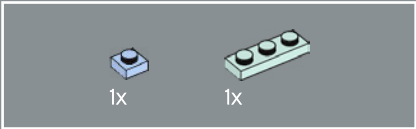
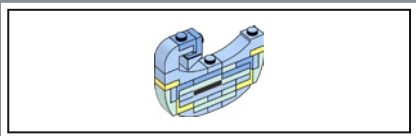

210

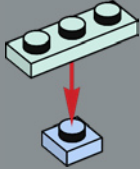

211

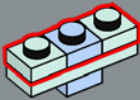



212

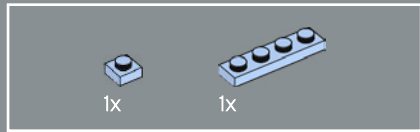
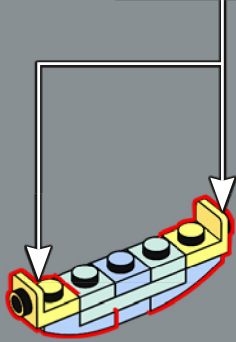
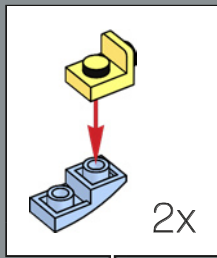

213

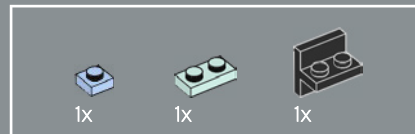
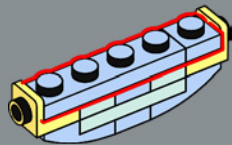

214

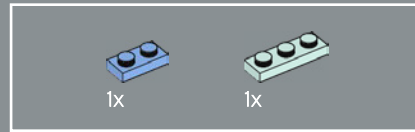
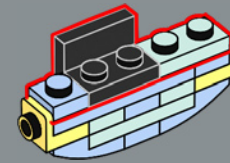

215

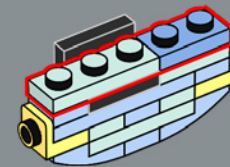



216

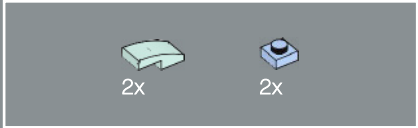
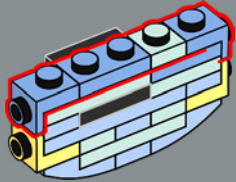

217

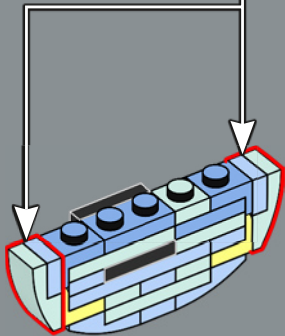
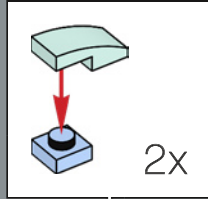

218

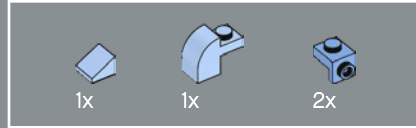
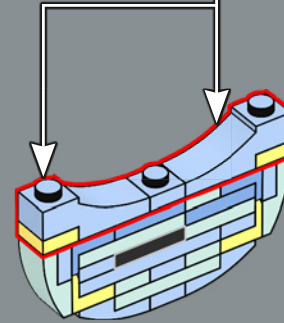
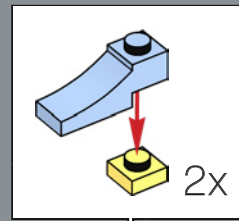

219

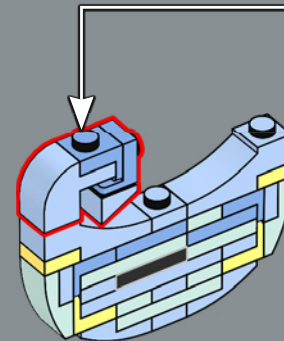
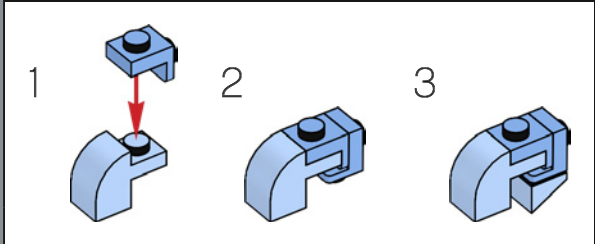

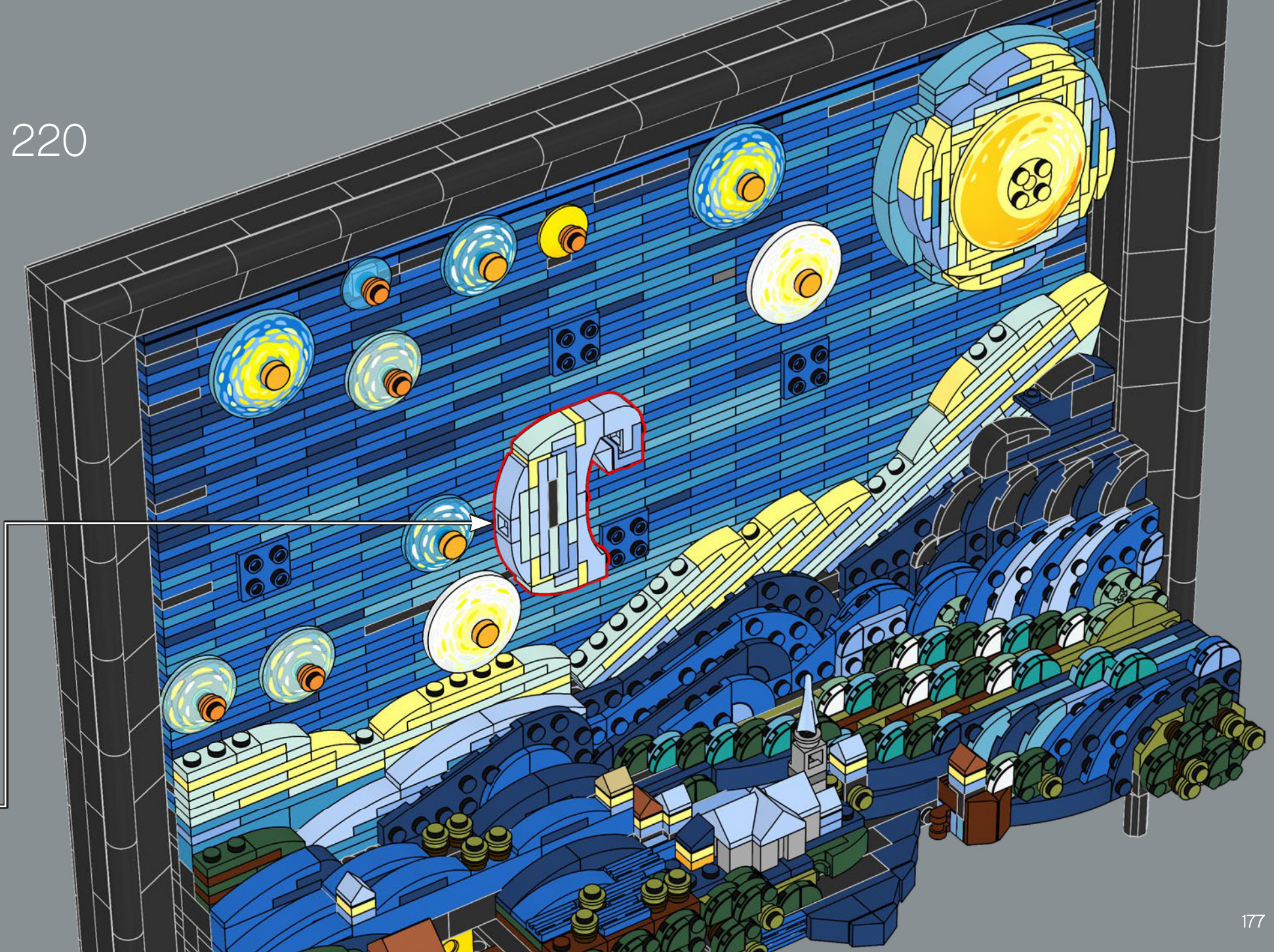

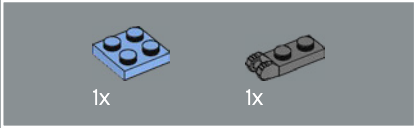
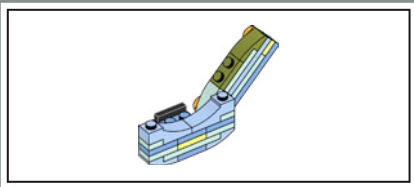

221

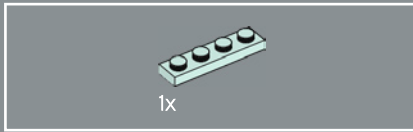
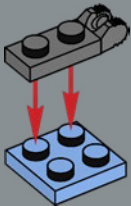

222

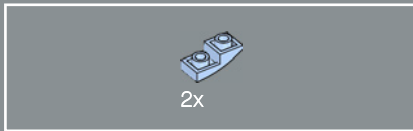
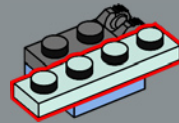

223

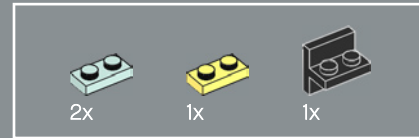
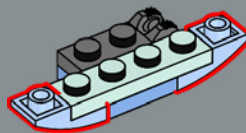

224

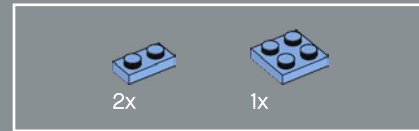
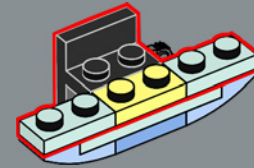

225

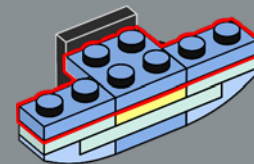



226

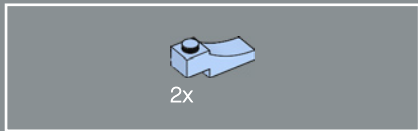
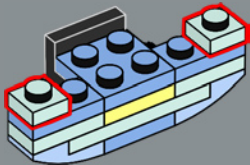

227

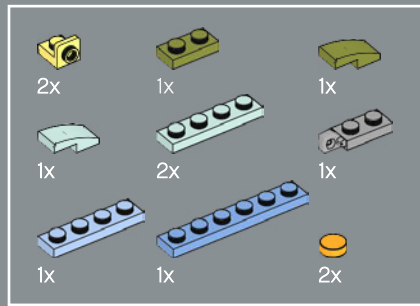
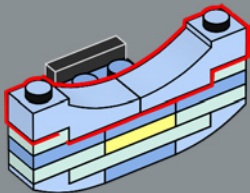

228

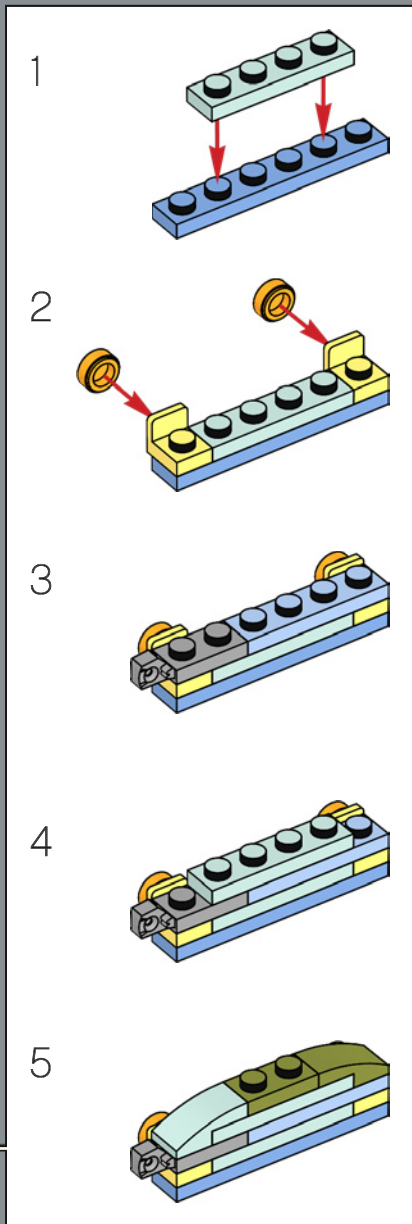
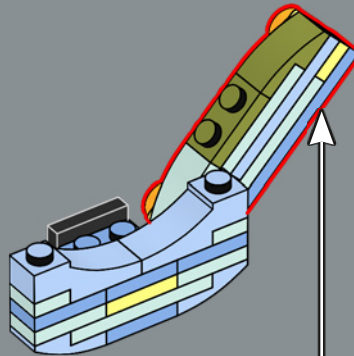

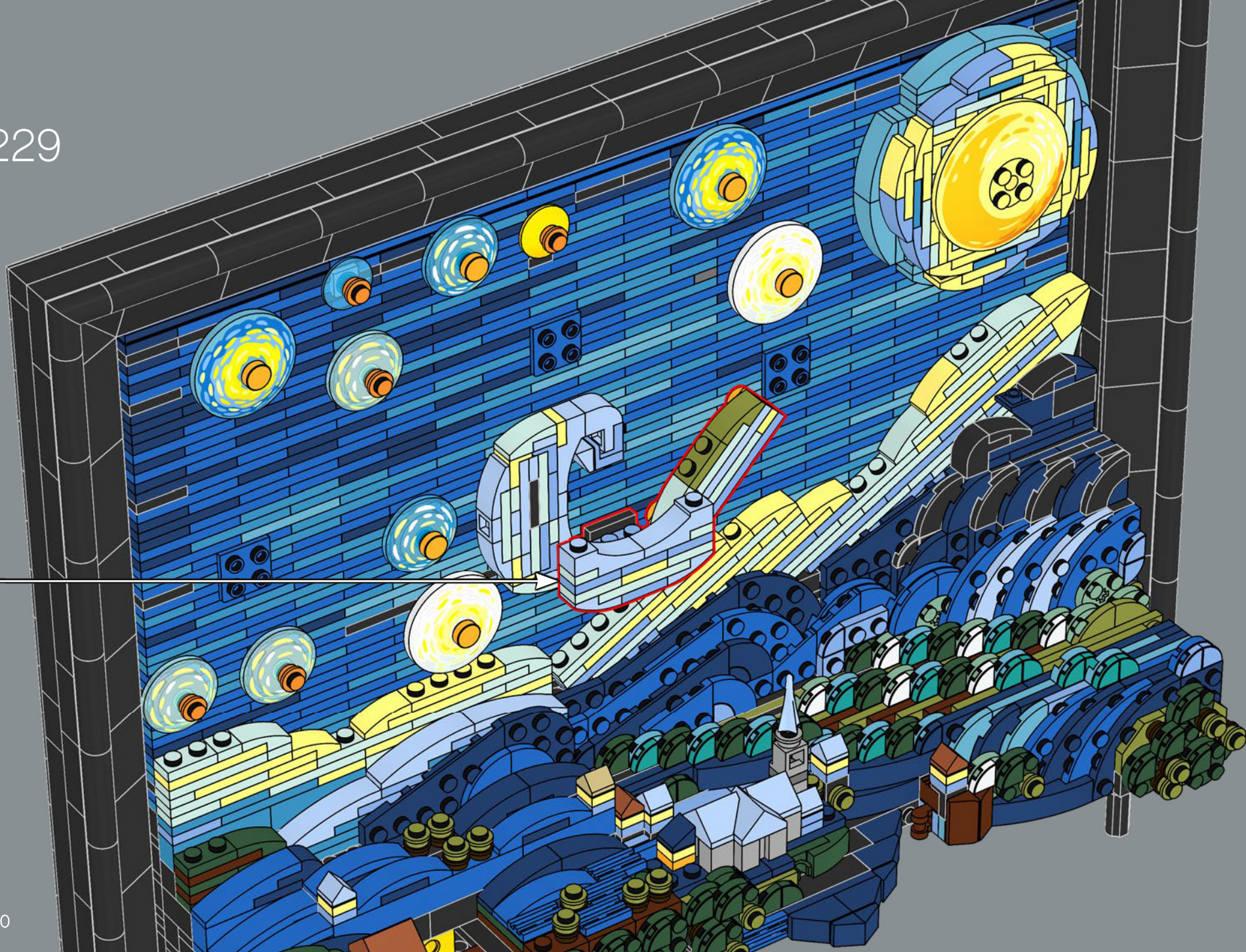

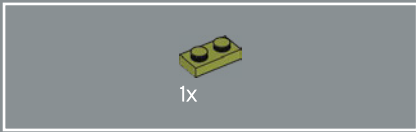
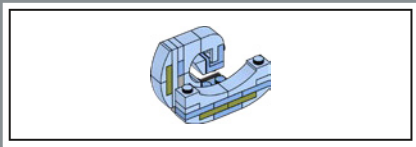

230

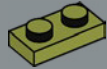

231

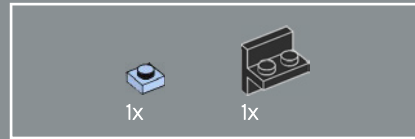
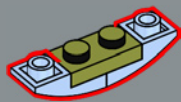

232

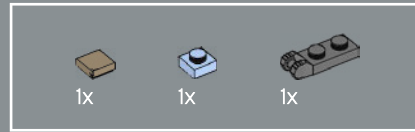
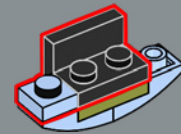

233

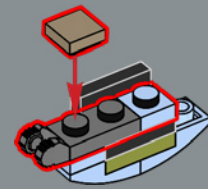

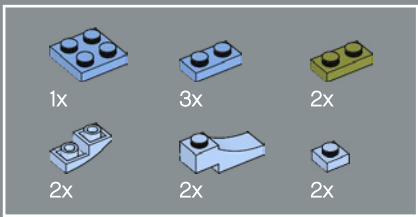

234

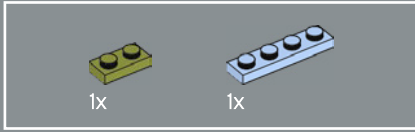
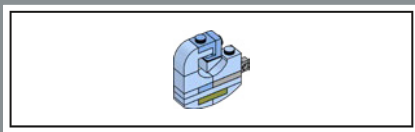
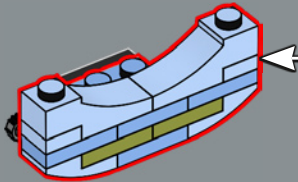
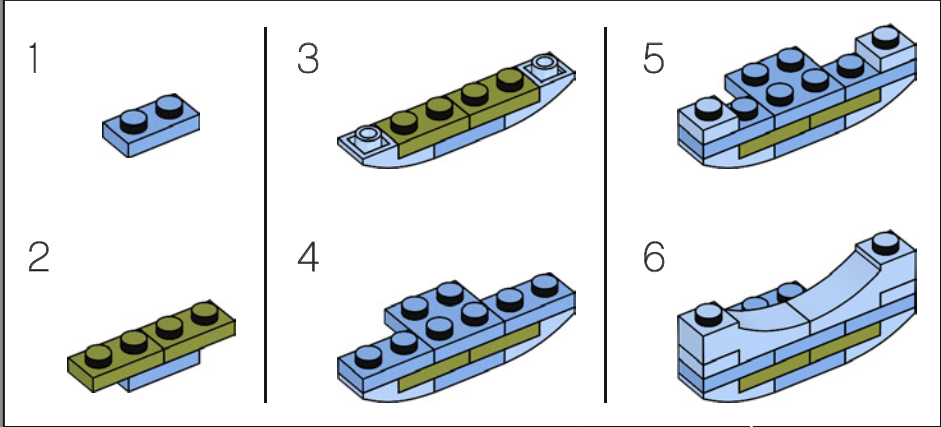

235

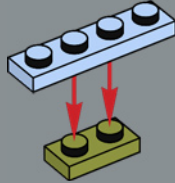

236

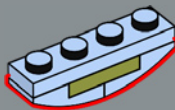

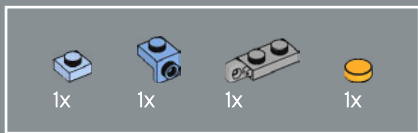

237

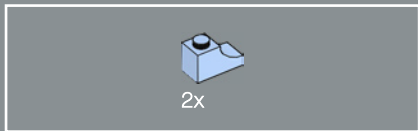
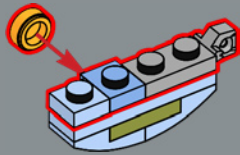

238

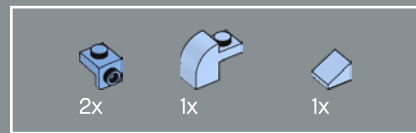
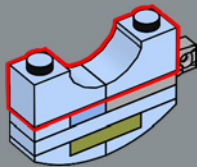

239

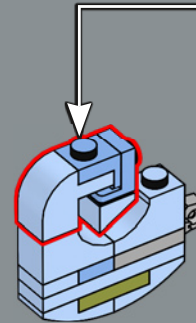
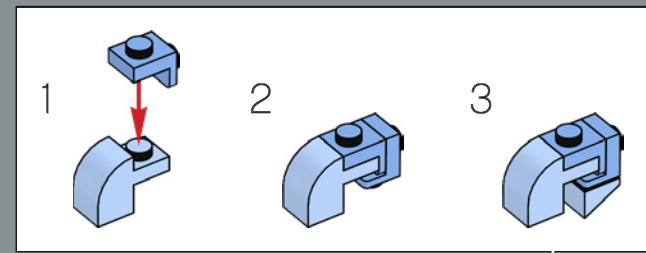

240

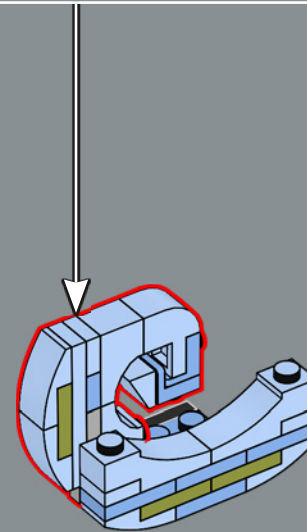

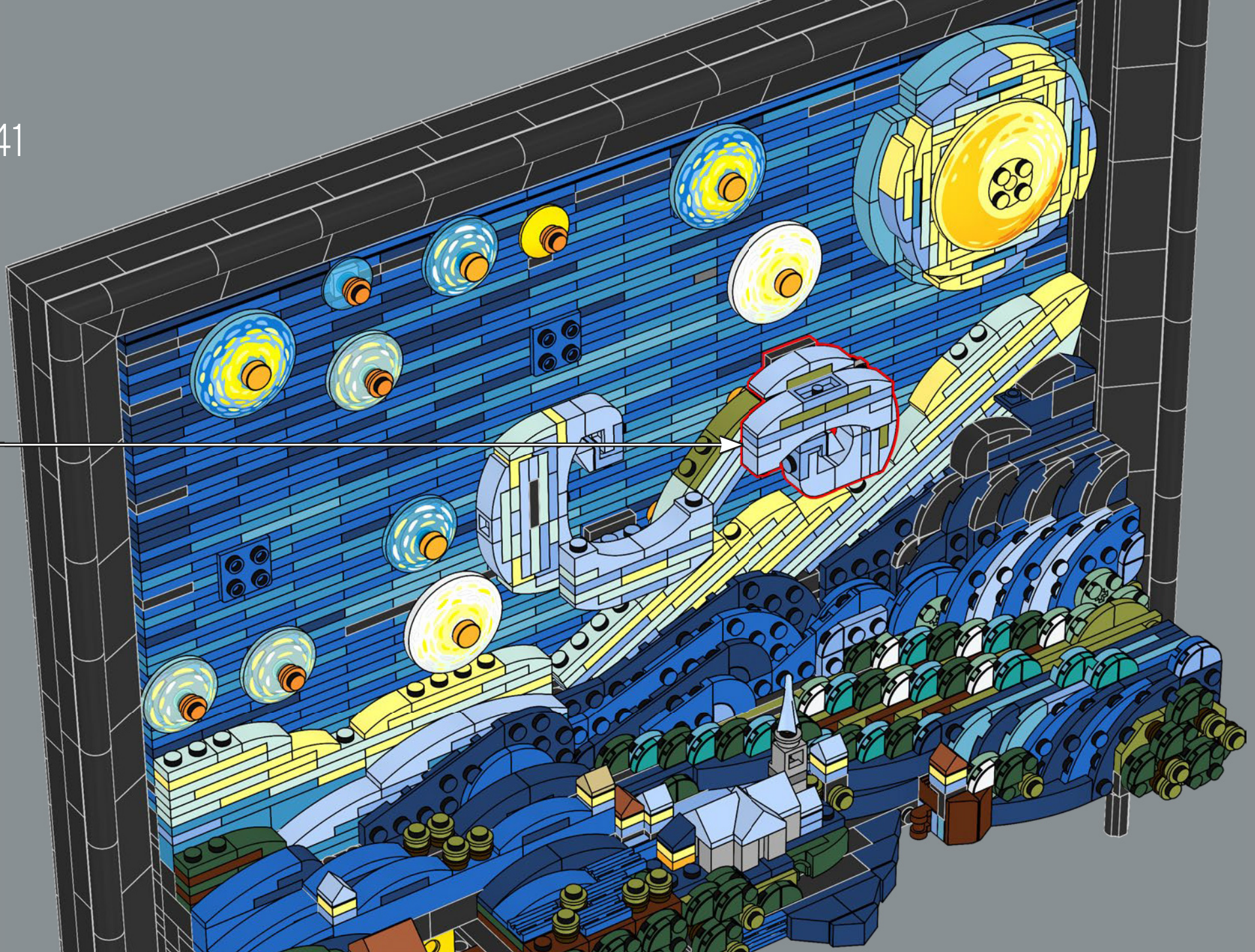

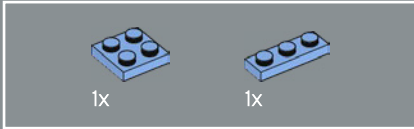
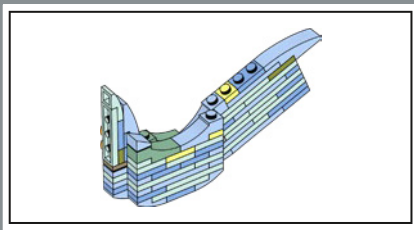

242

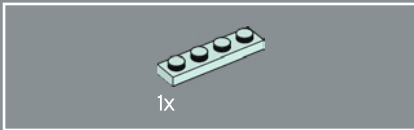
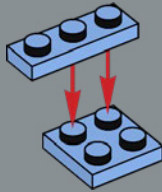

243

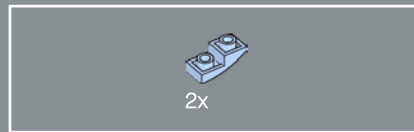
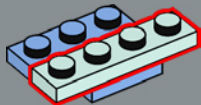

244

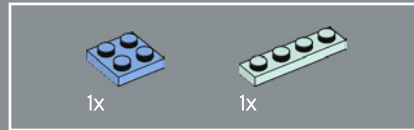
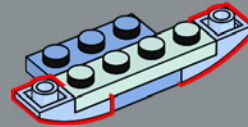

245

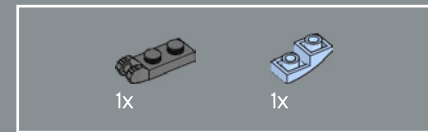
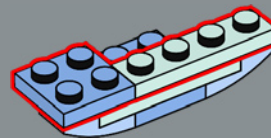

246

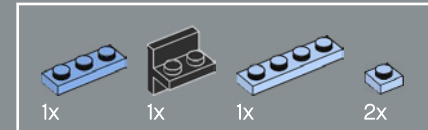
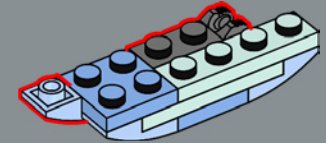

247

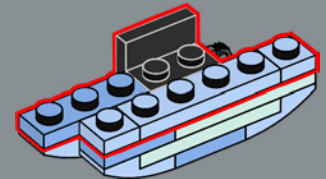

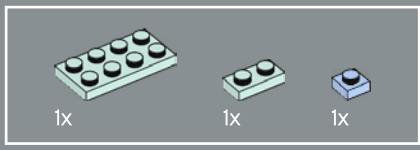

248

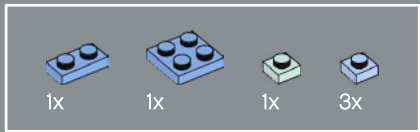
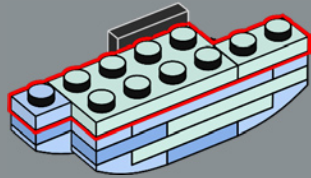

249

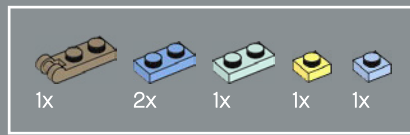
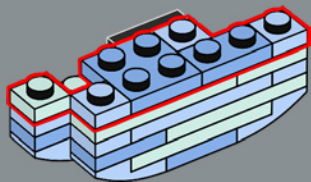

250

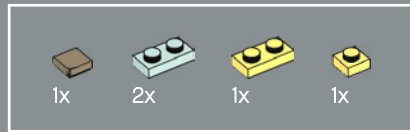
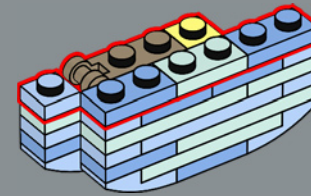

251

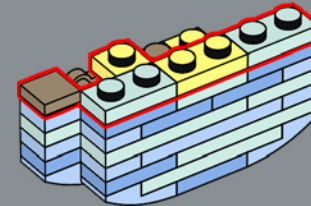



252

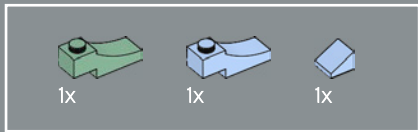
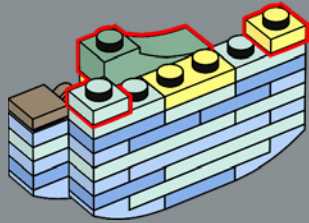

253

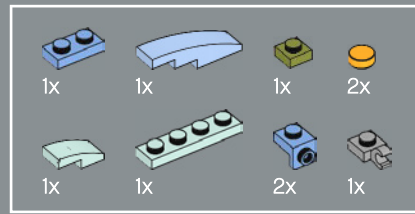
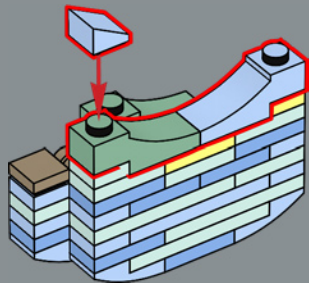

254

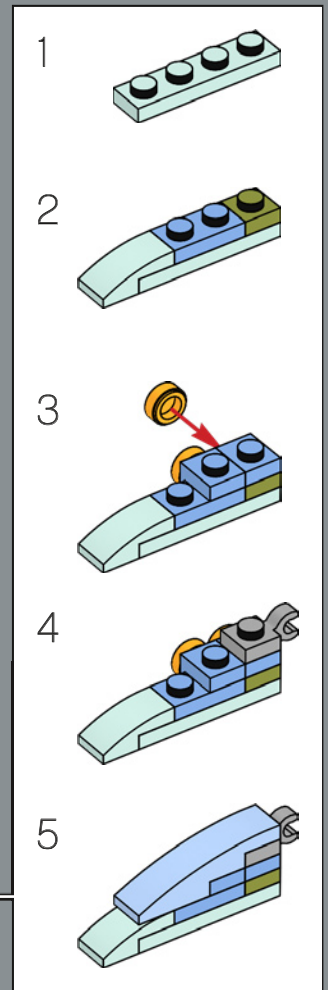
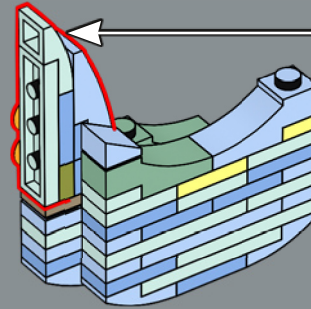

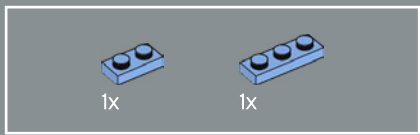

255

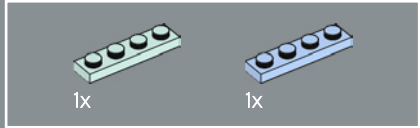
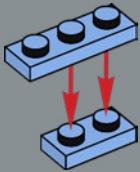

256

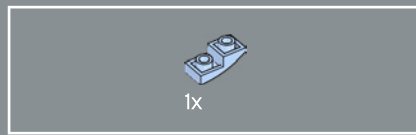
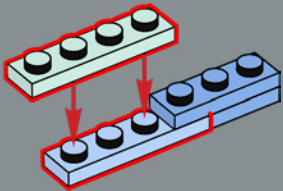

257

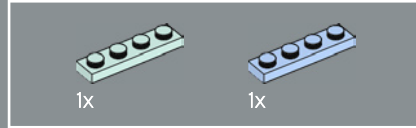
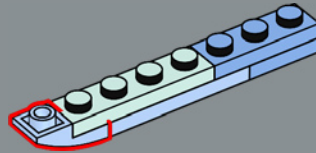

258

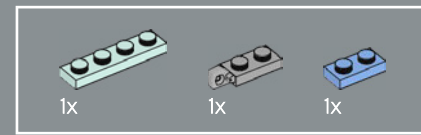
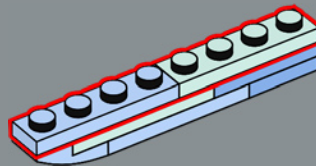

259

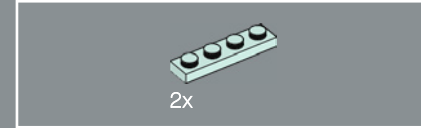
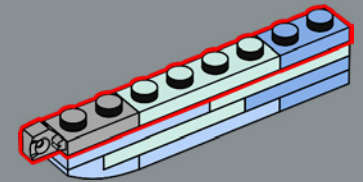

260

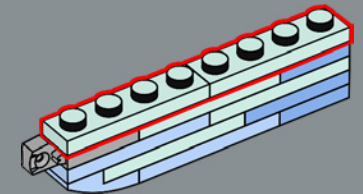

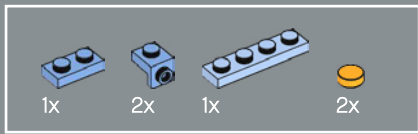

261

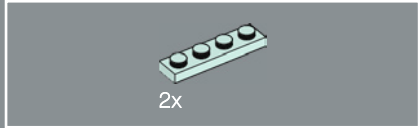
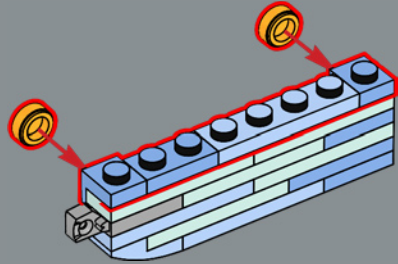

262

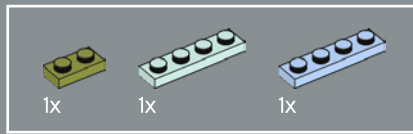
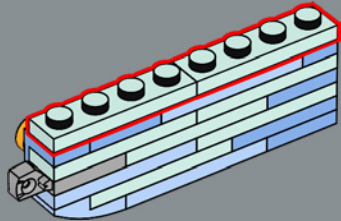

263

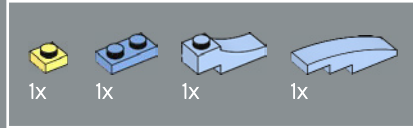
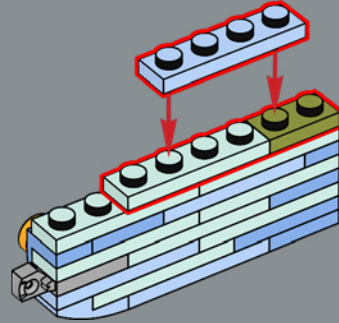

264

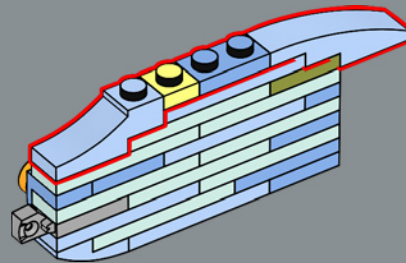

265

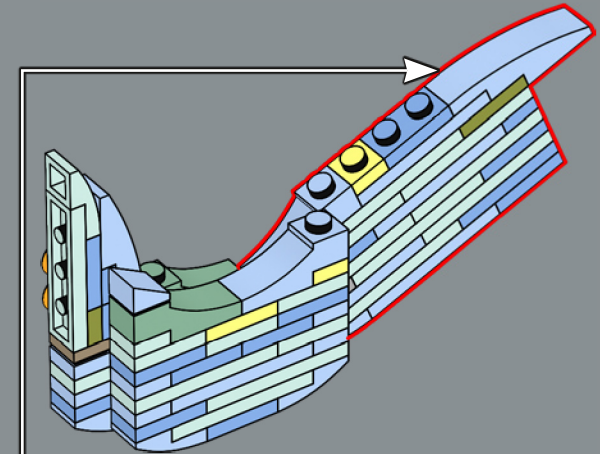

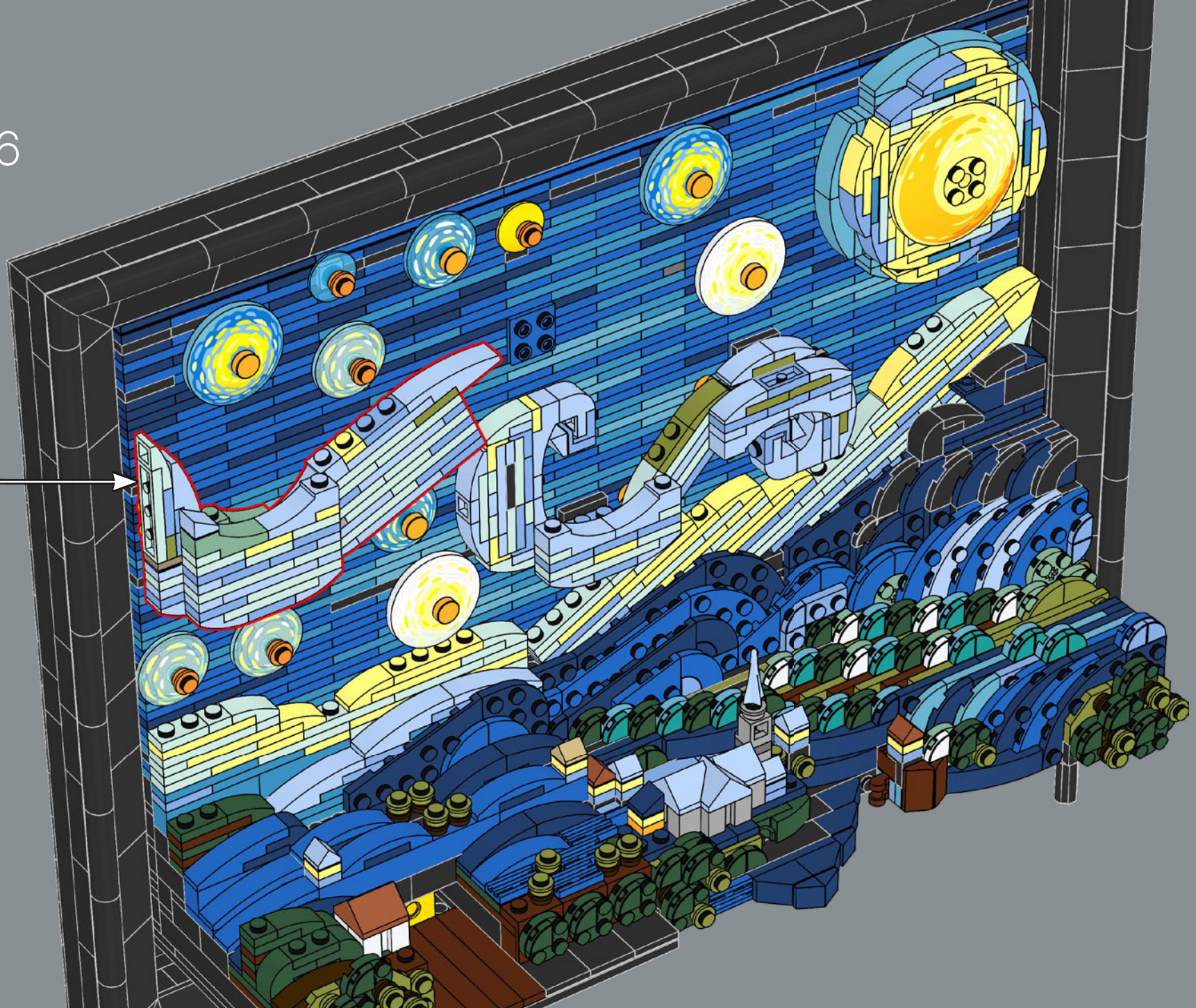

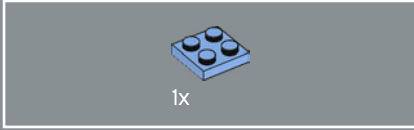
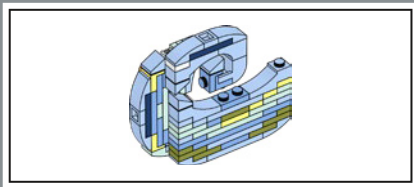

1x

267

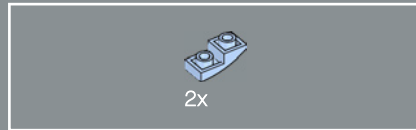
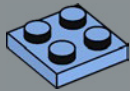

2x

268

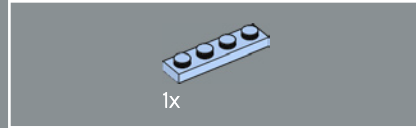
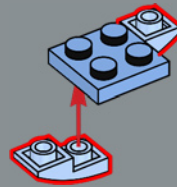

1x

269

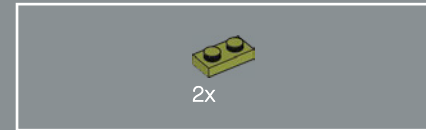
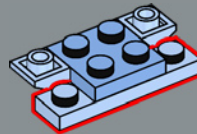

2x

270

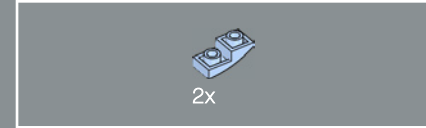
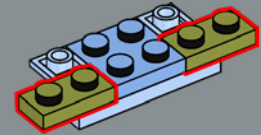

2x

271

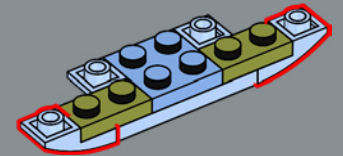

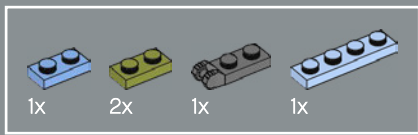

272

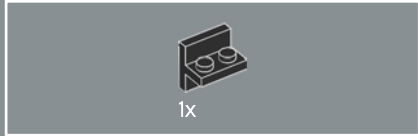
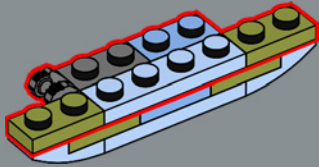

273

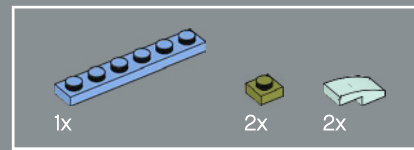
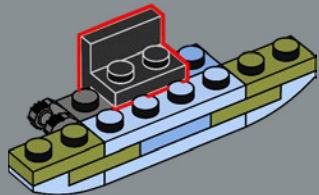

274

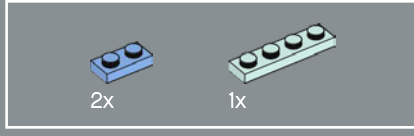
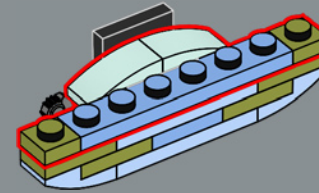

275

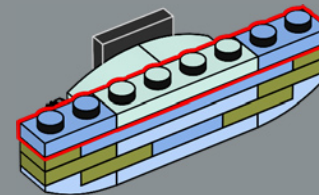



276

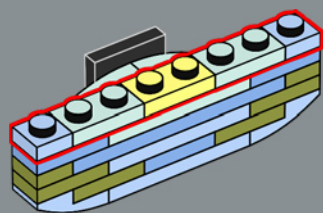

277

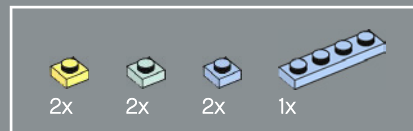
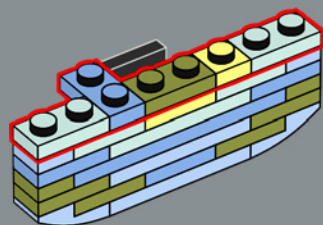

278

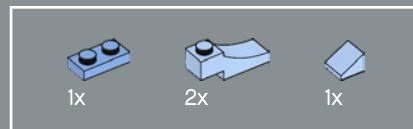
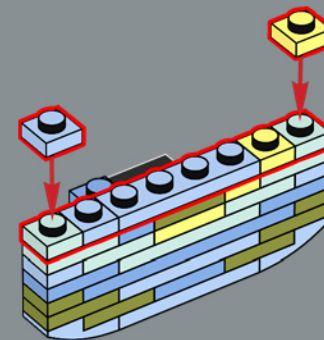

279

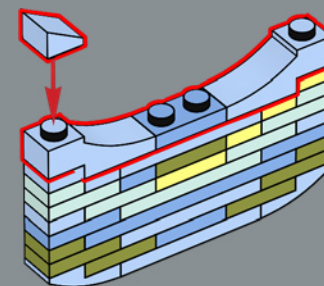

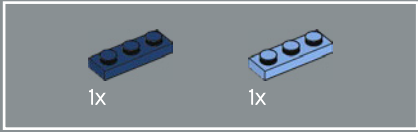
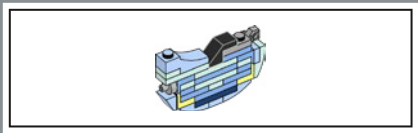

280

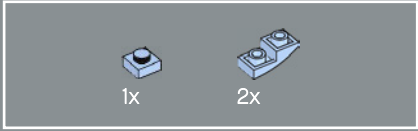
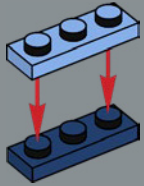

281

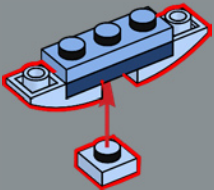

282

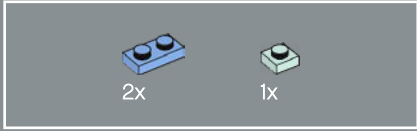
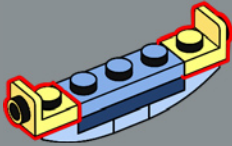

283

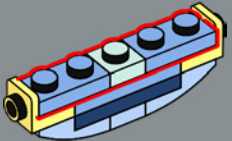

284

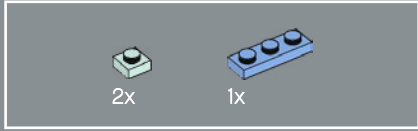
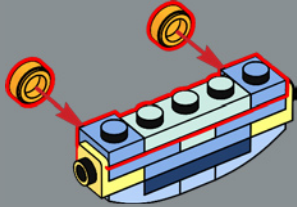

285

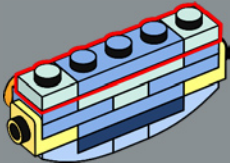

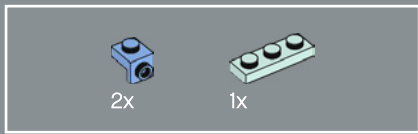

286

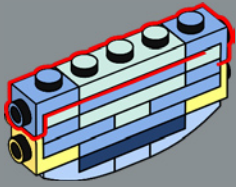

287

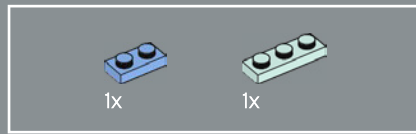
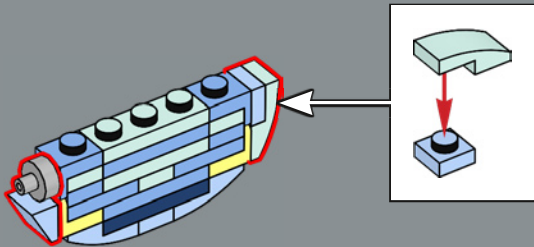

288

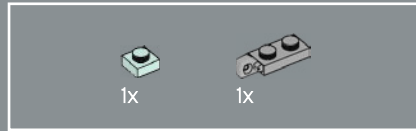
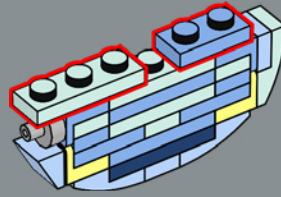

289

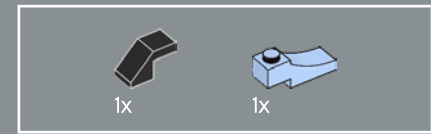
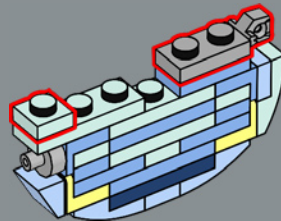

290

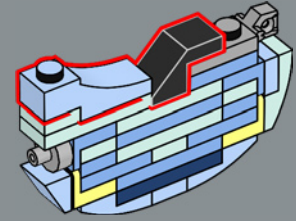

291

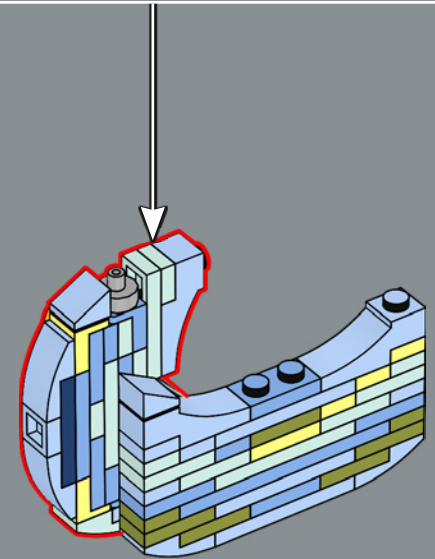

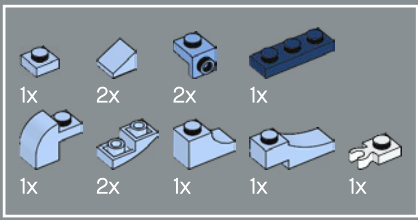

292

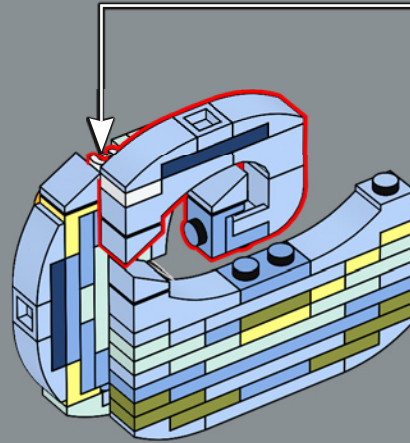
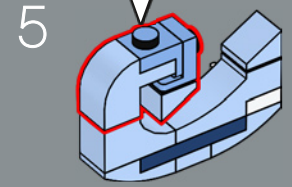
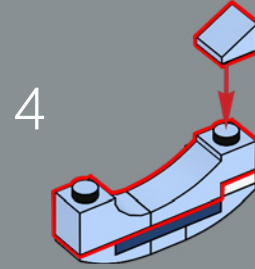
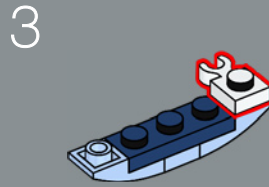
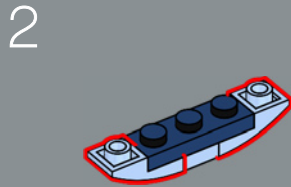
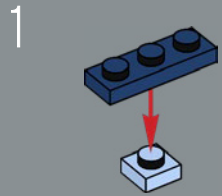
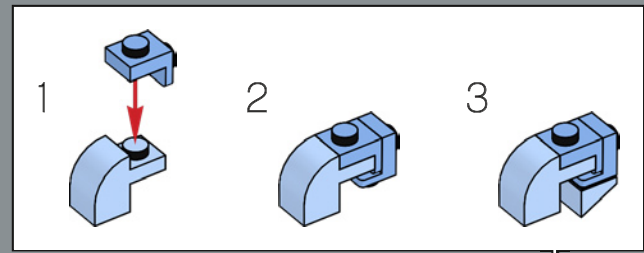

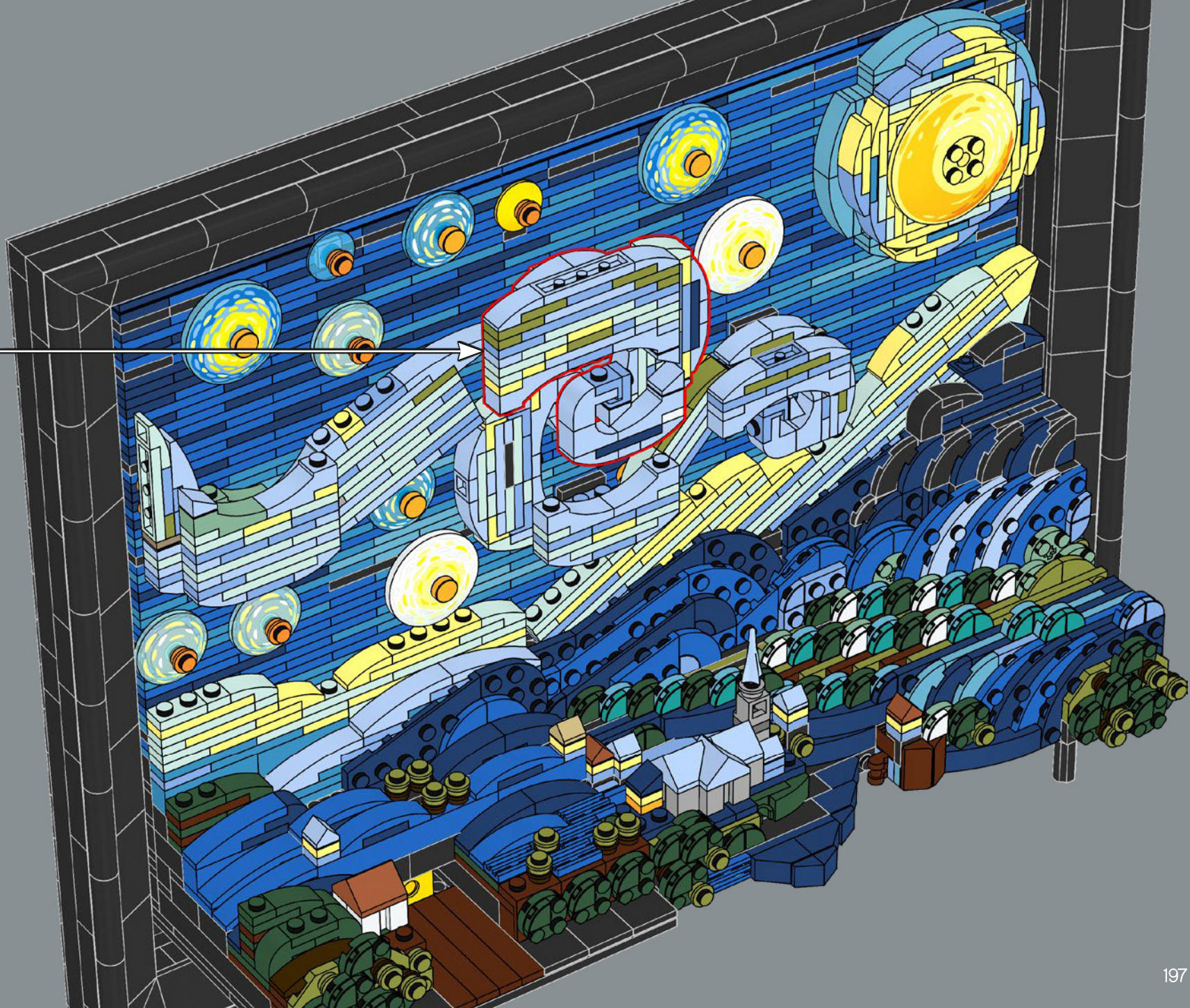

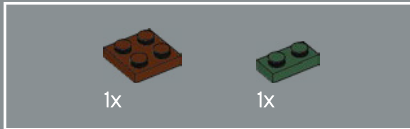
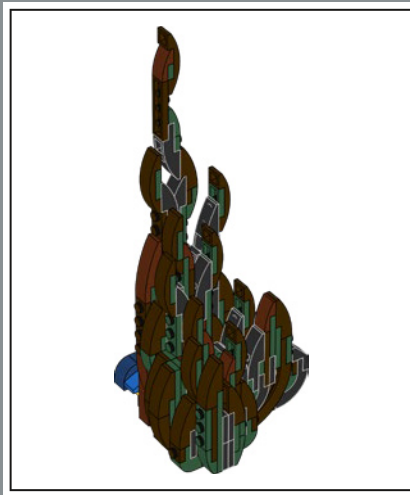

294

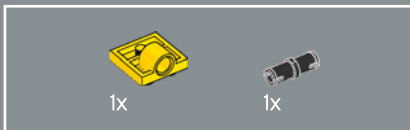

295

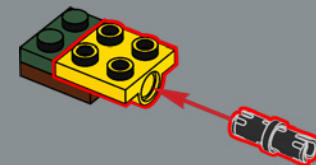
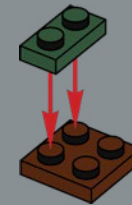

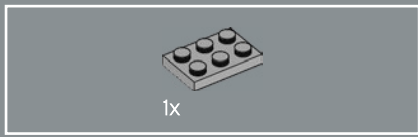

296

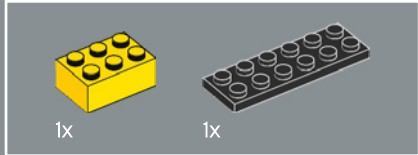

297

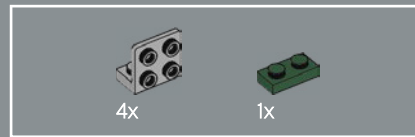
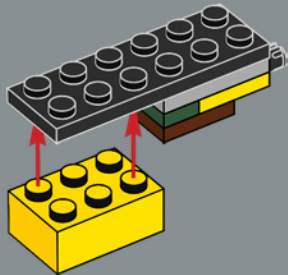

298

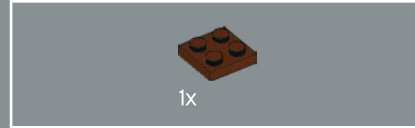
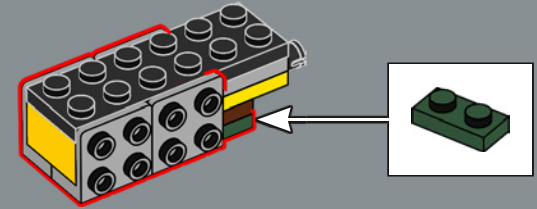

299

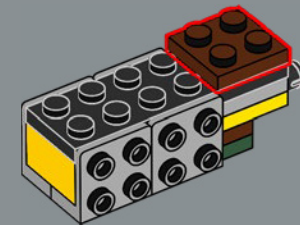



2x

300

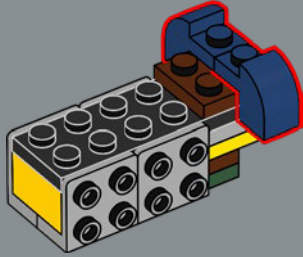

1x



1x

301

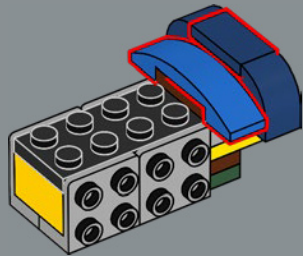

4x

302

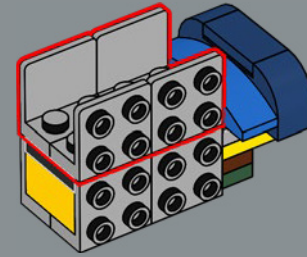

1x



1x

303

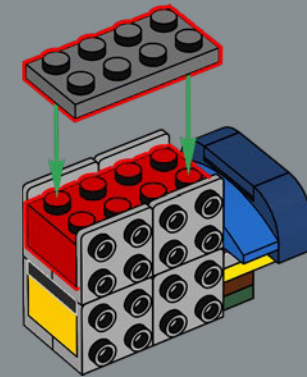

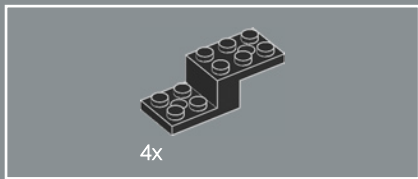

304

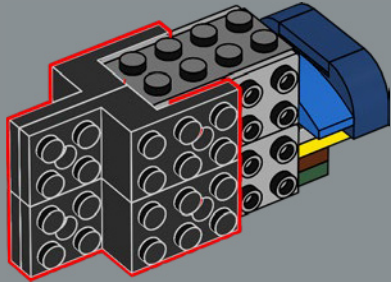

305

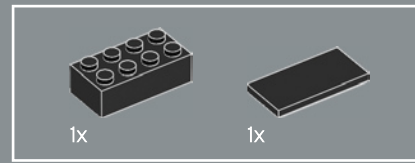
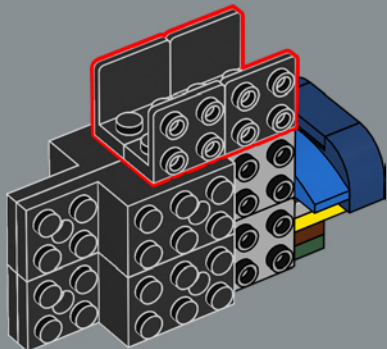

306

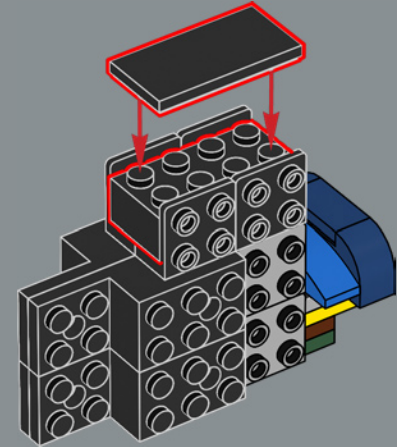

307

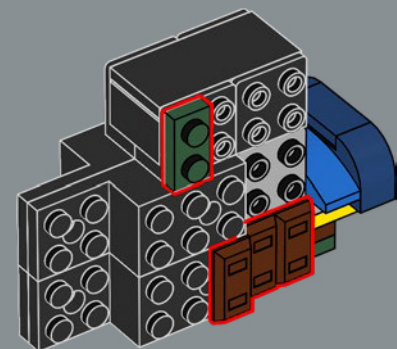

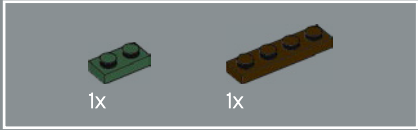
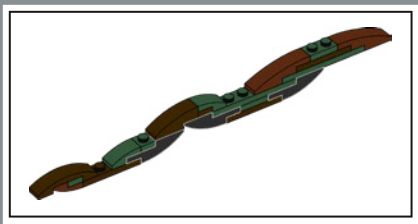

308

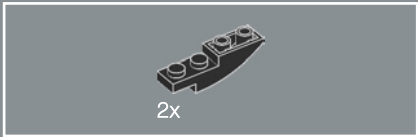
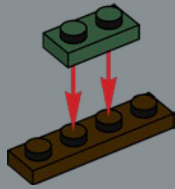

309

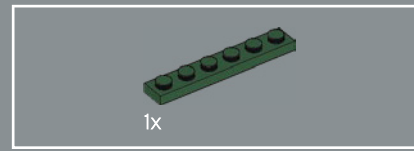
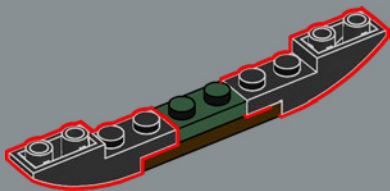

310

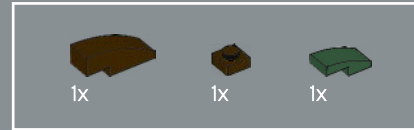
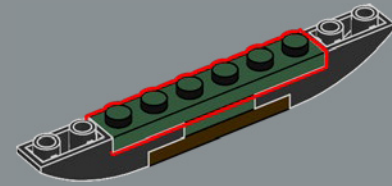

311

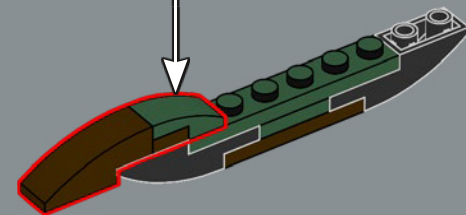
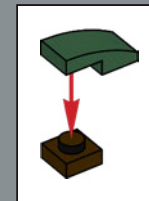

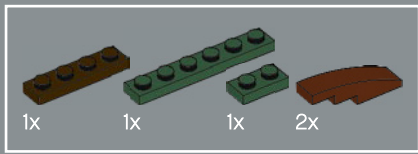

312

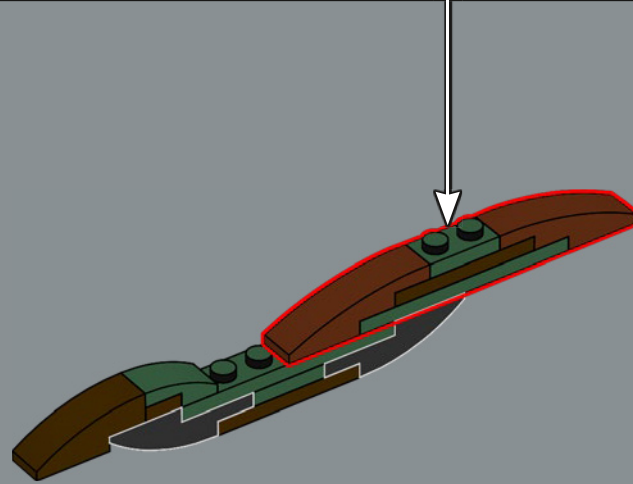
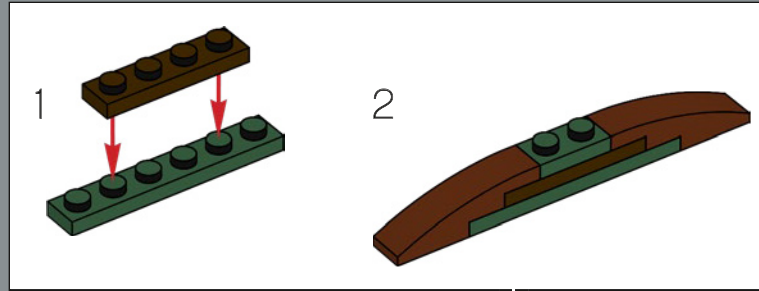

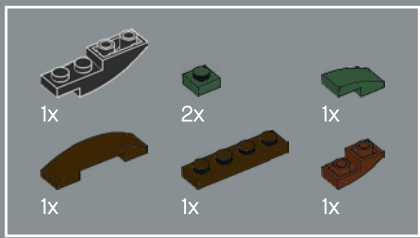

313

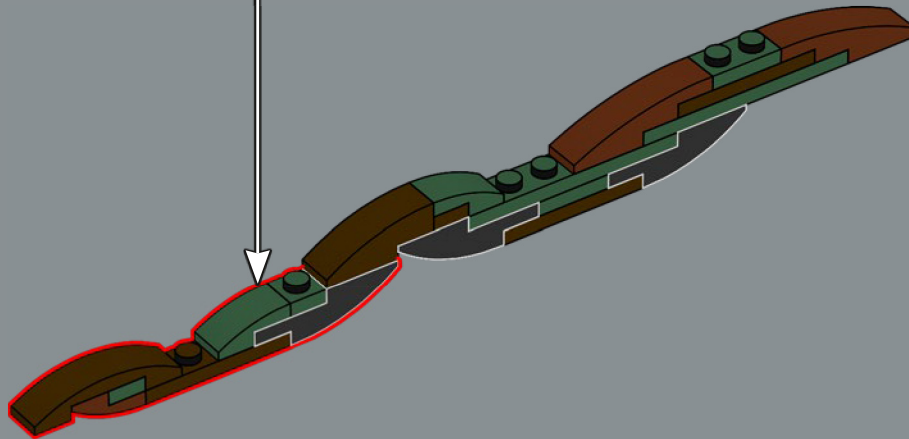
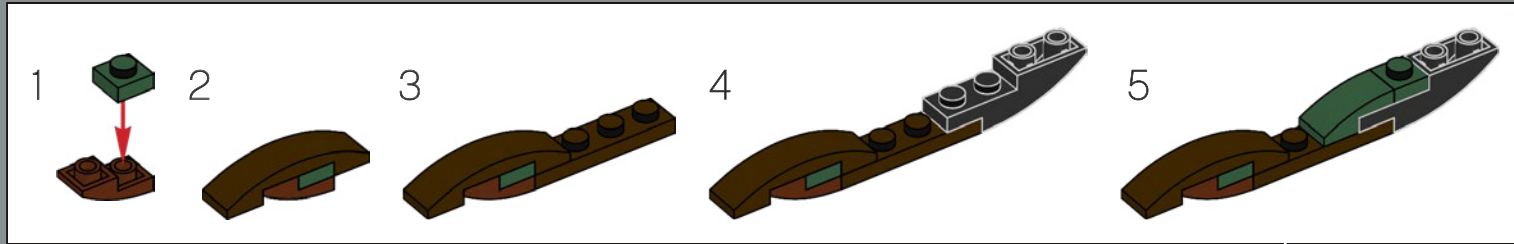

314

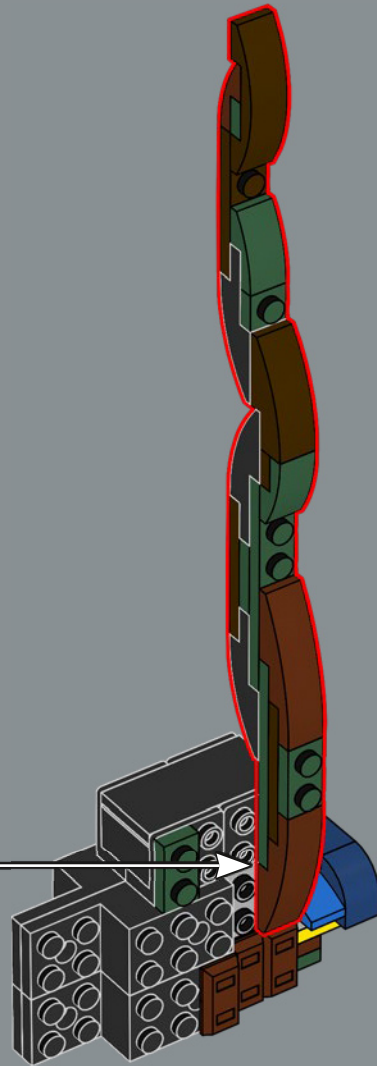

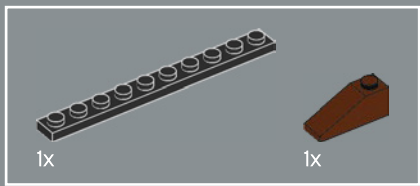

315

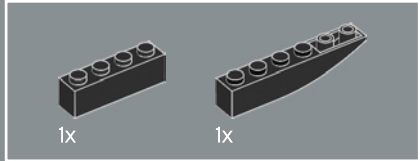
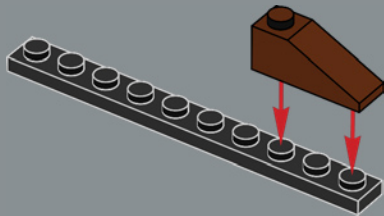

316

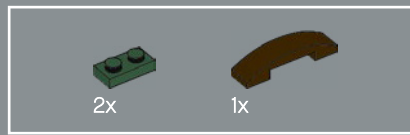
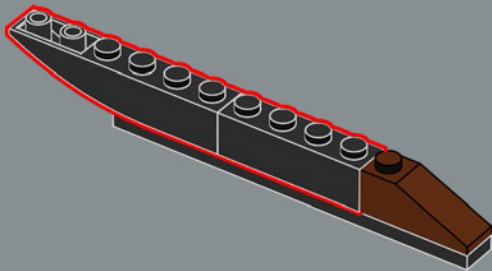

317

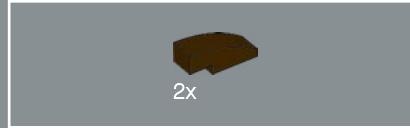
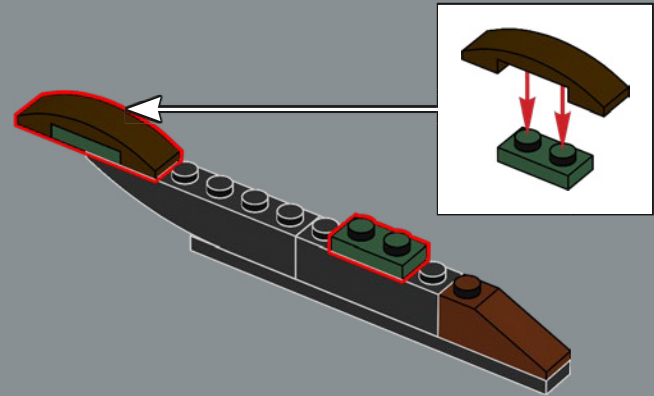

318

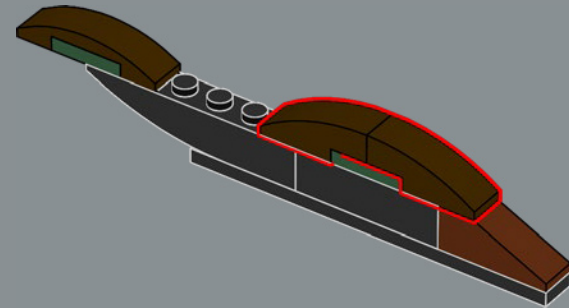

319

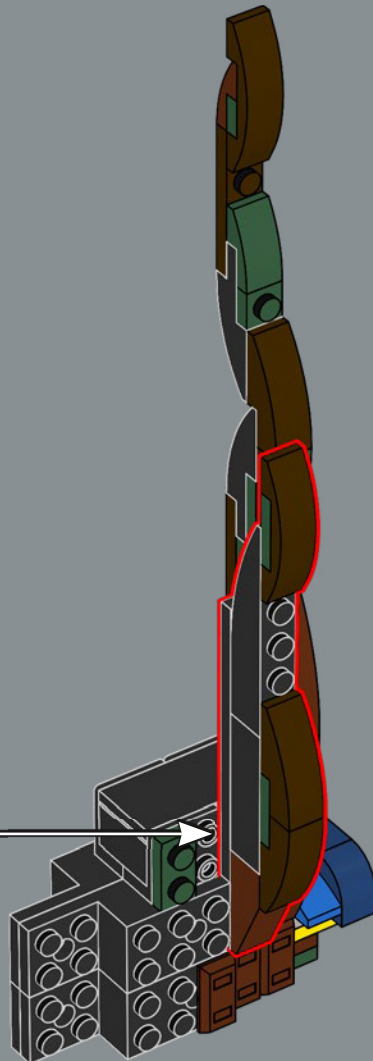



320

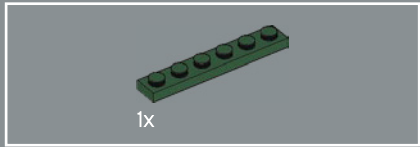
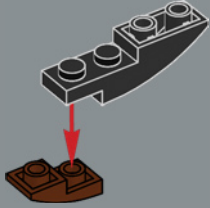

321

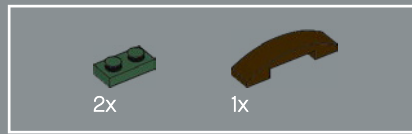
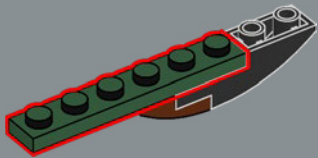

322

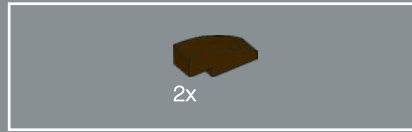
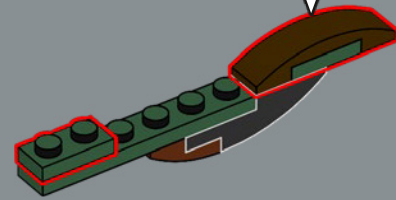
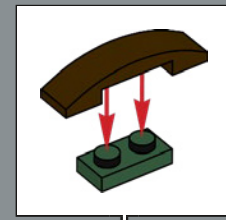

323

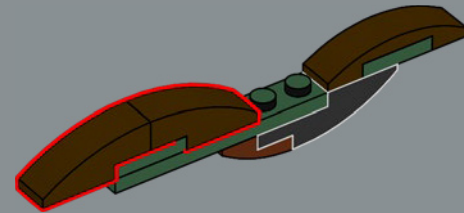

324

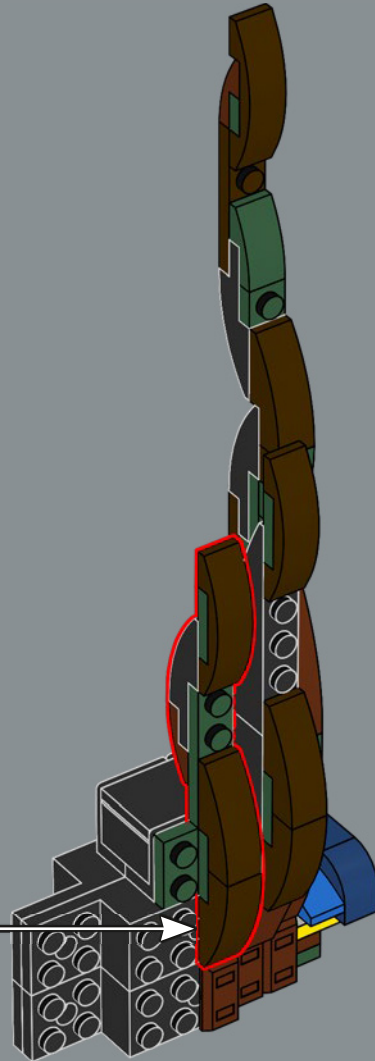

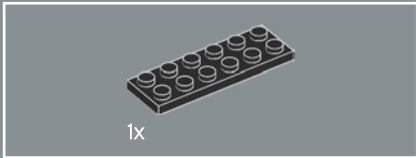
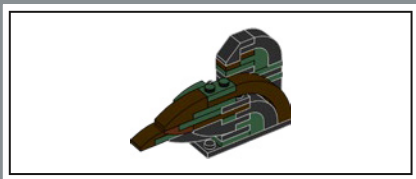

325

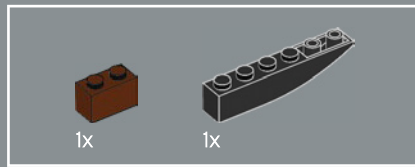
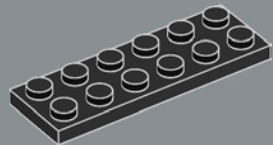

326

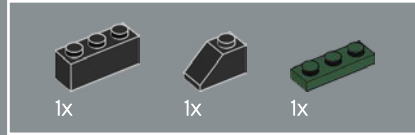
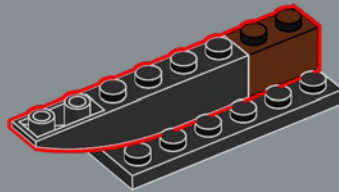

327

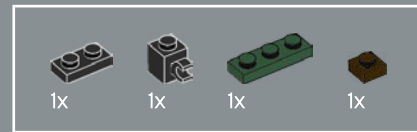
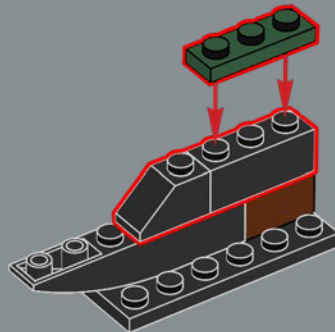

328

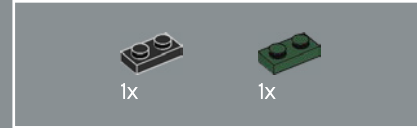
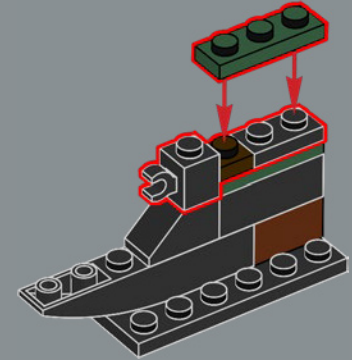

329

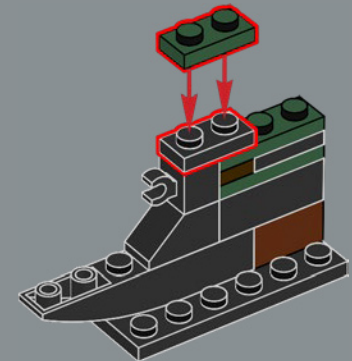



330

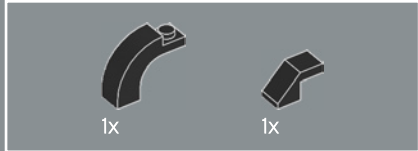
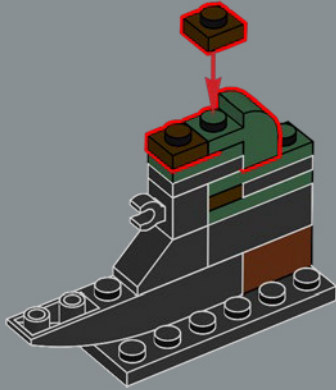

331

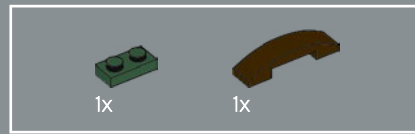
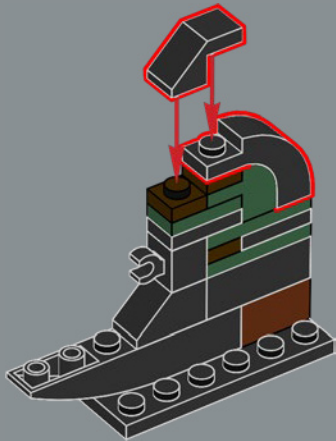

332

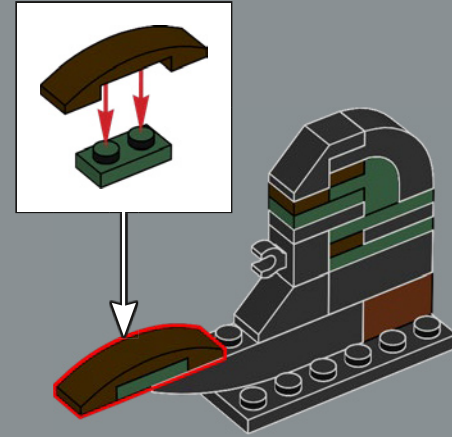

333

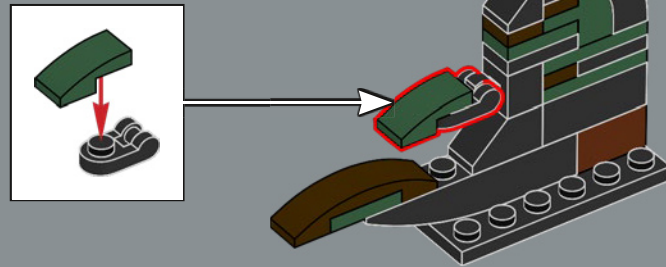

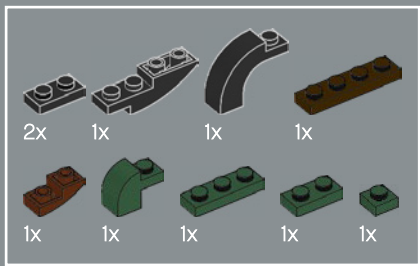

334

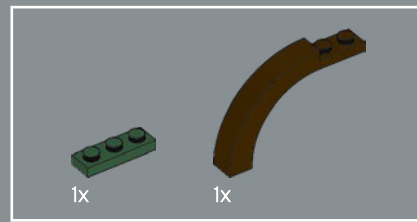
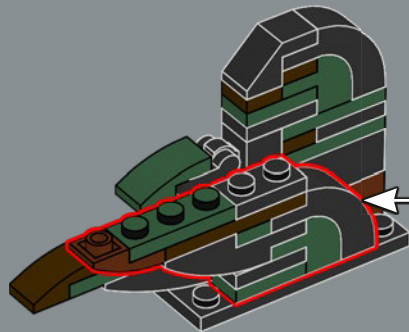
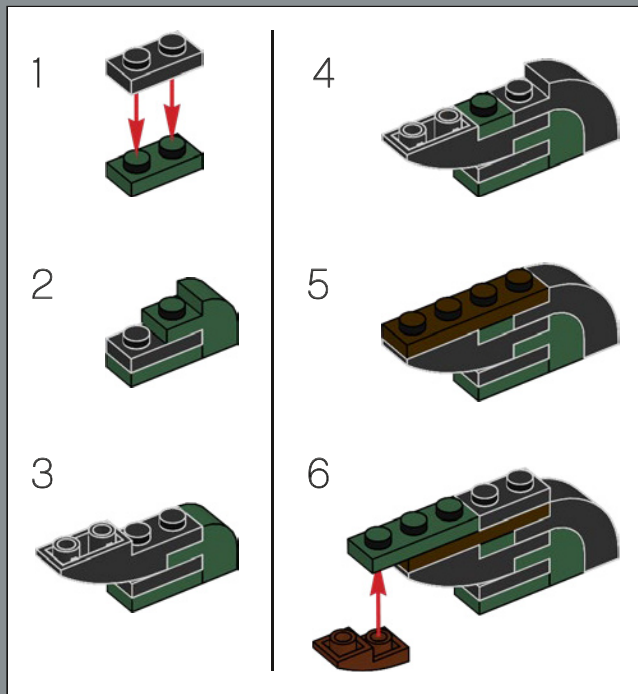

335

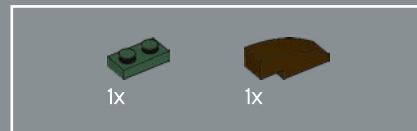
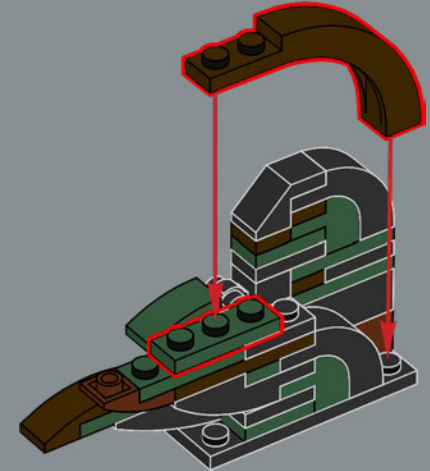

336

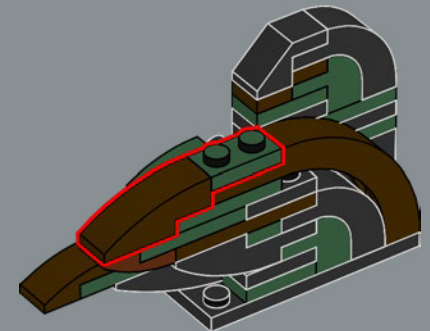

337

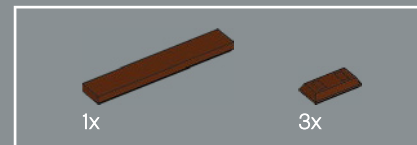
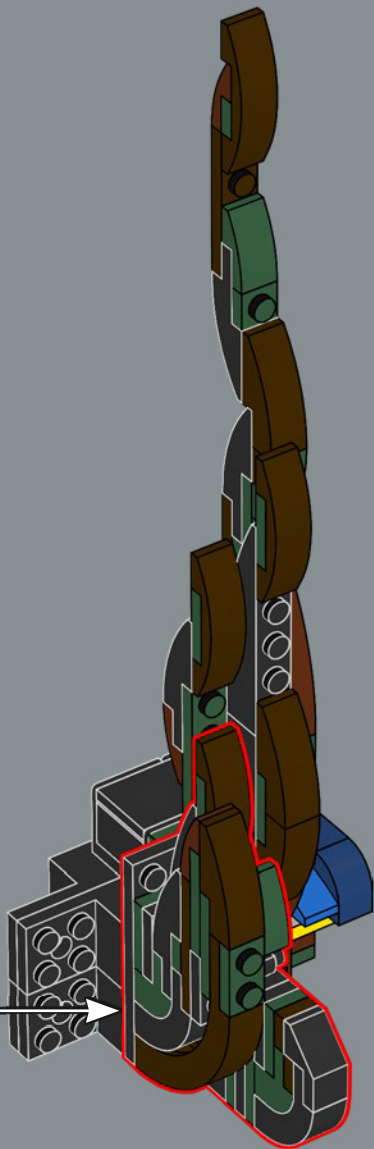

338

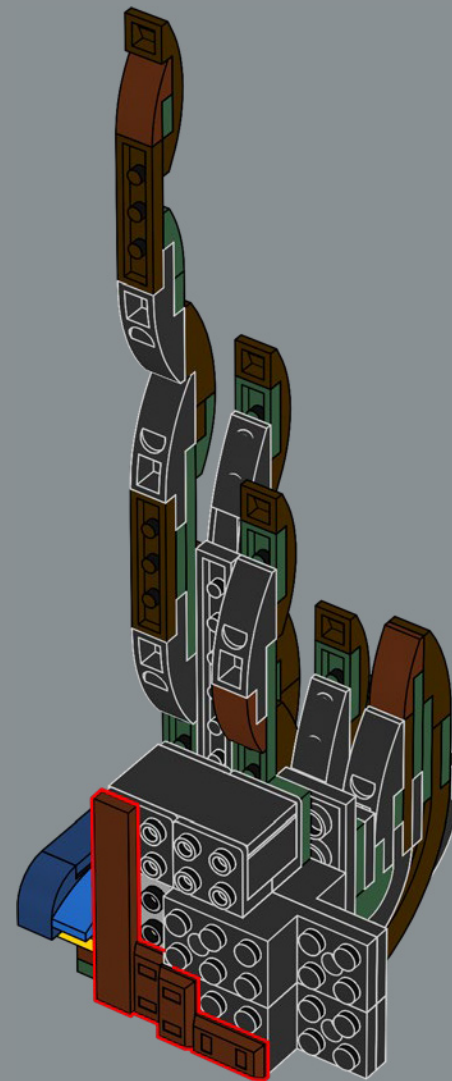

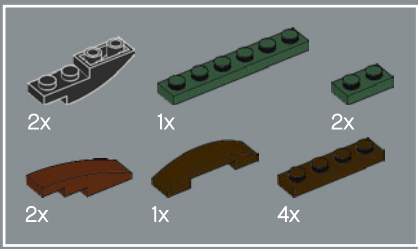

339

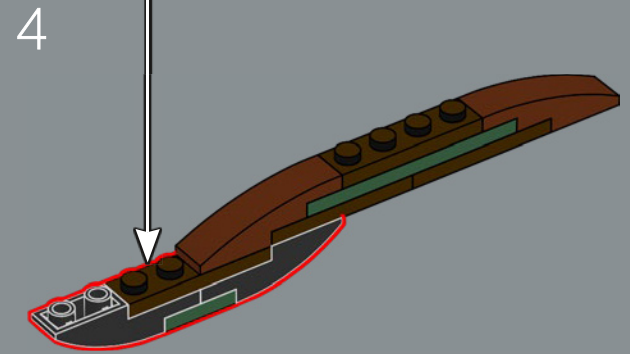
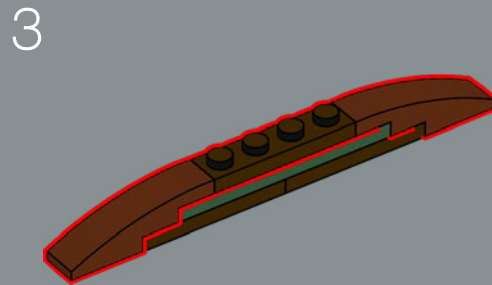
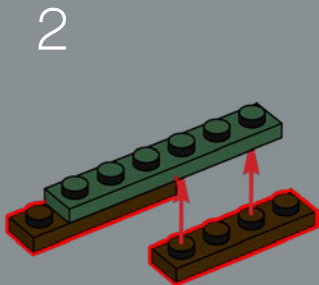
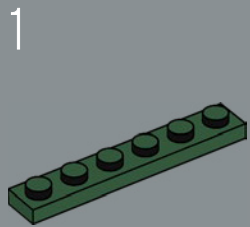
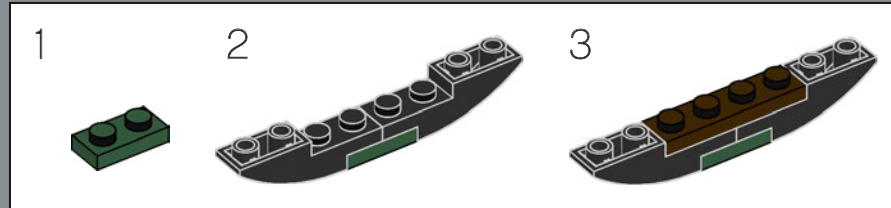

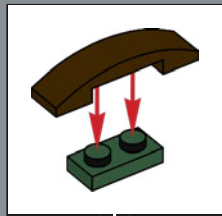

5

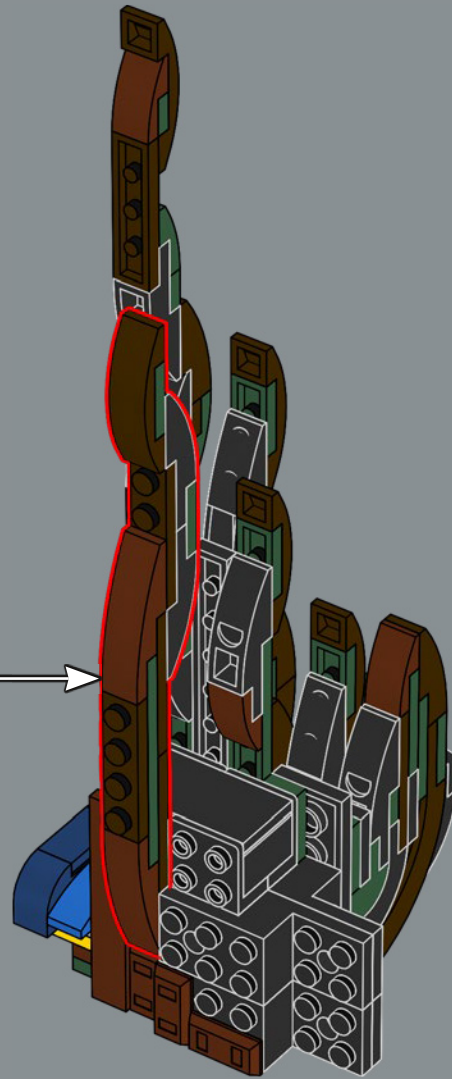
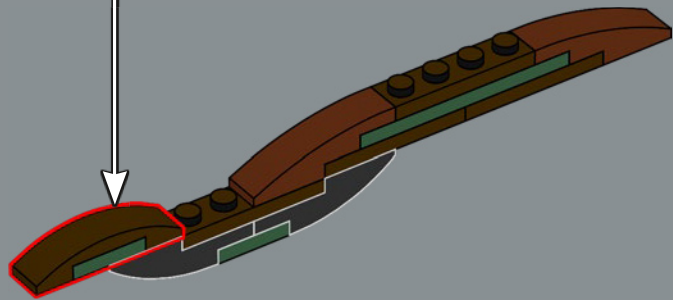

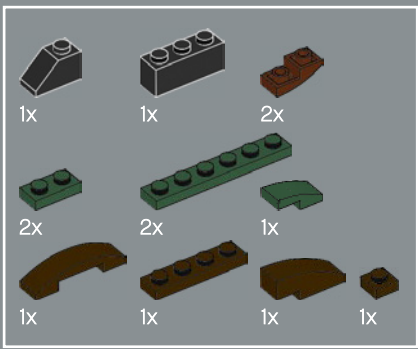

340

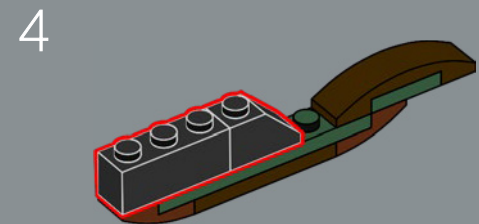
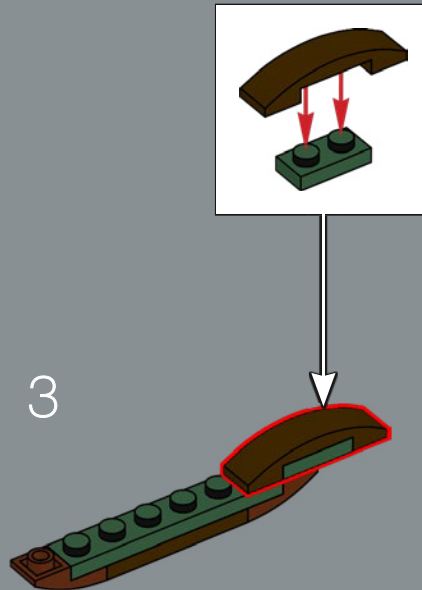
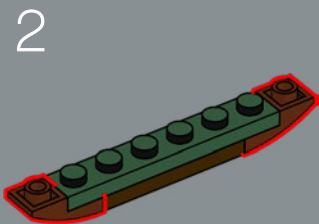
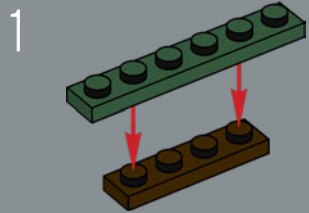

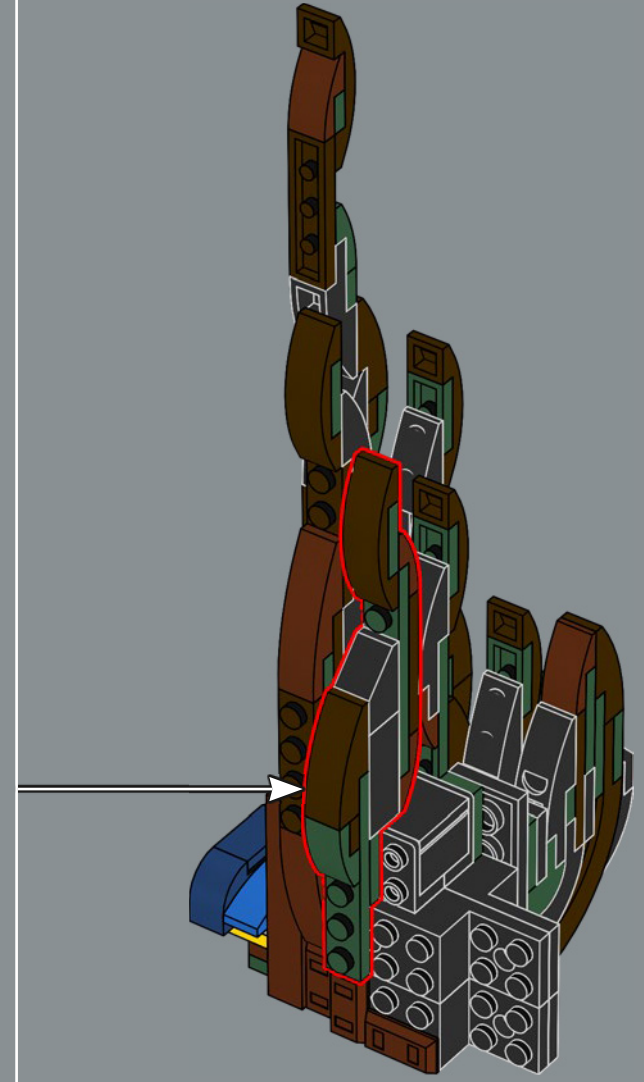
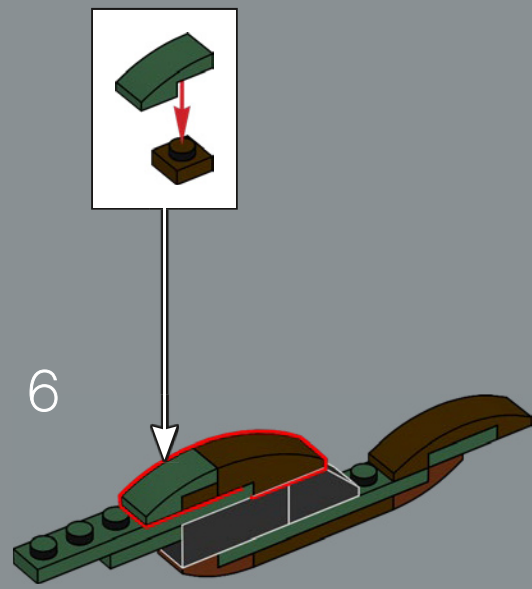
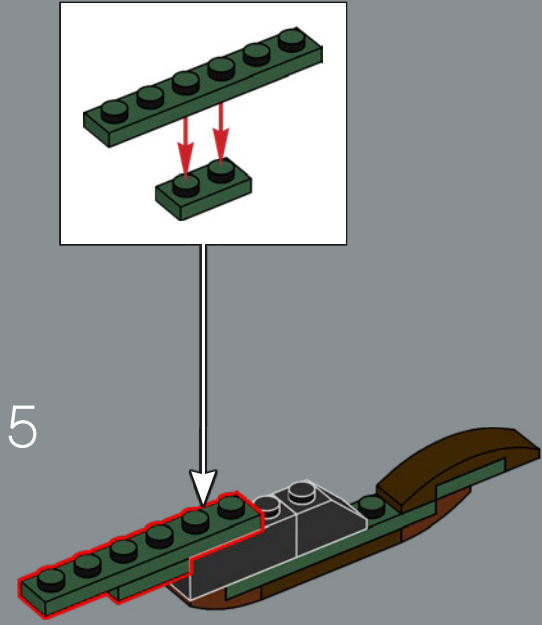

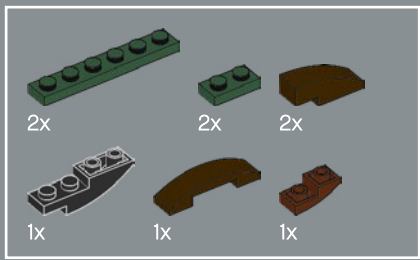

341

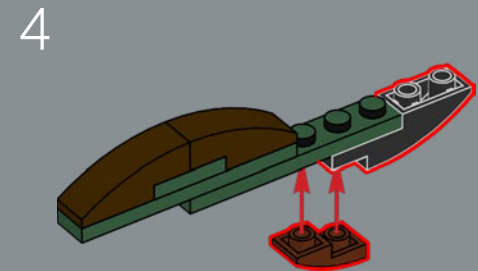
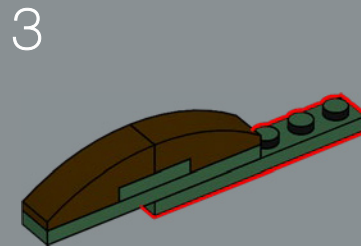
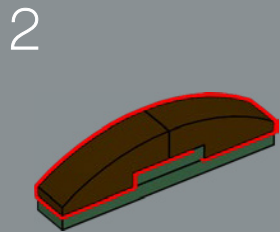
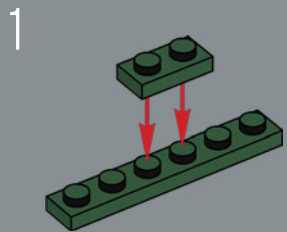

5

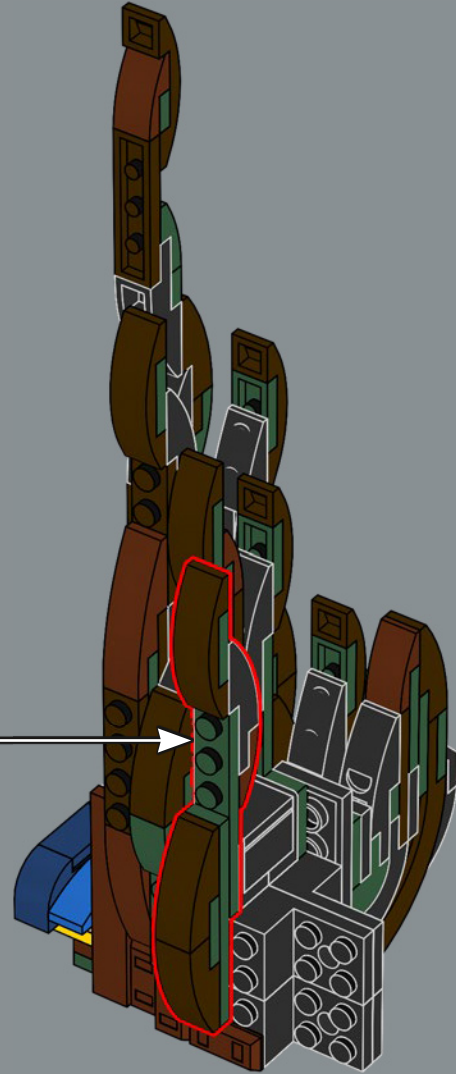
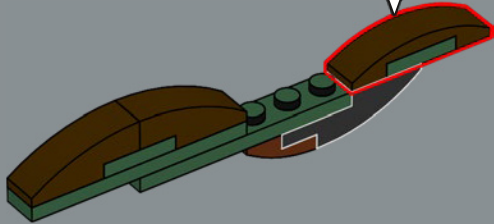
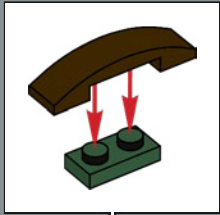

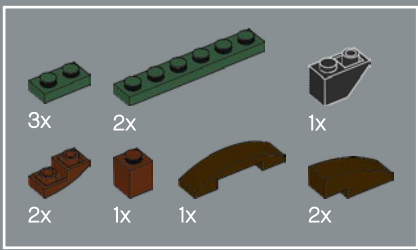

342

1

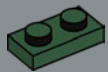

2

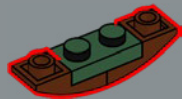

3

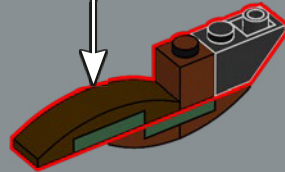
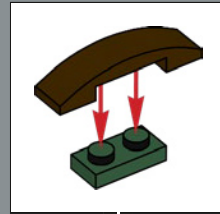

4

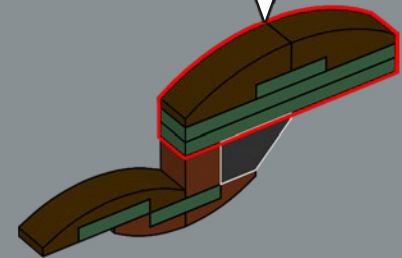
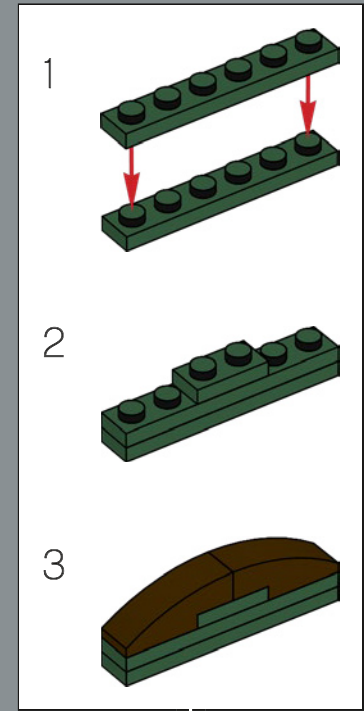

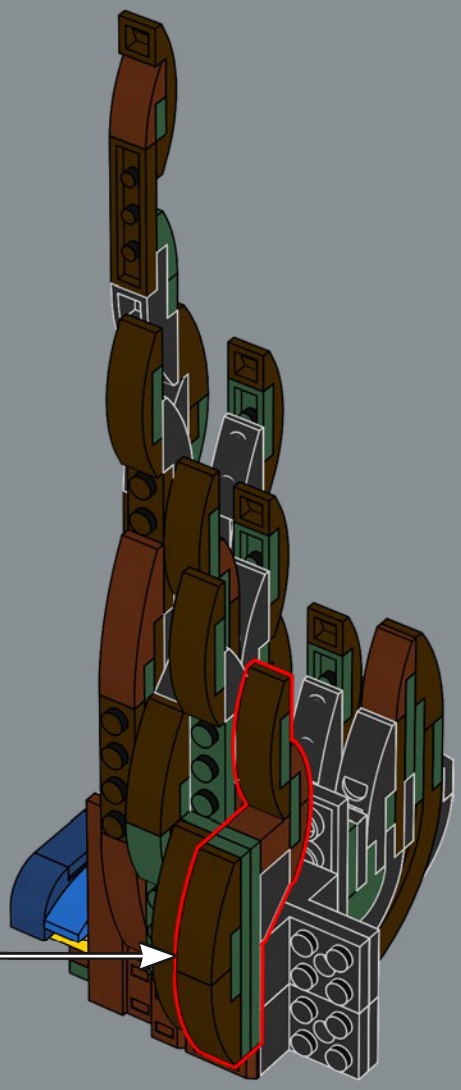

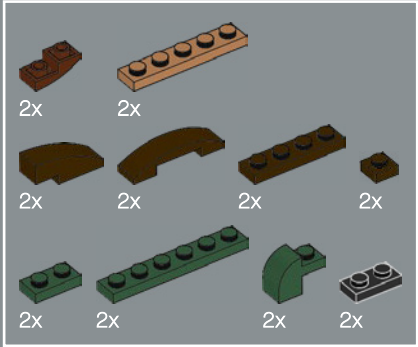
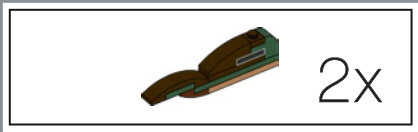

343

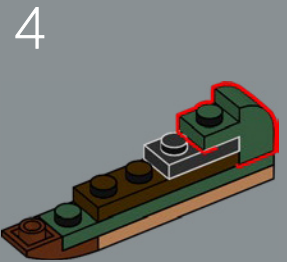
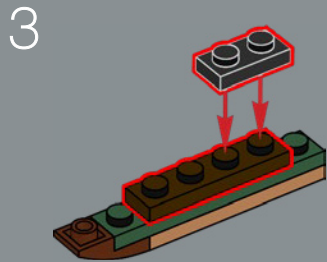
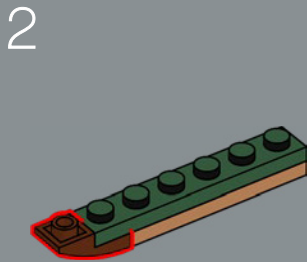
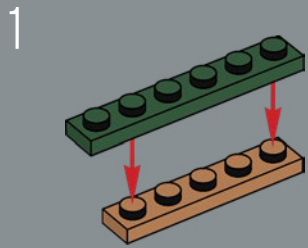

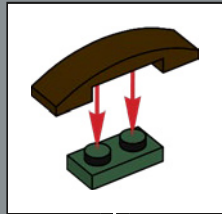

5

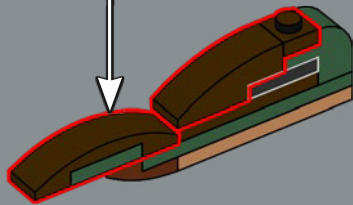

2x

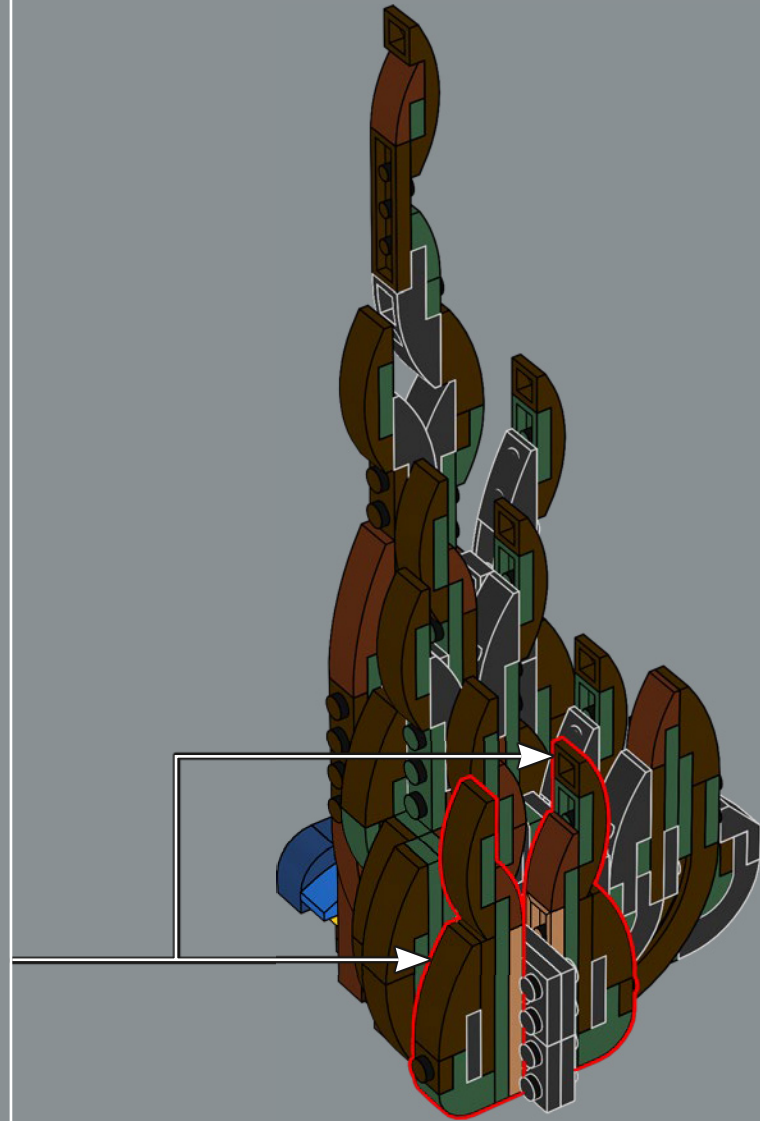

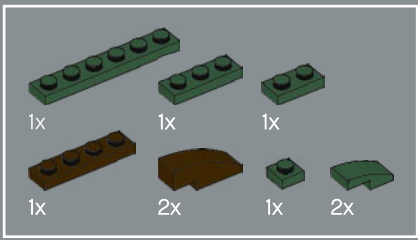

344

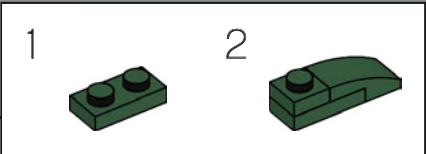
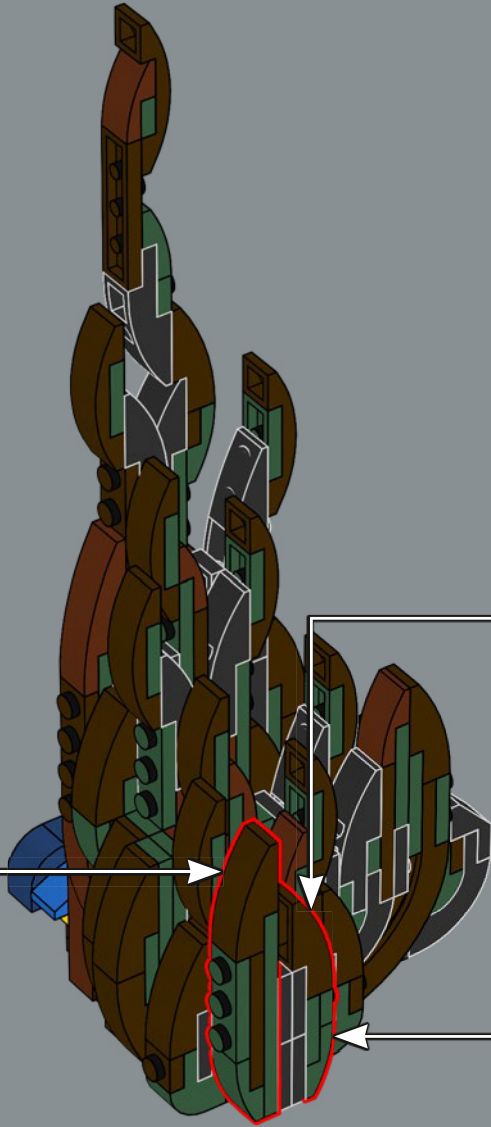
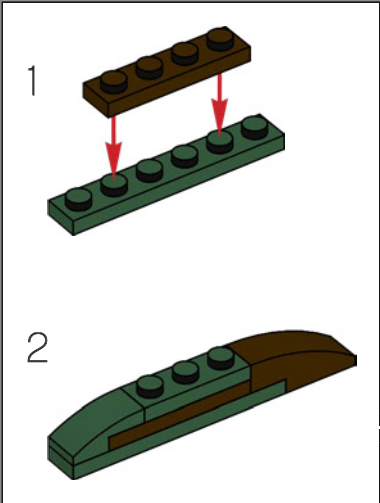

345

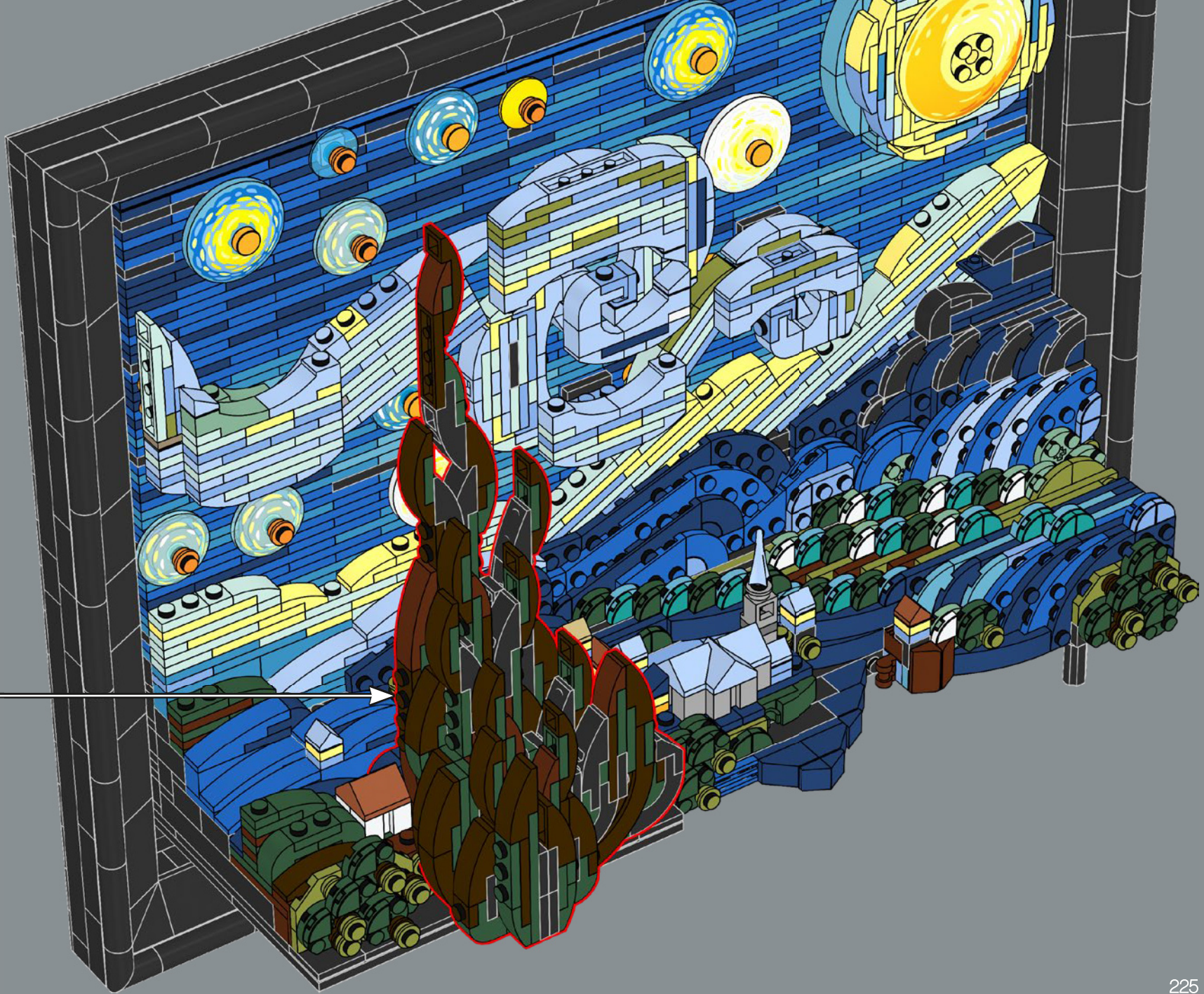

1x	1x	2x
2x	1x	2x

346

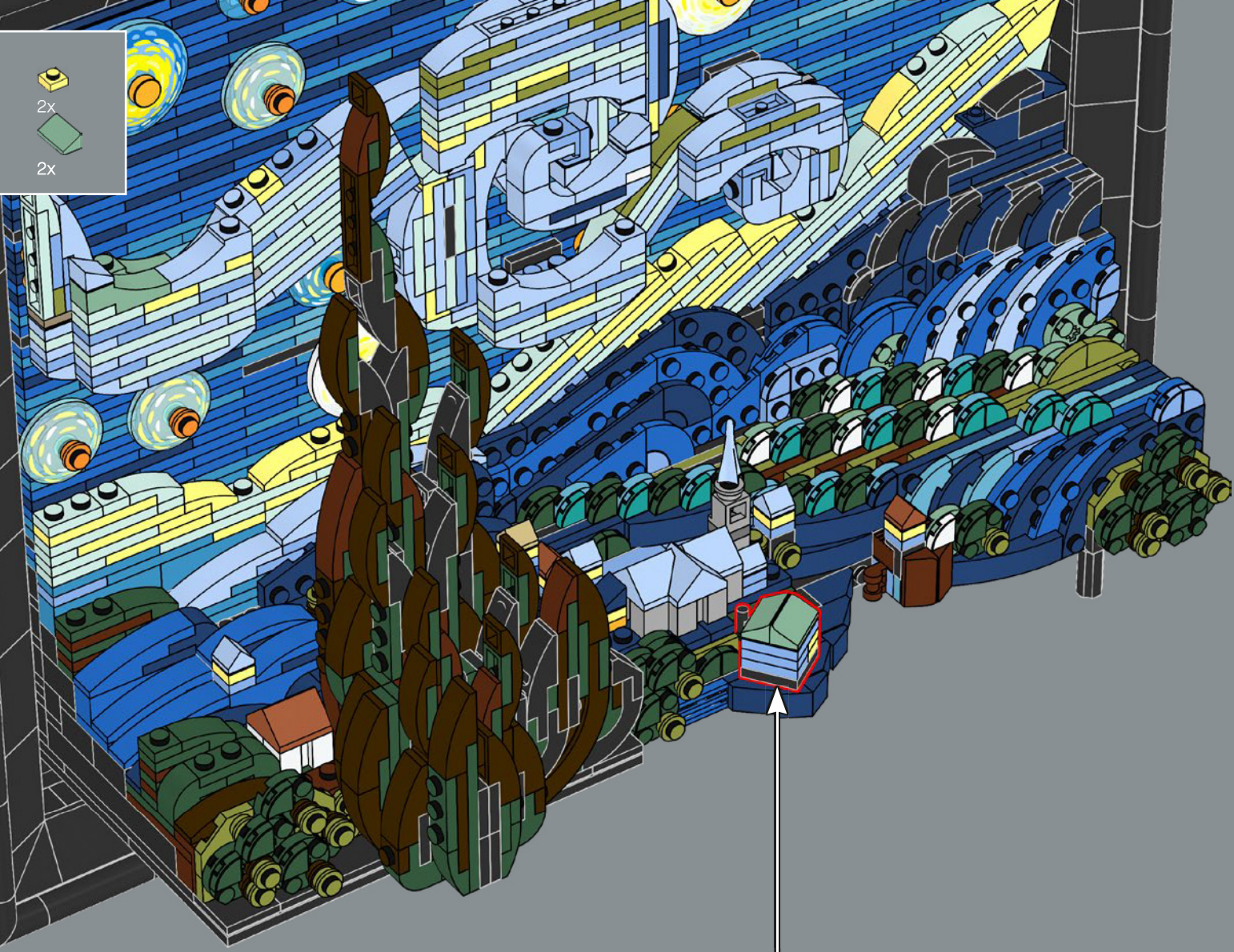

1	2	3	4	5

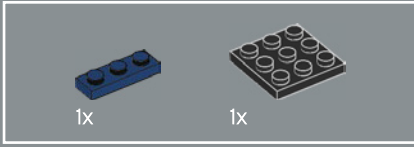
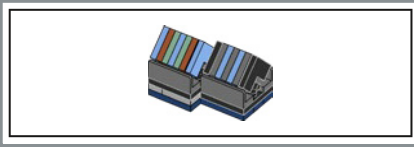

347

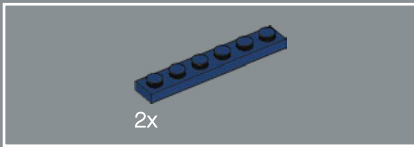
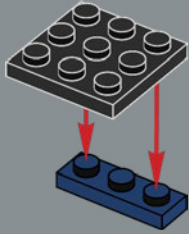

348

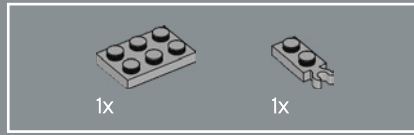
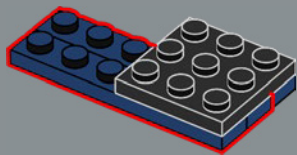

349

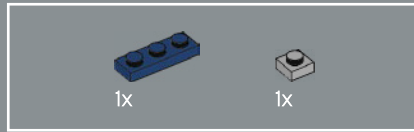
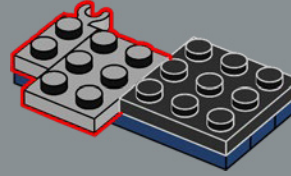

350

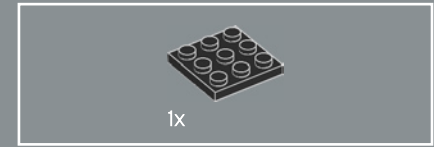
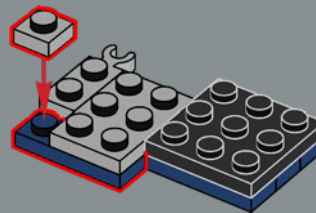

351

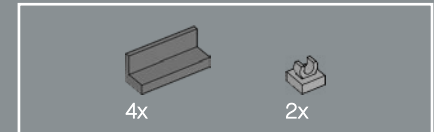
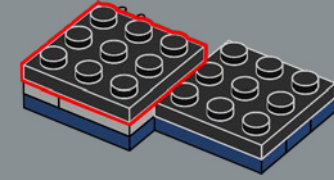

352

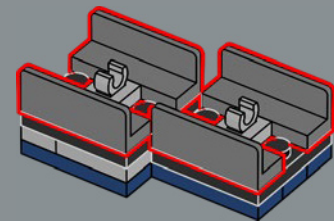

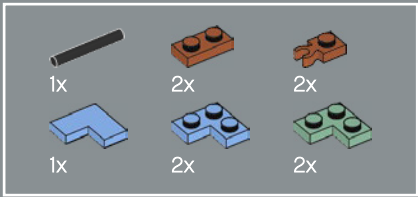

353

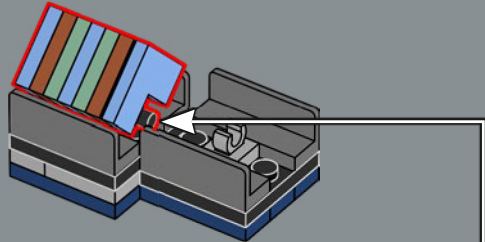

- 1
- 2
- 3
- 4
- 5

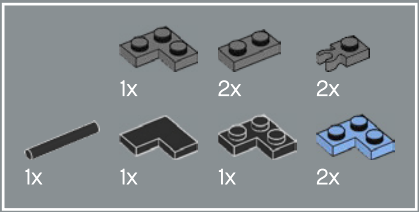

354

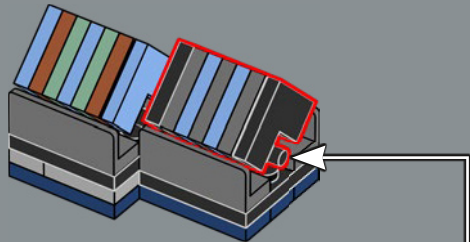

- 1
- 2
- 3
- 4
- 5

355

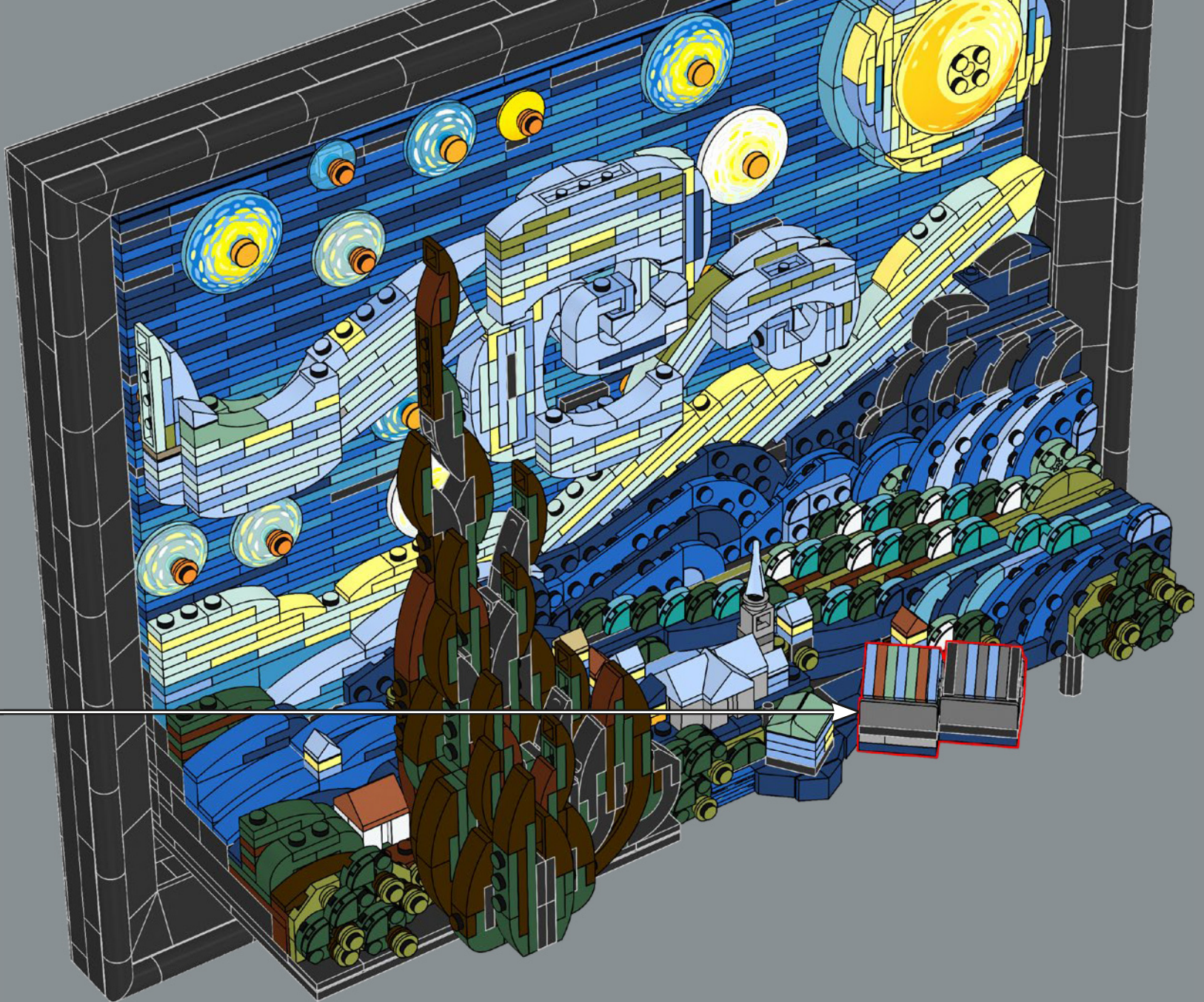

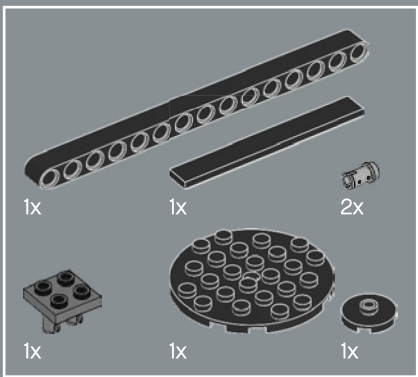

356

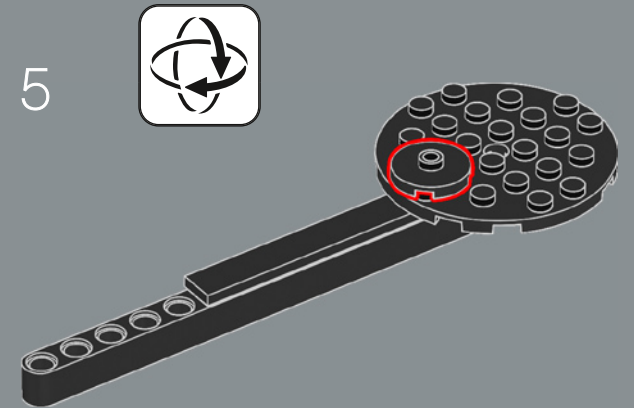
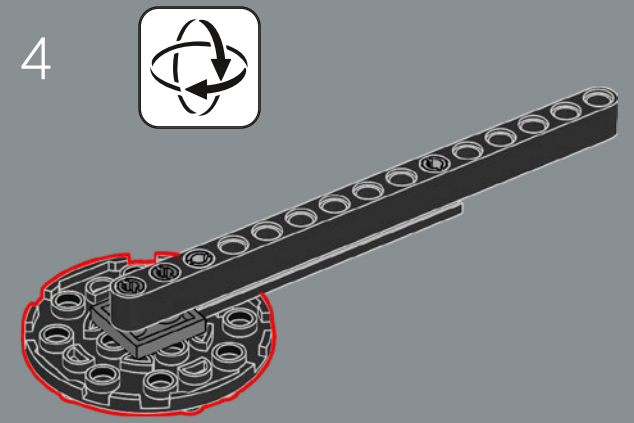
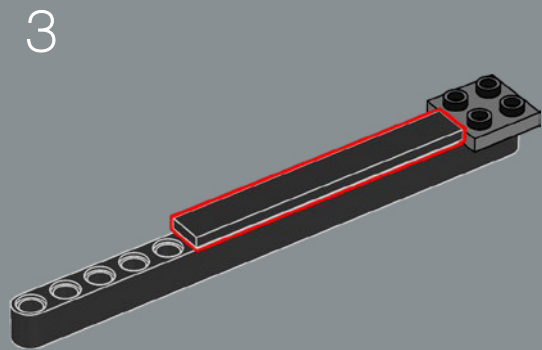
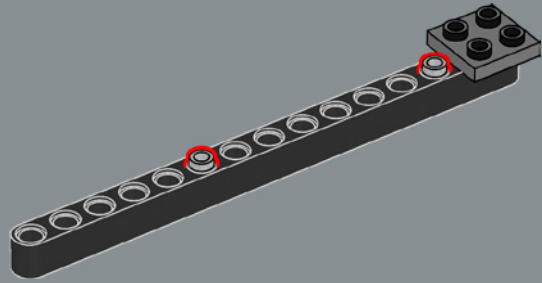
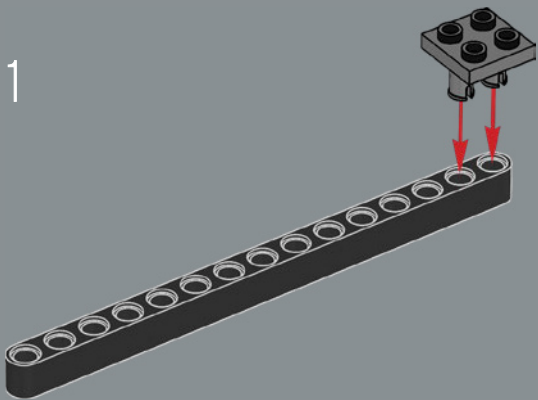

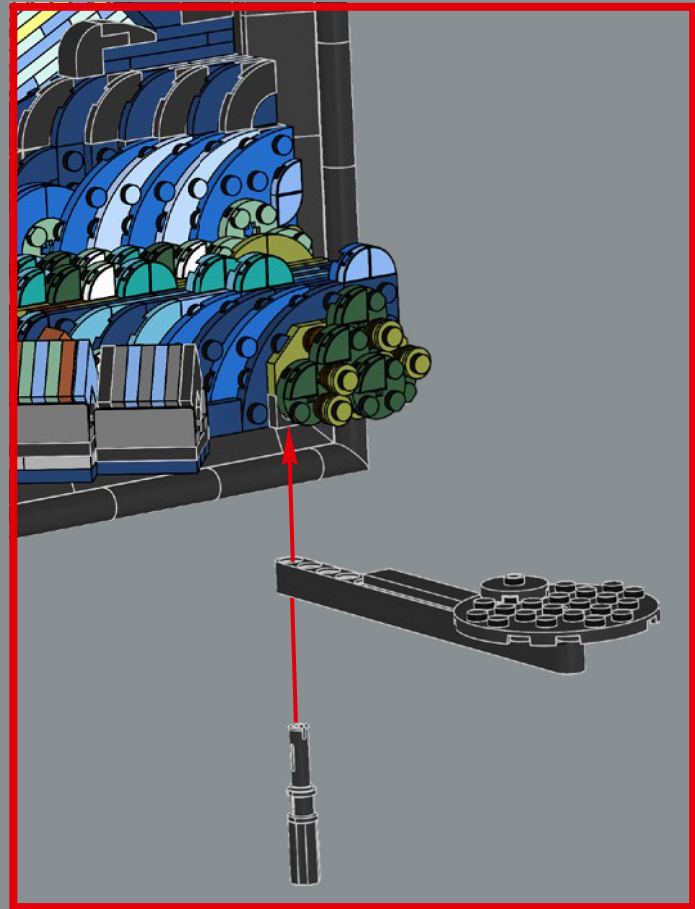
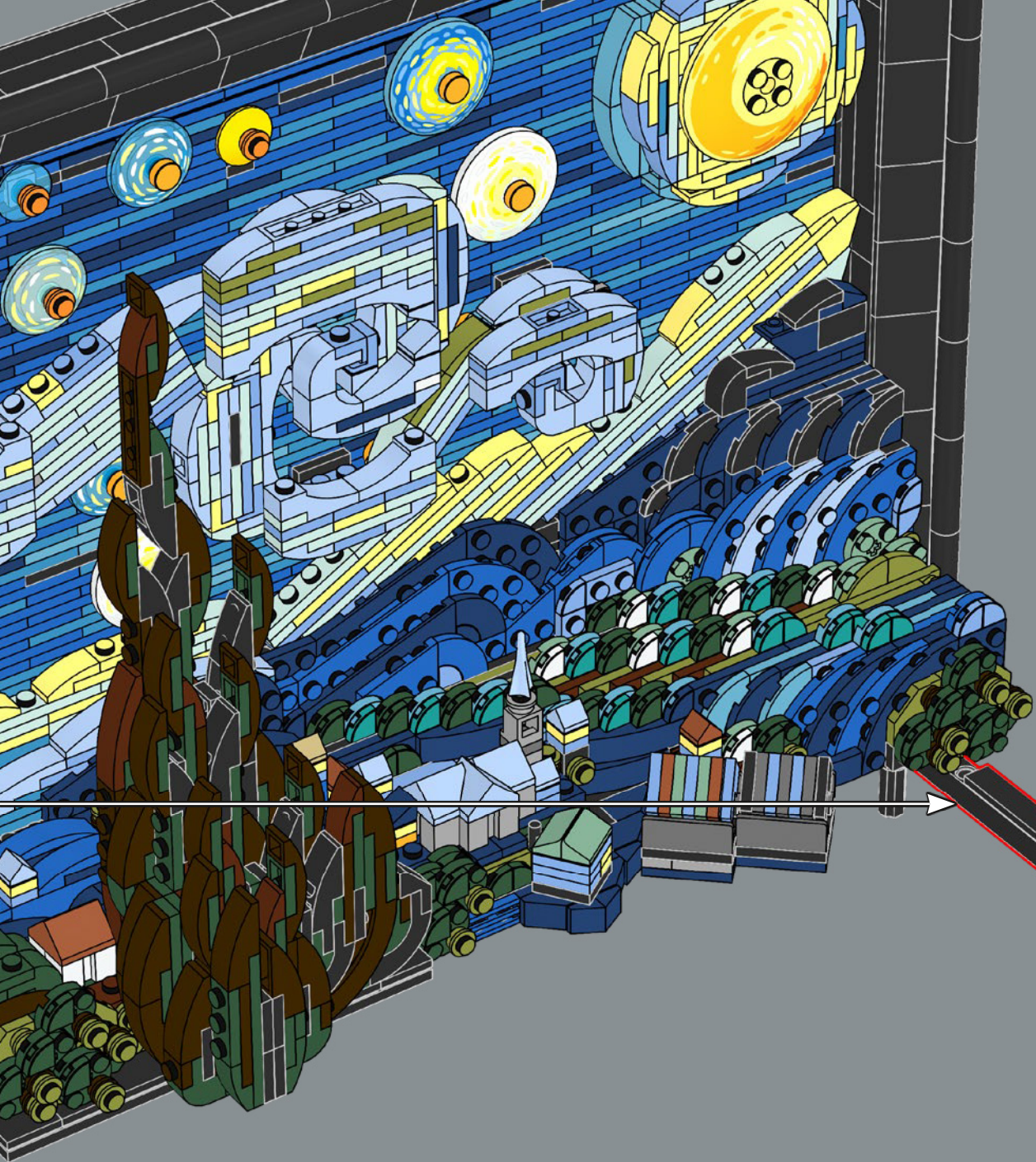





Toutes les œuvres sont de Vincent Van Gogh (Pays-Bas, 1853-1890).

Autoportrait au chapeau de feutre gris. Paris, 1886-1887. Huile sur carton, 41 cm x 32 cm. Amsterdam, Rijksmuseum

Portrait de Joseph Roulin. Arles, début 1889. Huile sur toile, 64,4 cm x 55,2 cm. Le Museum of Modern Art, New York. Don de M. et Mme William A. M. Burden, M. et Mme Paul Rosenberg, Nelson A. Rockefeller, M. et Mme Armand P. Bartos, la collection de Sidney et Harriet Janis, M. et Mme Werner E. Josten, et legs Loula D. Lasker (tous par échange).

Portrait du Dr Gachet (L'Homme à la pipe). 15 mai 1890. Eau-forte, plaque : 18,1 cm x 15,1 cm. Le Museum of Modern Art, New York. Don d'Abby Aldrich Rockefeller.

Les oliviers. Saint-Rémy, juin-juillet 1889. Huile sur toile, 72,6 cm x 91,4 cm. Le Museum of Modern Art, New York. Legs de Mme John Hay Whitney

Les mangeurs de pommes de terre. Avril 1885. Lithographie, composition : 21,5 cm x 31,4 cm; feuille : 31,3 cm x 40 cm. Éditeur : inédit. Imprimeur : Imprimerie Gestel, Nuenen. Tirage : 18 impressions connues. Le Museum of Modern Art, New York. Don de M. et Mme A. A. Rosen.

La nuit étoilée. Saint-Rémy, juin 1889. Huile sur toile, 73,7 cm x 92,1 cm. Le Museum of Modern Art, New York. Acquis grâce au legs Lillie P. Bliss (par échange)

Todas las obras de Vincent van Gogh (neerlandés, 1853-1890).

Auto retrato con sombrero de fieltro gris. París, 1886/87. Óleo sobre cartón, 41 x 32 cm. Museo Nacional de Amsterdam.

Retrato de Joseph Roulin. Arlés, principios de 1889. Óleo sobre lienzo, 64,4 x 55,2 cm. Museo de Arte Moderno, Nueva York (EE. UU.). Donación de William A. M. Burden y su esposa, Paul Rosenberg y su esposa, Nelson A. Rockefeller, Armand P. Bartos y su esposa, The Sidney and Harriet Janis Collection, Werner E. Josten y su esposa, y legado de Loula D. Lasker (todos por intercambio).

Retrato del Dr. Gachet ("Hombre con pipa"). 15 de mayo de 1890. Grabado, placa: 18,1 x 15,1 cm. Museo de Arte Moderno, Nueva York (EE. UU.). Donación de Abby Aldrich Rockefeller.

Los olivos. Saint Rémy, junio-julio de 1889. Óleo sobre lienzo, 72,6 x 91,4 cm. Museo de Arte Moderno, Nueva York (EE. UU.). Legado de la esposa de John Hay Whitney.

Los comedores de patatas. Abril de 1885. Litografía, composición: 21,5 x 31,4 cm; hoja: 31,3 x 40 cm. Editor: obra inédita. Impresor: Gestel Printing Works, Nuenen (Países Bajos). Edición: 18 impresiones confirmadas. Museo de Arte Moderno, Nueva York (EE. UU.). Donación de A. A. Rosen y su esposa.

La noche estrellada. Saint-Rémy, junio de 1889. Óleo sobre lienzo, 73,7 x 92,1 cm. Museo de Arte Moderno, Nueva York (EE. UU.). Adquirido mediante legado de Lillie P. Bliss (por intercambio).



IDEAS

SHARE YOUR IDEA
PARTAGE TON IDÉE
COMPARTE TU IDEA

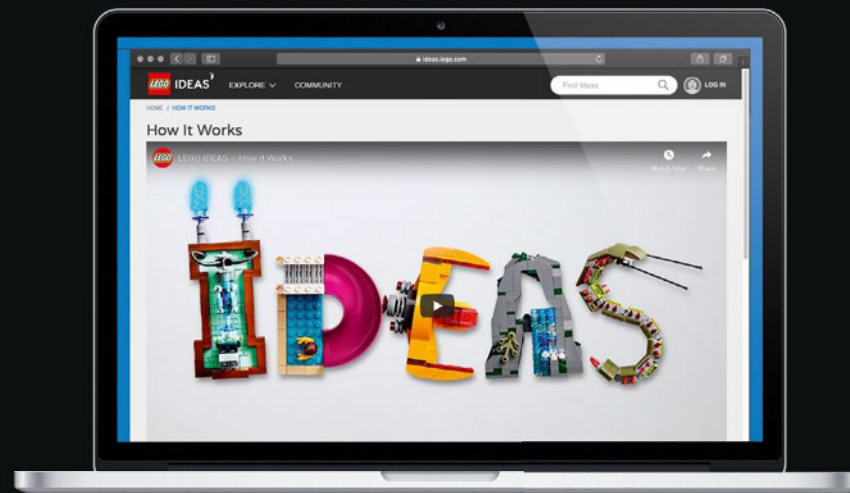
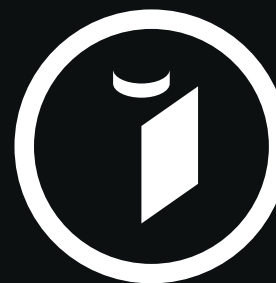

GATHER SUPPORT
OBTIENS DE L'APPUI
OBTÉN APOYOS



LEGO® REVIEW
EXAMEN LEGO®
REVISIÓN DE LEGO®



NEW LEGO® PRODUCT
NOUVEAU PRODUIT LEGO®
NUEVO PRODUCTO LEGO®



[Ideas.LEGO.com](https://ideas.lego.com)



© 20th Century Studios.

©SEGA. All rights reserved. SEGA is registered in the U.S. Patent and Trademark Office. SEGA and SONIC THE HEDGEHOG are either registered trademarks or trademarks of SEGA CORPORATION.

- 2x 4264360
- 1x 362301
- 1x 6397290
- 1x 6330191
- 1x 6046979
- 1x 4515364
- 7x 6172366
- 2x 6397305
- 1x 6230284
- 2x 6013938
- 3x 300121
- 1x 302021
- 1x 4142865
- 2x 301023
- 1x 300823
- 236
- 5x 4649773
- 3x 6045938
- 8x 302423
- 3x 302323
- 5x 241223
- 223x 371023
- 2x 302023
- 9x 366623
- 4x 416223
- 1x 303223
- 2x 4528850
- 14x 6117968
- 1x 6102539
- 2x 6189202
- 1x 4498155
- 3x 403223
- 1x 4543089
- 6x 6194724
- 2x 4581501
- 7x 6146306
- 1x 300324
- 1x 300224
- 2x 6310247
- 1x 370024
- 1x 6061025
- 1x 4169960
- 16x 300426
- 2x 362226
- 9x 300226
- 1x 301026
- 2x 300126
- 14x 300826
- 38x 6037390
- 2x 611126
- 1x 611226
- 29x 246526
- 1x 6170566
- 1x 6320309
- 1x 6275806
- 14x 4162443
- 4x 6039194
- 2x 654126
- 2x 370026
- 2x 6267487
- 1x 366526
- 2x 4121966
- 4x 6403373
- 76x 366026
- 3x 428626
- 4x 6144756
- 8x 416126
- 30x 329726
- 8x 6273589
- 2x 6047276
- 1x 6383142
- 8x 6370961
- 2x 4618880
- 68x 6370959
- 8x 6039869
- 2x 6112323
- 1x 6037664
- 1x 4542573
- 8x 6282140
- 1x 6302094
- 8x 302426
- 23x 302326
- 1x 302226
- 6x 306826
- 1x 6133722
- 1x 242026
- 2x 362326
- 4x 371026
- 3x 6174917
- 4x 302026
- 1x 4560182
- 1x 4243819
- 2x 379526
- 1x 416226

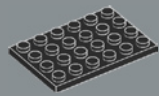

4x
303226

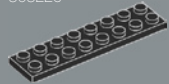

11x
303426

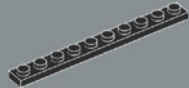

7x
447726

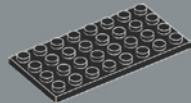

2x
303526

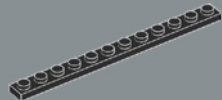

5x
4514845

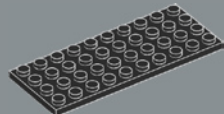

12x
303026

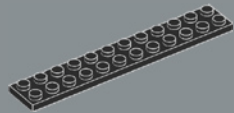

2x
244526

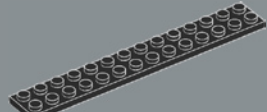

1x
6001494

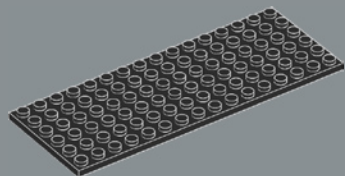

2x
302726



4x
6299338



1x
6157554



2x
6114987



4x
6000650



43x
6250020



2x
6013867



2x
6172383



1x
6195325



4x
6191630



1x
6187587

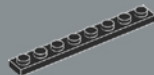

24x
346026



2x
6327028



1x
6371584



2x
6093525



1x
4598015



8x
6301857



2x
6000881



1x
6138662



1x
6031787



3x
6058245



11x
6016483



14x
6278088



1x
6279875



1x
4512363



1x
6321745



1x
6396678



4x
6361813



2x
6374150



1x
6340752



3x
4570877



2x
6340735



1x
6384432



3x
6397404



1x
6398233



2x
6397503



15x
4179826



52x
4179825



7x
4653540



1x
6167572



5x
6332365



5x
6170268



10x
4179828



2x
4179829



19x
6248079



6x
6332368



4x
6287382



5x
4157103



1x
6397185



1x
6240515



14x
6240467



2x
6055172



1x
6135607



4x
6031821



5x
4504374



1x
6097498



4x
6103405



3x
6115447



6x
4540280



4x
6042956



7x
4184108



49x
4528981



2x
6092588



1x
4528488



6x
6037890



5x
4177735



8x
4530028



60x
4502089

3,2

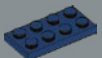

3x
4667595



2x
4508313



3x
4507080



5x
6199890



4x
6253881



6x
6199898



1x
6251836



3x
6023154



7x
4588024



9x
6055225



5x
6055169



38x
6013102



5x
6013975



4x
6253285

2x 6218162	13x 4245566	1x 4211242	6x 6117976	1x 4211476	2x 4211063	3x 6383091	1x 6384428	4x 4653970
1x 6306030	2x 6375006	1x 4223303	1x 6102975	1x 6335378	1x 4210635	12x 6392576	15x 6022199	8x 6035598
12x 6141593	2x 6375006	1x 4211149	1x 6361174	1x 6354568	1x 4211065	5x 6058766	11x 6135005	8x 6035598
23x 6058016	31x 6315608	2x 4211193	1x 6361174	1x 6354568	1x 4211065	26x 6184484	11x 6135005	5x 6119107
23x 6058016	29x 6035029	2x 6035291	2x 6215659	8x 4654580	1x 4257526	11x 6361988	1x 6266292	5x 6119107
42x 6146701	29x 6035029	2x 6035291	2x 6215659	4x 4654580	2x 6296892	2x 6383102	7x 6194729	38x 6070757
5x 6325961	2x 6210479	1x 4211197	2x 6075208	4x 6266231	2x 6296892	1x 6396057	1x 6266292	8x 6070757
35x 6141592	2x 6369375	10x 6172922	3x 6341968	4x 4654577	2x 6396058	1x 6284702	7x 6194729	38x 6070757
42x 6258990	2x 6369375	4x 6045941	6x 6341968	1x 6284702	1x 6284702	4x 6284702	12x 6252667	8x 4625036
4x 6278087	2x 6282619	1x 4211150	6x 6261744	1x 6168647	4x 6267047	1x 6070301	27x 6315780	8x 4625036
2x 6218089	13x 6223237	2x 4216695	1x 4211389	2x 4211483	9x 6115080	15x 6147726	18x 6058014	13x 6109752
5x 6278089	1x 6073040	13x 4211152	3x 4617170	2x 4211483	4x 6149768	26x 6201647	1x 6004943	2x 6258069
	15x 6322822	5x 4211204	1x 4211399	2x 6343854	7x 6372124	5x 6316265	2x 6004943	2x 6258069
		2x 4271874	3x 4617170	1x 6384433	4x 6149768	17x 6248756	2x 6213272	2x 6258069
			2x 4211396	1x 4211060	7x 6372124	6x 6236034	15x 4653988	2x 6397309
			1x 6258831	5x 4211104	4x 6228085	4x 6296497	4x 6151671	2x 6397309
			2x 6308012	2x 4210719	3x 6372136	1x 6397505	142x 6133728	1x 6397216

Customer Service
Kundenservice
Service Client
Assistenza clienti
Atención al cliente
Serviço de Apoio ao Consumidor
Ügyfélszolgálat
Klientu apkalpošanas dienests
Serviciul pentru client
客户服务
コンシューマーサービス
고객 서비스
LEGO.com/service



FEEDBACK AND WIN



FEEDBACK AND WIN

Your feedback will help shape the future development of this product series.

Please visit:

FEEDBACK UND GEWINNEN

Dein Feedback trägt zur Weiterentwicklung dieser Produktreihe bei.

Geh auf:

COMMENTEZ ET GAGNEZ

Vos commentaires nous aideront à concevoir les futurs produits de cette gamme.

Rendez-vous sur :

COMENTA Y GANA

Tu opinión nos ayudará a dar forma al desarrollo de esta serie de productos en el futuro.

Visita:

反馈有奖

您的反馈将有助于我们在今后改进本系列产品。

请访问：

[LEGO.com/productfeedback](https://www.lego.com/productfeedback)

By completing, you will automatically enter a drawing to win a LEGO® set.

Terms & Conditions apply.

Durch Ausfüllen nimmst du automatisch an der Verlosung eines LEGO® Preises teil.

Es gelten die Teilnahmebedingungen.

En envoyant vos commentaires, vous serez automatiquement inscrit(e) à un tirage au sort qui vous permettra de remporter un prix LEGO®.

Offre soumise à conditions.

Al contestar, participarás automáticamente en el sorteo y podrás ganar un set LEGO®.

Sujeto a Términos y Condiciones.

完成我们的反馈调查，即可自动进入抽奖环节，赢取乐高®套装。

适用《条款和条件》。

" It's clear that to
paint a starry sky it's
not nearly enough
to put white spots
on blue-black."

- Vincent van Gogh

« Il est évident que pour
peindre un ciel étoilé, il
ne suffise point du tout de
mettre des points blancs
sur du noir bleu. »

- Vincent van Gogh

" Es evidente que poner
puntos blancos sobre
negro azulado no es
suficiente para pintar
un cielo estrellado".

- Vincent van Gogh